

# Ballscrews

Technical Information

# HIWIN®

Motion Control and System Technology

High speed High precision

Multifunctional integration

Ecology first

Humanistic technology



TAIWAN EXCELLENCE  
GOLD AWARD 2005

### Ball screw

- For Heavy-Load Drive



TAIWAN EXCELLENCE  
2004

### Positioning Guideway

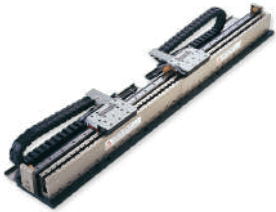

TAIWAN EXCELLENCE  
GOLD AWARD 2004

### Linear Synchronous Motor

- Coreless Type (LMC)
- Iron-core Type (LMS)



TAIWAN EXCELLENCE  
2002

### Linear Actuator

- LAN for Hospital
- LAM for Industrial
- LAS Compact Size
- LAK Controller



TAIWAN EXCELLENCE  
GOLD AWARD 2003

### Single Axis Robot

- For Semiconductor & Electronic (KK Robot)
- For Automation (KS, KA Robot)



TAIWAN EXCELLENCE  
SILVER AWARD 2009

### Linear Motor Air Bearing Platform

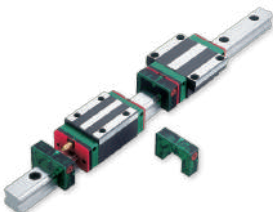

TAIWAN EXCELLENCE  
GOLD AWARD 2008  
TAIWAN EXCELLENCE  
SILVER AWARD 2007, 2002



### Linear Guideway

- HG/EG/RG/MG Type
- Self-Lubricating (E2)
- Low Noise (Q1)
- Air Jet (A1)

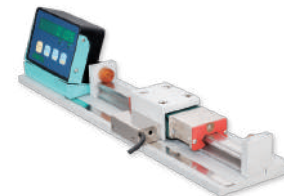

### Positioning Measurement System



TAIWAN EXCELLENCE  
GOLD AWARD 2009, 2008



TAIWAN EXCELLENCE  
SILVER AWARD 2006, 2001, 1993

### Ball screws

- Ground/Rolled
- High Speed (High Dm-N Value/Super S Series)
- Heavy Load (Cool type II)
- Self-Lubricating (E2)
- Rotating Nut (R1)



### Linear Motor X-Y Robot



TAIWAN EXCELLENCE  
SILVER AWARD 2006

### TMS Direct-Drive Positioning System



### Linear Motor Gantry

# HIWIN®

# Ballscrews

## Technical Information Index

<b>1. Introduction</b> .....	1
<b>2. Feature &amp; Application</b> .....	1
2.1 Features .....	1
2.2 Applications .....	4
<b>3. Classification of Standard Ballscrew</b> .....	5
3.1 Standard Ballscrew Spindle .....	5
3.2 Nut Configuration .....	5
3.3 Spindle End & Journal Configuration .....	7
<b>4. Design &amp; Selection of HIWIN Ballscrew</b> .....	9
4.1 Fundamental Concepts for Selection & Installation .....	9
4.2 Ballscrews Selection Procedure .....	12
4.3 Accuracy Grade of Ballscrews .....	12
4.4 Preload Methods .....	19
4.5 Calculation Formulas .....	21
4.6 Temperature Rise Effect on Ballscrews .....	34
<b>5. Specification Illustration</b> .....	36
<b>6. Precision Ground Ballscrews</b> .....	37
6.1 Ground Ballscrew Series .....	37
6.2 Dimension for Precision Ground Ballscrew .....	39
6.3 Miniature Ground Ballscrew .....	72
6.4 End Machining Ground Ballscrew Series .....	88
6.5 High Lead Ground Ballscrew .....	127
6.6 Ultra High Lead Ground Ballscrew .....	133
<b>7. Rolled Ballscrews</b> .....	136
7.1 Introduction .....	136
7.2 Precision Rolled Ballscrews .....	136
7.3 General Type of Rolled Ballscrews .....	138
7.4 Dimension for Rolled Ballscrews .....	139
7.5 Dimension for Stock Rolled Ballscrews .....	146
<b>8. Ballscrew Retrofit Kits for Manual Milling Machine</b> .....	150
<b>9. Multi-Solutions</b> .....	151

9.1 Super S Series .....	151
9.2 E2 Self-lubricant .....	156
9.3 R1 Rotating Nut .....	161
9.4 High Load Drive .....	162
9.5 Cool Type .....	163
<b>10. Supplement Information .....</b>	<b>167</b>
A. Ballscrew Failure Analysis .....	167
A1 Preface .....	167
A2 The Causes and Precautions of Ballscrew Problems .....	167
A3 Locating the Cause of Abnormal Backlash .....	170
B. Standard Housing Dimension Tolerance .....	171
C. Stand Spindle Dimension Tolerance .....	172
D. HIWIN Ballscrew Data Inquiry .....	173
E. HIWIN Ballscrew Request Form .....	174

(The specifications in this catalogue are subject to change without notification.)

# 1 Introduction

Ballscrews, also called a ball bearing screws, recirculating ballscrews, etc., consist of a screw spindle and a nut integrated with balls and the balls' return mechanism, return tubes or return caps. Ballscrews are the most common type of screws used in industrial machinery and precision machines. The primary function of a ballscrew is to convert rotary motion to linear motion or torque to thrust, and vice versa, with the features of high accuracy, reversibility and efficiency. HIWIN provides a wide range of ballscrews to satisfy your special requirements.

The combination of state-of-the-art machining technology, manufacturing experiences, and engineering expertise makes HIWIN ballscrew users "High-Tech Winners". HIWIN uses precise procedures to create exact groove profiles, either by grinding or precision rolling. Accurate heat treatment is also used to ensure the hardness of our ballscrews. These result in maximum load capacity and service life.

HIWIN precision ballscrews provide the most smooth and accurate movement, together with low drive torque, high stiffness and quiet motion with predictable lengthened service life. HIWIN rolled ballscrews also provide smooth movement and long life for general applications with less precision in lower price. HIWIN has modern facilities, highly skilled engineers, quality manufacturing and assembly processes, and uses quality materials to meet your special requirements.

It is our pleasure to provide you with the technical information and selection procedure to choose the right ballscrews for your applications through this catalogue.

# 2 Technological Features of HIWIN Ballscrews

## 2.1 Characteristics of HIWIN Ballscrews

There are many benefits in using HIWIN ballscrews, such as high efficiency and reversibility, backlash elimination, high stiffness, high lead accuracy, and many other advantages. Compared with the contact thread lead screws as shown in (Fig. 2.1), a ballscrew add balls between the nut and spindle. The sliding friction of the conventional screws is thus replaced by the rolling motion of the balls. The basic characteristics and resultant benefits of HIWIN ballscrews are listed in more details as follows:

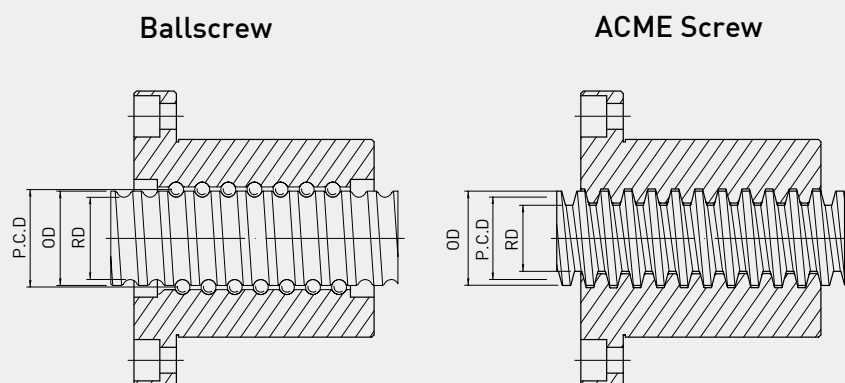

Fig 2.1 Basic configuration of ballscrews and contact thread lead screws

## (1) High efficiency and reversibility

Ballscrews can reach an efficiency as high as 90% because of the rolling contact between the screw and the nut. Therefore, the torque requirement is approximately one third of that of conventional screws. It can be seen from Fig. 2.2 that the mechanical efficiency of ball screws are much higher than conventional lead screws.

HIWIN ballscrews have super surface finish in the ball tracks which reduce the contact friction between the balls and the ball tracks. Through even contact and the rolling motion of the balls in the ball tracks, a low friction force is achieved and the efficiency of the ballscrew is increased. High efficiency renders low drive torque during ballscrew motion. Hence, less drive motor power is needed in operation resulting in lower operation cost.

HIWIN uses a series of test equipment and testing procedures to guarantee the efficiency.

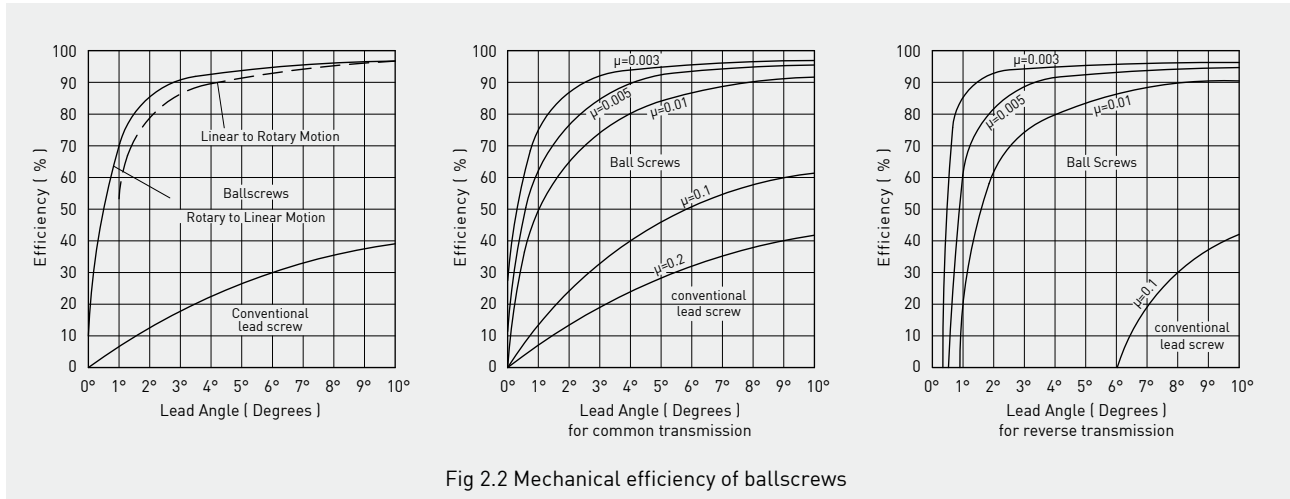

Fig 2.2 Mechanical efficiency of ballscrews

## (2) Backlash elimination and high stiffness

Computer Numerically Controlled (CNC) machine tools require ballscrews with zero axial backlash and minimal elastic deformation (high stiffness). Backlash is eliminated by our special designed Gothic arch form balltrack (Fig. 2.3) and preload.

In order to achieve high overall stiffness and repeatable positioning in CNC machines, preloading of the ballscrews is commonly used. However, excessive preload increases friction torque in operation. This induced friction torque will generate heat and reduce the life expectancy. With our special design and fabrication process, we provide optimized ballscrews with no backlash and less heat losses for your application.

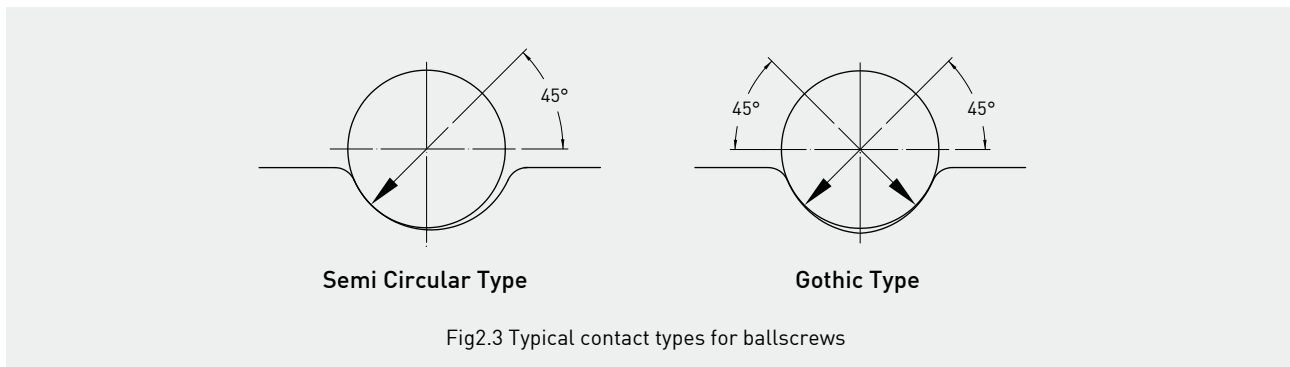

Fig2.3 Typical contact types for ballscrews

## (3) High lead accuracy

For applications where high accuracy is required, HIWIN modern facilities permit the achievement of ISO, JIS and DIN standards or specific customer requirements.

This accuracy is guaranteed by our precise laser measurement equipment and reported to each customer.

## (4) Predictable life expectancy

Unlike the useful life of conventional screws which is governed by the wear on the contact surfaces, HIWIN's ballscrews can usually be used till the metal fatigue. By careful attention to design, quality of materials, heat treatment and manufacture, HIWIN's ballscrews have proved to be reliable and trouble free during the period of expected service

life. The life achieved by any ballscrew depends upon several factors including design, quality, maintenance, and the major factor, dynamic axial load (C).

Profile accuracy, material characteristics and the surface hardness are the basic factors which influence the dynamic axial load.

It is recommended that the life at average axial load should be a minimum of  $1 \times 10^6$  revs). High quality ballscrews are designed to conform with the B rating (i.e. 90% probability of achieving the design life). Fifty percent of the ballscrews can exceed 2 to 4 times of the design life.

### (5) Low starting torque and smooth running

Due to metal to metal contact, conventional contact thread lead screws require high starting force to overcome the starting friction. However, due to rolling ball contact, ballscrews need only a small starting force to overcome their starting friction.

HIWIN uses a special design factor in the balltrack (conformance factor) and manufacturing technique to achieve a true balltrack. This guarantees the required motor torque to stay in the specified torque range.

HIWIN has special balltrack profile tracing equipment to check each balltrack profile during the manufacturing process. A sample trace is shown in Fig. 2.4.

HIWIN also uses computer measurement equipment to accurately measure the friction torque of ballscrews. A typical distance-torque diagram is shown in Fig. 2.5.

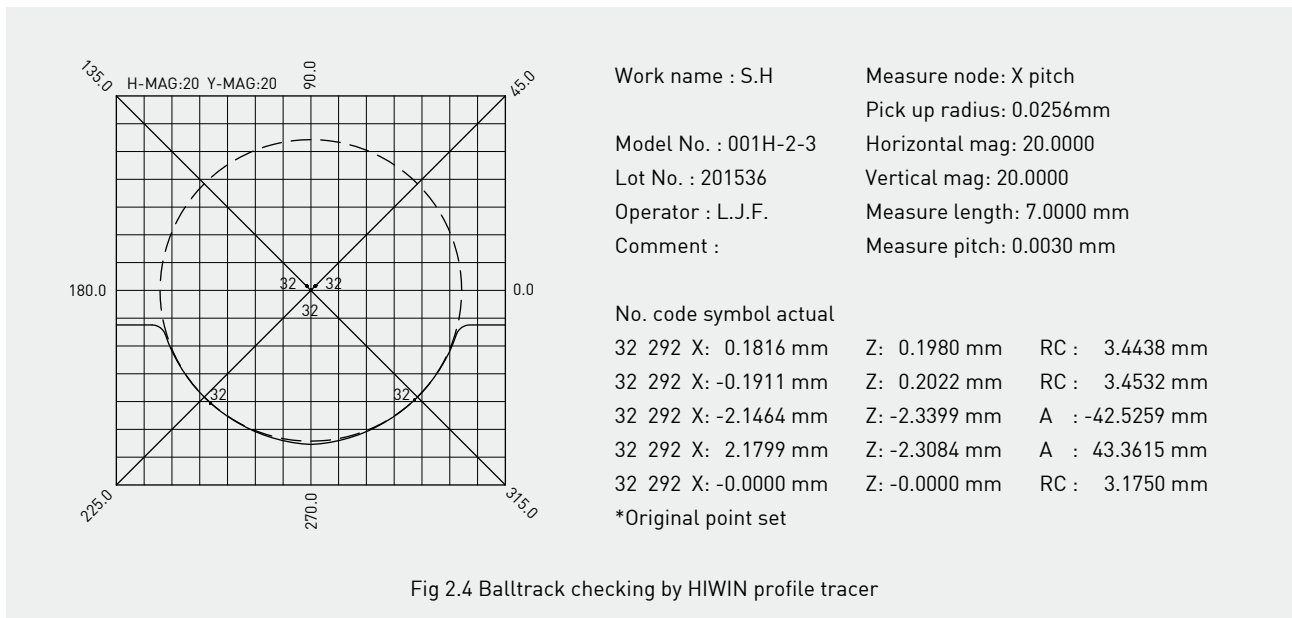

Fig 2.4 Balltrack checking by HIWIN profile tracer

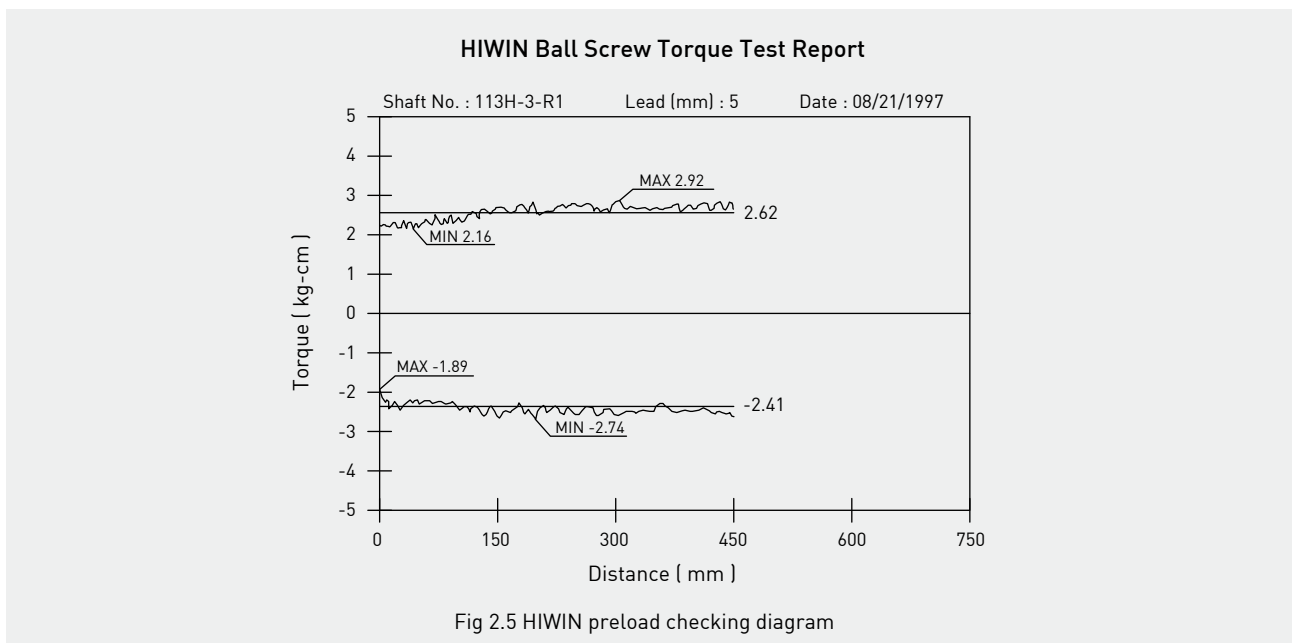

Fig 2.5 HIWIN preload checking diagram

## (6) Quietness

High quality machine tools require low noise during fast feeding and heavy load conditions.

HIWIN achieves this by virtue of its return system, balltrack designs, assembly technique, and careful control of surface finish and dimensions.

## (7) Short lead time

HIWIN has a fast production line and can stock ballscrews to meet short lead times.

## (8) Advantages over hydraulic and pneumatic actuators

The ballscrew used in an actuator to replace the traditional hydraulic or pneumatic actuator has many advantages, i.e. fast response, no leakage, no filtering, energy savings and good repeatability.

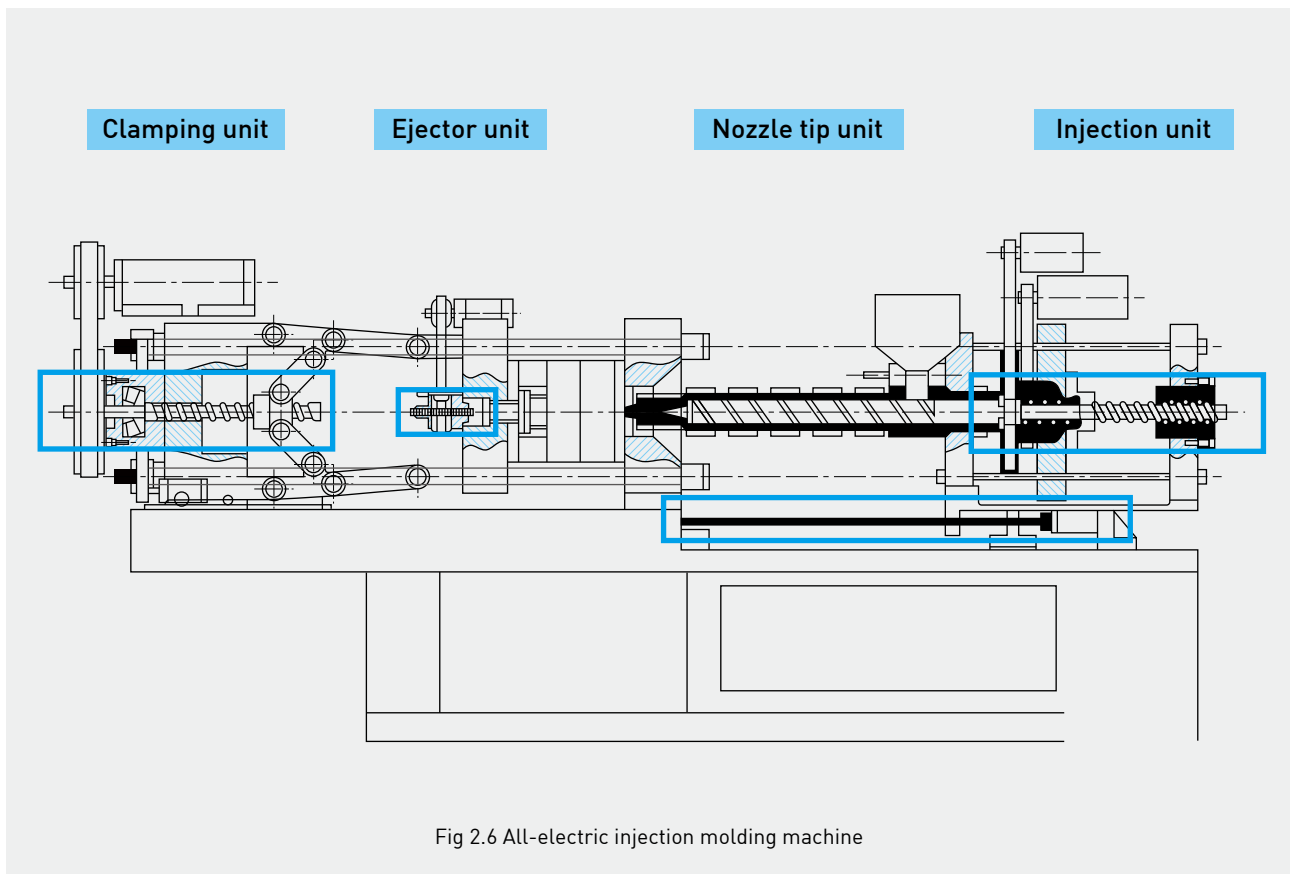

Fig 2.6 All-electric injection molding machine

## 2.2 Applications for Ballscrews

HIWIN ballscrews are used in the following fields and the recommended application grade can be found in Table 4.5.

1. **CNC machinery** : CNC machine center, CNC lathe, CNC milling machine, CNC EDM, CNC grinder, wire cutting machine, boring machine, etc.
2. **Precision machine tools** : Milling machine, grinder, EDM, tool grinder, gear manufacturing machine, drilling machine, planer, etc.
3. **Industrial machinery** : Printing machine, paper-processing machine, automatic machine, textile machine, drawing machine, special purpose machine, injection molding machine, etc.
4. **Electronic machinery** : Robot measuring instrument, X-Y table, medical equipment, surface mounting device, semi-conductor equipment, factory automation equipment, etc.
5. **Transport machinery** : Material handling equipment, elevated actuator, etc.
6. **Aerospace industry** : Aircraft flaps, thrust open-close reverser, airport loading equipment, fin actuator, etc.
7. **Miscellaneous** : Antenna leg actuator, valve operator, etc.



# 3 Classification of Standard Ballscrews

## 3.1 Standard Ballscrew Spindle

HIWIN recommends our standard regular ballscrews for your design. However, high lead, miniature or other special types of ballscrews, may also be available upon your request. Table 3.1 shows the standard ballscrew spindles which are available.

## 3.2 Nut Configuration

### (1) Type of return tube design

HIWIN ballscrews have three basic ball recirculation designs. The first, called the external recirculation type ballscrew, consists of the screw spindle, the ball nut, the steel balls, the return tubes and the fixing plate. The steel balls are introduced into the space between the screw spindle and the ball nut. The balls are diverted from the balltrack and carried back by the ball guide return tube form a loop. Since the return tubes are located outside the nut body, this type is called the external recirculation type ballscrew Fig. 3.1.

The second design, called the internal recirculation type ballscrew, consists of the screw spindle, the ball nut, the steel balls and the ball return caps. The balls make only one revolution around the screw spindle. The circuit is closed by a ball return cap in the nut allowing the balls to cross over adjacent ball tracks. Since the ball return caps are located inside the nut body, this is called the internal recirculation type ballscrew Fig. 3.2.

The third design is called endcap recirculation type ballscrew Fig.. 3.3.

The basic design of this return system is the same as the external recirculation type nut Fig. 3.4 except that the return tube is made inside the nut body as a through hole. The balls in this design traverse the whole circuit of the balltracks within the nut length. Therefore, a short nut with the same load capacity as the conventional design can be used.

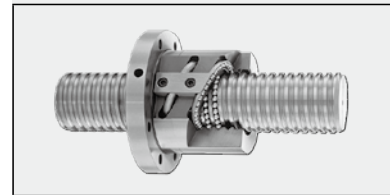

Fig3.1 External recirculation type nut with return tubes

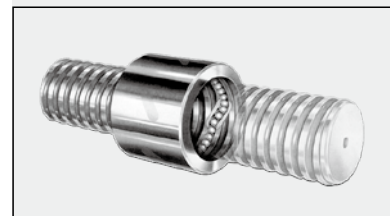

Fig3.2 Internal recirculation type nut with return caps

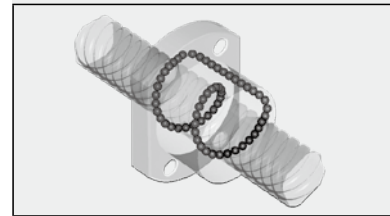

Fig3.3 Endcap recirculation type nut with return system

Table 3.1: HIWIN standard ballscrew spindle and lead

unit : mm

Type	Miniature					Regular								High lead				Super High Lead								
dia.	lead	1	1.5	2	2.5	3	3.175	4	4.23	5	5.08	6	6.35	8	10	12	12.7	16	20	24	25	25.4	32	40	50	
6	G	G	G																							
8	G	G	G	G										G												
10	G	G	G	G				G						G												
12		G	G	G				G	G					G												
15																			G							
16			G	G				G	G	G				G	G			G						G		
20			G	G				G	G	G	G			G	G			G	G						G	
22									G	G																
25				G				G	G	G	G	G	G	G			G	G	G			G				G
28									G	G	G	G	G	G												
32							G	G		G	G	G	G	G	G	G			G			G	G	G		
36									G		G			G	G	G										
40				G	G			G		G	G	G	G	G	G	G	G	G	G			G			G	G
45										G	G				G	G										
50									G	G	G	G	G	G	G	G	G		G			G			G	G
55														G	G	G	G									
63													G	G	G	G	G	G	G				G		G	G
70															G	G										
80															G	G	G	G	G							
100																G	G	G								

\*G : Precision ground grade ballscrews, either left-hand or right-hand screws are available.

## (2) Type of nuts

The type of nuts to select depends on the application requirements. HIWIN standard nuts are classified by three letters as follows (see also Chapter 5 for details):

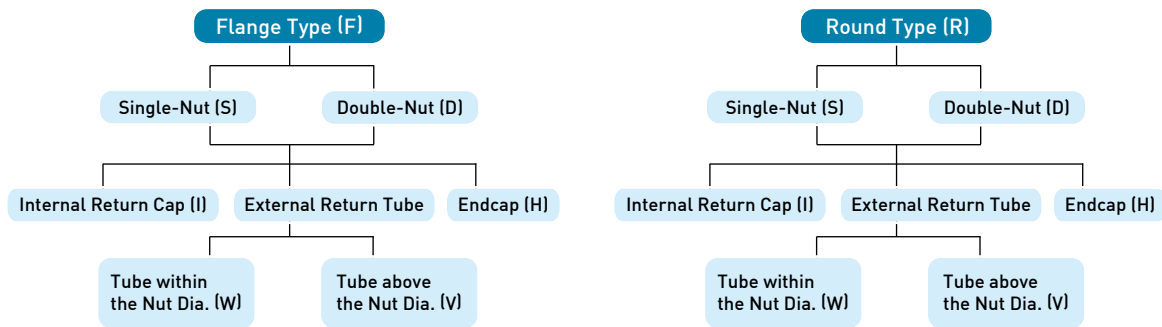

\* Other types of nut shape can also be made upon your design.

- The special high-lead double-start nut is classified by adding D in front of the above three letters.
- The compression preload nut is classified by adding P in front of the above three letters.
- The offset pitch preload single nut is classified by adding O in front of the above letters.

Examples :

**RDI** means round type, double nut with internal return caps.

**FSW** means flange type, single nut with external return tube within the nut diameter.

**DFSV** means two-start, flange, single nut with external return tube above the nut diameter.

## (3) Number of circuits

The HIWIN nomenclature for the number of circuits in the ballnut is described as follows:

**For the external type design:**

- A : 1.5 turns per circuit
- B : 2.5 turns per circuit
- C : 3.5 turns per circuit
- D : 4.5 turns per circuit
- E : 5.5 turns per circuit

**For the internal type design:**

- T : 1.0 turn per circuit

**For end cap type design:**

- U : 2.8 turns per circuit (high lead)
- S : 1.8 turns per circuit (super high lead)
- V : 0.8 turns per circuit (extra high lead)

**For Super S Series:**

- K : 1 turn per circuit

Example :

**B2** : designates 2 external return tube ball circuits. Each circuit has 2.5 turns.

**T3** : designates 3 internal return ball circuits. Each circuit has a maximum of 1 turn.

**S4** : designates 4 internal return ball circuits. Each circuit has 1.8 turns.

**K5** : designates 5 internal return ball circuits. Each circuit has 1 turn.

HIWIN recommends that number of circuits for the external type design be 2 for 2.5 or 3.5 turns ( that is, B2 or C2), and 3, 4 or 6 circuits for the internal type. Those shapes are shown in Fig. 3.4 and Fig. 3.5.

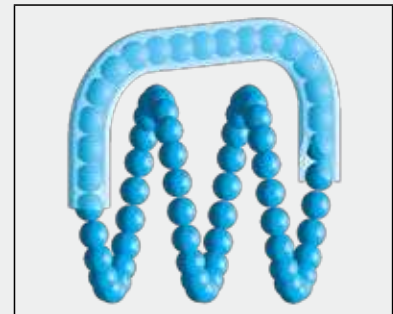

Fig 3.4 Circuit for external return tube



Fig 3.5 Circuit for internal return cap

### 3.3 Spindle End and Journal Configuration

#### Mounting methods

Bearing mounting methods on the end journals of ballscrews are crucial for stiffness, critical speed and column buckling load. Careful consideration is required when designing the mounting method. The basic mounting configuration are shown as follows Fig. 3.6.

#### Spindle end journal configurations

The most popular journal configurations are shown in Fig. 3.7.

Table 3.2 lists the recommended dimensions and the bearings for the configurations of Fig. 3.7.

Table 3.2 Dimension for spindle ends

Model	d1	d5	d6	d7	d8	E	L3	L4	L5	L6	L7	L8	L9	L10	L11	L12	L13	bxt1	Recommended Bearing	
																			I,II,III DIN625	III,IV,V DIN625 628 720
10	10	8	7.6	M8x0.75	6	6	16	7	29	26	0.9	39	50	56	18	10	12	3.0x1.8	608	738B
12	12	8	7.6	M8x0.75	6	6	16	7	29	26	0.9	39	50	56	18	10	12	3.0x1.8	608	738B
14	14	10	9.6	M10x0.75	8	8	20	9	37	34	1.15	45	54	62	20	10	14	3.0x1.8	6200	7200BTVP
16	16	12	11.5	M12x1	10	8	21	10	41	38	1.15	46	56	66	20	10	14	4.0x2.5	6201	7301BTVP
20	20	15	14.3	M15x1	12	-	22	11	47	44	1.15	55	70	84	25	13	16	5.0x3.0	6202	7202BTVP
25	25	17	16.2	M17x1	15	-	23	12	49	46	1.15	56	72	86	25	13	16	5.0x3.0	6203	7203BTVP
28	28	20	19	M20x1	16	-	26	14	58	54	1.35	68	82	100	28	20	18	6.0x3.5	6204	7602020TVP
32	32	25	23.9	M25x1.5	20	-	27	15	64	60	1.35	79	94	116	36	22	26	7.0x4.0	6205	7602025TVP
36	36	25	23.9	M25x1.5	20	-	27	15	64	60	1.35	79	94	116	36	22	26	7.0x4.0	6205	7602025TVP
40	40	30	28.6	M30x1.5	25	-	28	16	68	64	1.65	86	102	126	42	22	32	8.0x4.0	6206	7602030TVP
45	45	35	33.3	M35x1.5	30	-	29	17	80	76	1.65	97	114	148	50	24	40	10.0x5.0	6207	7602035TVP
50	50	40	38	M40x1.5	35	-	36	23	93	88	1.95	113	126	160	60	24	45	12.0x5.0	6308	7602040TVP
55	55	45	42.5	M45x1.5	40	-	38	25	93	88	1.95	125	138	168	70	24	50	14.0x5.5	6309	7602045TVP
63	63	50	47	M50x1.5	45	-	33	27	102	97	2.2	140	153	188	80	27	60	14.0x5.5	6310	7602050TVP
70	70	55	52	M55x2.0	50	10	44	29	118	113	2.2	154	167	212	90	27	70	16.0x6.0	6311	7602055TVP
80	80	65	62	M65x2.0	60	10	49	33	132	126	2.7	171	184	234	100	30	80	18.0x7.0	6313	7602065TVP
100	100	75	72	M75x2.0	70	10	53	37	140	134	2.7	195	208	258	120	30	90	20.0x7.5	6315	7602075TVP

\* We reserve the right to modify and improve data value without prior notice.

\* Different diameters and leads are available upon request.

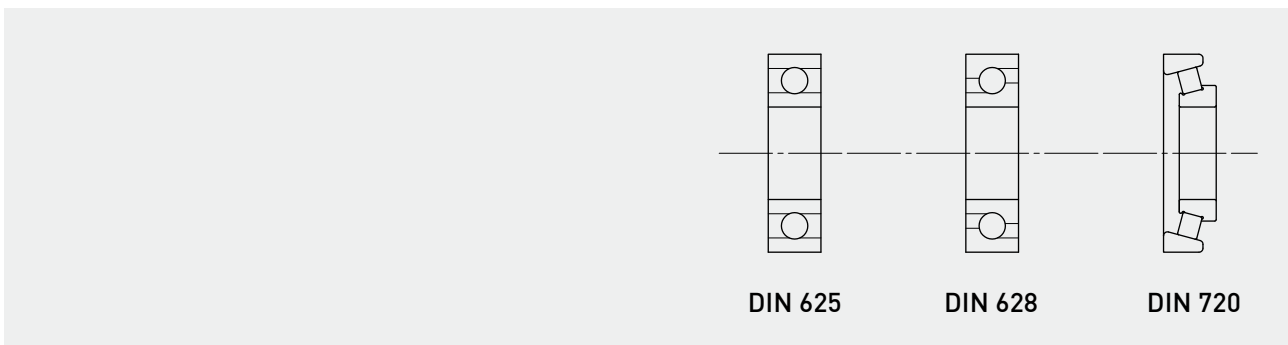

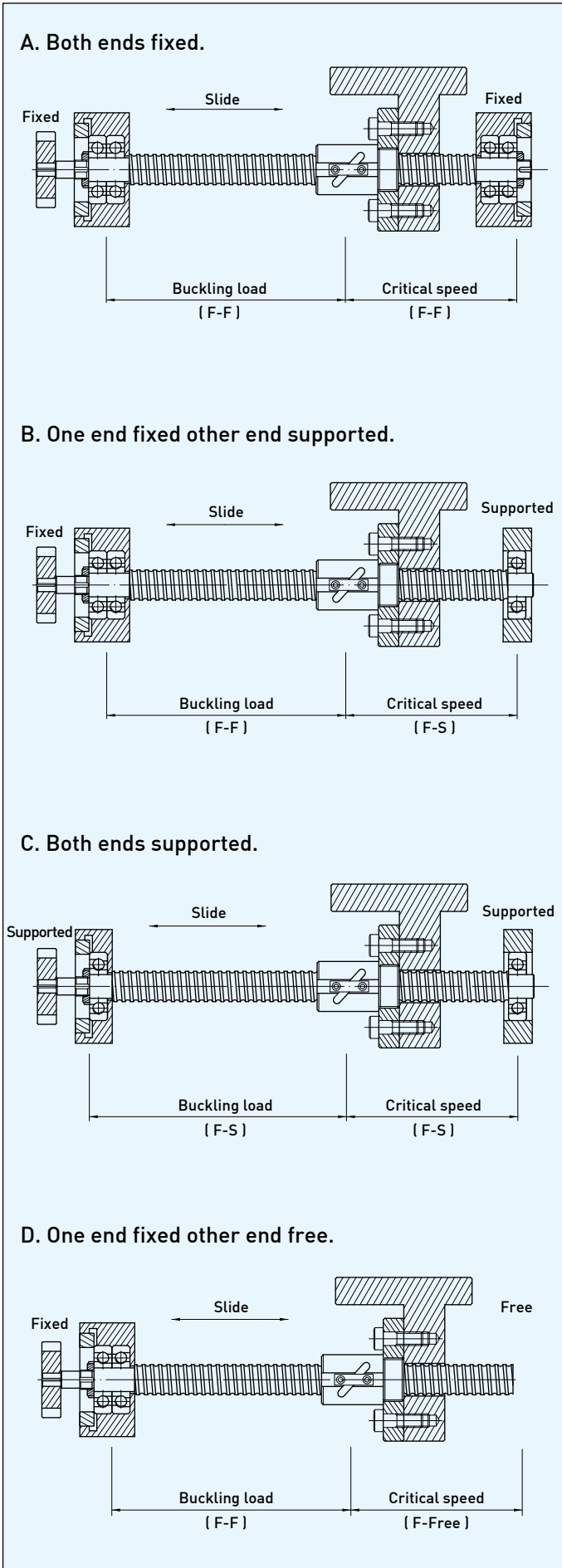

Fig 3.6 Recommended mounting methods for the ballscrew end journals

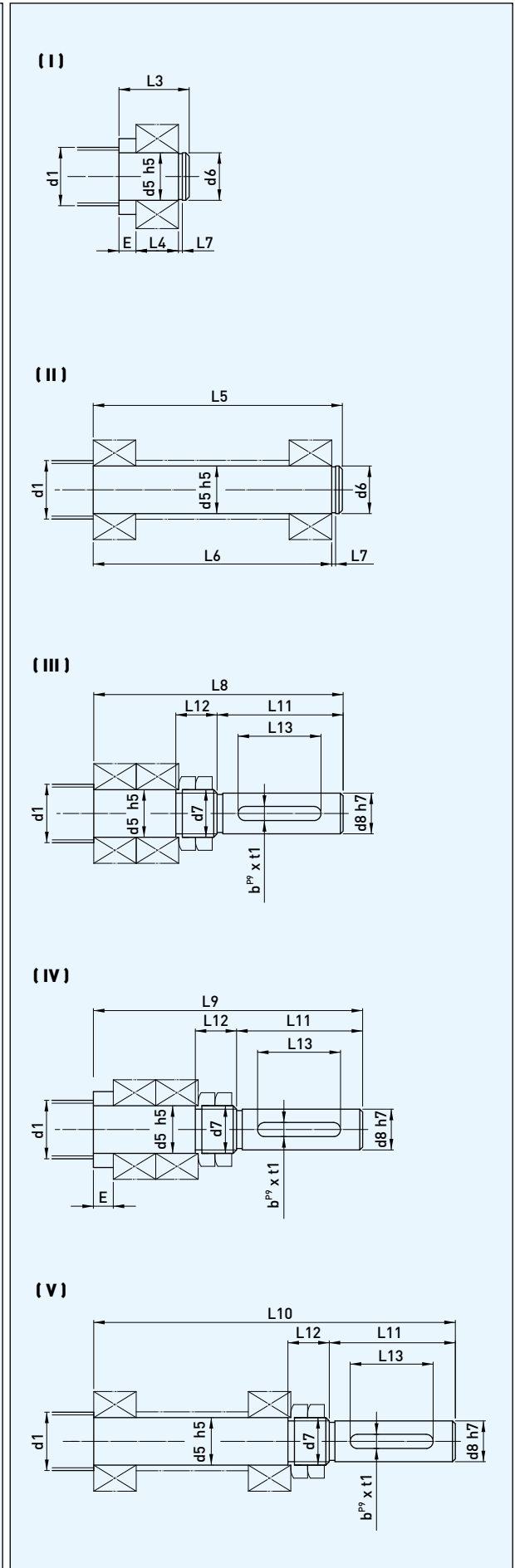

Fig 3.7 Configurations of spindle ends

# 4 Design and Selection of HIWIN Ballscrews

## 4.1 Fundamental Concepts for Selection & Installation

- (1) A ballscrew must be thoroughly cleaned in white spirit and oil to protect against corrosion. Trichloroethylene is an acceptable degreasing agent, ensuring the ball track free from dirt and damage (paraffin is not satisfactory). Great care must be taken to ensure that the ball track is not struck by a sharp edged component or tool, and metallic debris does not enter the ball nut (Fig. 4.1).
- (2) Select a suitable grade ballscrew for the application (ref. Table 4.5). Install with corresponding mounting disciplines. That is, precision ground ballscrews for CNC machine tools demand accurate alignment and precision bearing arrangement, where the rolled ballscrews for less precision applications, such as packaging machinery, require less precise support bearing arrangement.

It is especially important to eliminate misalignment between the bearing housing center and the ballnut center, which would result in unbalanced loads (Fig. 4.2). Unbalanced loads include radial loads and moment loads (Fig. 4.2a). These can cause malfunction and reduce service life (Fig.4.2b).

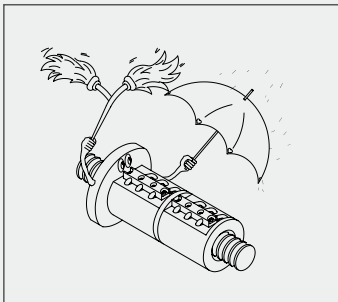

Fig 4.1 Carefully clean and protect

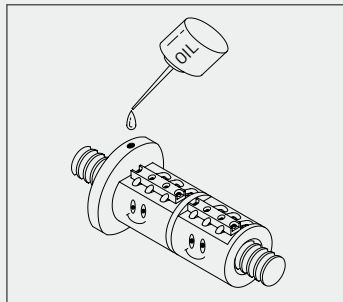

Fig 4.2 Oil lubrication method.

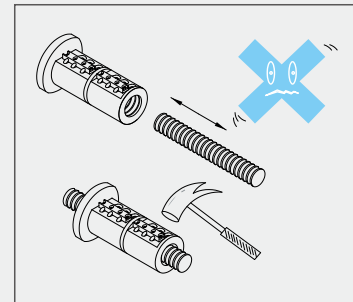

Fig 4.3 Carefully protect the nut

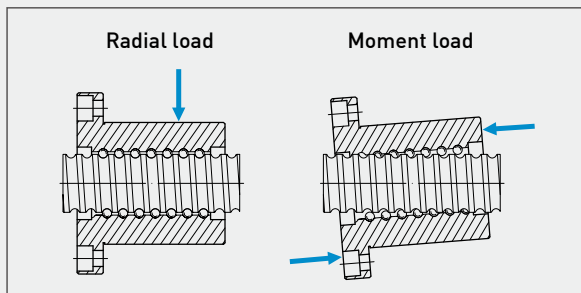

Fig 4.2(a) Unbalance load caused by misalignment of the support bearings and nut brackets, inaccurate alignment of the guide surface, inaccurate angle or alignment of the nut mounting surface

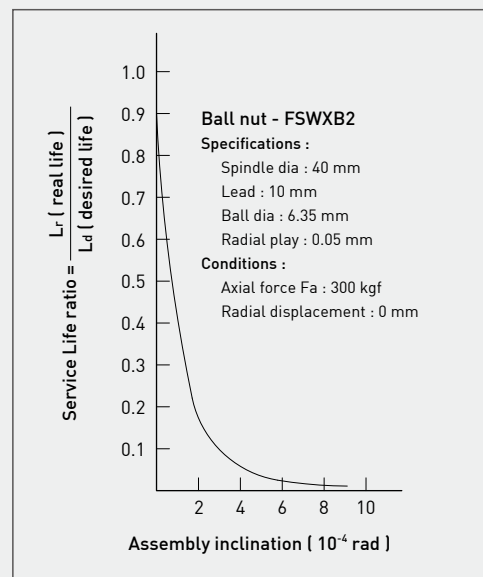

Fig 4.2(b) The effect on service life of a radial load caused by misalignment

- (3) To achieve the ballscrews' maximum life, recommend the use of antifriction bearing oils. Oil with graphite and  $\text{MoS}_2$  additives must not be used. The oil should be maintained over the balls and the balltracks.
- (4) Oil mist bath or drip feeds are acceptable. However, direct application to the ball nut is recommended (Fig. 4.3).
- (5) Select a suitable support bearing arrangement for the screw spindle. Angular contact ball bearings (angle=60°) are recommended for CNC machinery. Because of higher axial load capacity and ability to provide a clearance-free or preloaded assembly (Fig. 4.4).

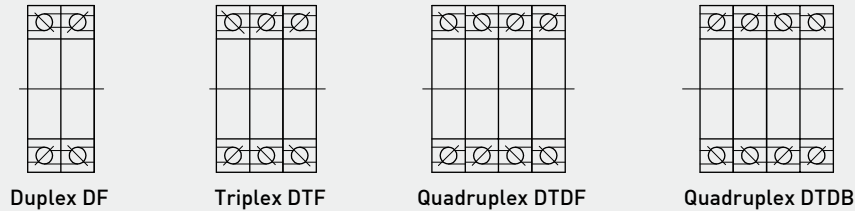

Fig 4.4 Different arrangement of ballscrew support bearings

- (6) A dog stopper should be installed at the end to prevent the nut from over-travelling which results in damage to ballscrew assembly (Fig 4.5).
- (7) In environments contaminated by dust or metallic debris, ballscrews should be protected using telescopic or bellow-type covers. The service life of a ballscrew will be reduced to about one-tenth normal condition if debris or chips enter the nut. The bellow type covers may need to have a threaded hole in the flange to fix the cover. Please contact engineers when special modifications are needed (Fig 4.6).

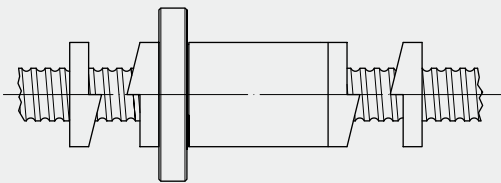

Fig 4.5 A dog stopper to prevent the nut from over travelling

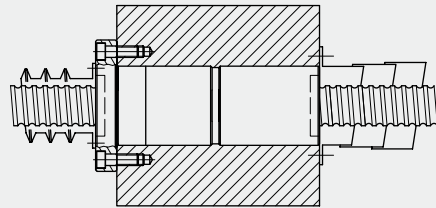

Fig 4.6 Ballscrew protection by telescopic or bellow type covers

- (8) If you select an internal recirculation type or an endcap recirculation type ballscrew, one end of the ball thread must be cut through to the end surface. The adjacent diameter on the end journal must be 0.5 ~ 1.0 mm less than the root diameter of the balltracks (Fig 4.7).
- (9) After heat treating the ballscrew spindle, both ends of the balltracks adjacent to the journal have about 2 to 3 leads left soft, for the purpose of machining. These regions are shown in (Fig. 4.8) with the mark "●" on HIWIN drawings.

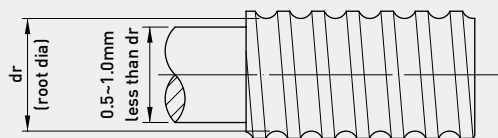

Fig 4.7 Special arrangement for the end journal of an internal recirculation screw

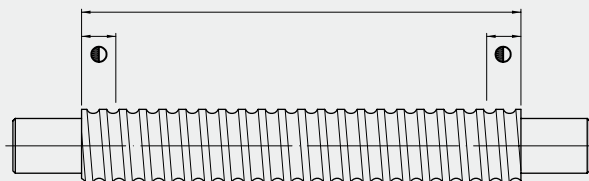

Fig 4.8 The heat treatment range of the ballscrew spindle

- (10) Excessive preload increases the friction torque and generates heat which reduces the life expectancy. But insufficient preload reduces stiffness and increases the possibility of lost motion. Recommends that the maximum preload used for CNC machine tools should not exceed 8% of the basic dynamic load C.
- (11) When the nut needs to be disassembled from/assembled to the screw spindle, a tube with an outer dia. 0.2 to 0.4 mm less than the root diameter (ref. M37) of the balltracks should be used to release/connect the nut to from/to the screw spindle via one end of the screw spindle shown in Fig. 4.9.
- (12) As shown in Fig 4.10, the support bearing must have a chamfer to allow it to seat properly and maintain proper alignment. HIWIN suggests the DIN 509 chamfer as the standard construction for this design (Fig. 4.11).

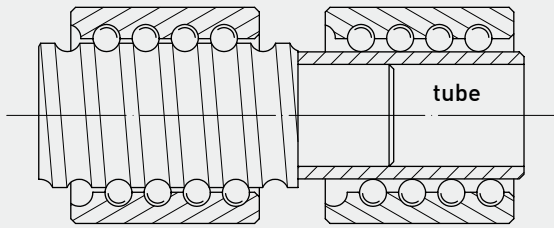

Fig 4.9 The method of separating the nut from the screw spindle

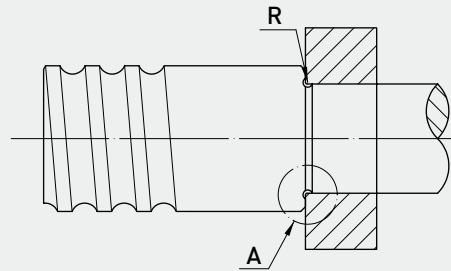

Fig 4.10 Chamfer for seating the face of bearing end spindle

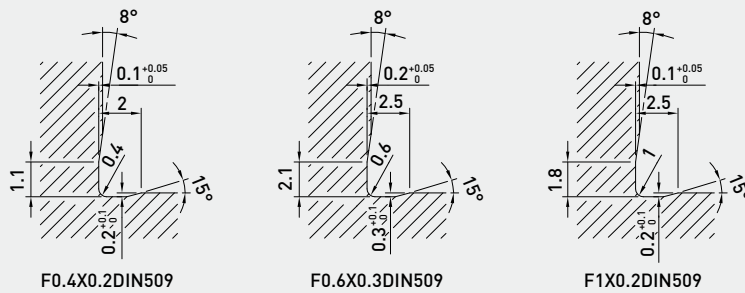

Fig 4.11 Suggested chamfer dimension per DIN 509 for the "A" dimension in Fig 4.10

## 4.2 Ballscrews Selection Procedure

The selection procedure for ballscrews is shown in (Table 4.1) From the known design operation condition, (A) select the appropriate parameter of ballscrew, (B) follow the selection procedure step by step via the reference formula, and (C) find the best ballscrew parameters which can be met for the design requirements.

Table 4.1 Ballscrew selection procedure

Step	Design operation condition (A)	Ballscrew parameter (B)	Reference formula(C)
Step 1	Positioning accuracy	Lead accuracy	Table 4.2
Step 2	(1) Max. speed of DC motor (Nmax) (2) Rapid feed rate (Vmax)	Ballscrew lead	$\ell \geq \frac{V_{\max}}{N_{\max}}$
Step 3	Total travel distance	Total thread length	Total length = thread length+journal end length Thread length = stroke+nut length+100 mm (unused thread)
Step 4	(1) Load condition (%) (2) Speed condition (%)	Mean axial load Mean speed	M7~M10
Step 5	Mean axial force ( $\leq 1/5 C$ is the best)	Preload	M1
Step 6	(1) Service life expectancy (2) Mean axial load (3) Mean speed	Basic dynamic load	M13~M14
Step 7	(1) Basic dynamic load (2) Ballscrew lead (3) Critical speed (4) Speed limited by Dm-N value	Screw diameter and nut type (select some range)	M31~M33 and dimension table
Step 8	(1) Ballscrew diameter (2) Nut type (3) Preload (4) Dynamic load	Stiffness (check the best one via lost motion value)	M34~M40
Step 9	(1) Surrounding temperature (2) Ballscrew length	Thermal displacement and target value of cumulative lead (T)	M41 and 4.6 temperature rising effect
Step 10	(1) Stiffness of screw spindle (2) Thermal displacement	Pretension force	M45
Step 11	(1) Max. table speed (2) Max. rising time (3) Ballscrew specification	Motor drive torque and motor specification	M19~M28

## 4.3 Accuracy Grade of HIWIN Ballscrews

Precision ground ballscrews are used in applications requiring high positioning accuracy and repeatability, smooth movement and long service life. Ordinary rolled ballscrews are used for application grade less accurate but still requiring high efficiency and long service life. Precision grade rolled ballscrews have an accuracy between that of the ordinary grade rolled ballscrews and the higher grade precision ground ballscrews. They can be used to replace certain precision ground ballscrews with the same grade in many applications.

HIWIN makes precision grade rolled ballscrew up to C6 grade. Geometric tolerances are different from those of precision ground screws (See Chapter 6). Since the outside diameter of the screw spindle is not ground, the set-up procedure for assembling precision rolled ballscrews into the machine is different from that of ground ones. Chapter 7 contains the entire description of rolled ballscrews.

### (1) Accuracy grade

There are numerous applications for ballscrews from high precision grade ballscrews, used in precision measurement and aerospace equipment, to transport grade ballscrews used in packaging equipment. The quality and accuracy classifications are described as follows: lead deviation, surface roughness, geometrical tolerance, backlash, drag torque variation, heat generation and noise level.



HIWIN precision ground ballscrews are classified to 7 classes. In general, HIWIN precision grade ballscrews are defined by the so called “ $v_{300p}$ ” value see Fig 4.12 and rolled grade ballscrews are defined differently as shown in Chapter 7.

Fig. 4.12 is the lead measuring chart according to the accuracy grade of the ballscrews. The same chart by the DIN system is illustrated in Fig. 4.13. From this diagram, the accuracy grade can be determined by selecting the suitable tolerance in Table 4.2. Fig. 4.14 shows HIWIN’s measurement result according to the DIN standard. Table 4.2 shows the accuracy grade of precision grade ballscrews in HIWIN’s specification. The relative international standard is shown in Table 4.3.

The positioning accuracy of machine tools is selected by  $e_p$  value with the  $v_{300p}$  variation. The recommended accuracy grade for machine applications is shown in Table 4.5. This is the reference chart for selecting the suitable ballscrews in different application fields.

## (2) Axial play (Backlash)

If zero axial play ballscrews (no backlash) are needed, preload should be added and the preload drag torque is specified for testing purpose. The standard axial play of HIWIN ballscrews is shown in Table 4.4. For CNC machine tools, lost motion can occur in zero-backlash ballscrews through incorrect stiffness. Please consult our engineers when determining stiffness and backlash requirements.

## (3) Geometrical tolerance

It is crucial to select the ballscrew of the correct grade to meet machinery requirements. Table 4.6 and Fig 4.15 are helpful for you to determine the tolerance factors, which are based on certain required accuracy grades.

Table 4.2 HIWIN accuracy grade of precision ballscrew

Unit: 0.001mm

Accuracy Grade		C0		C1		C2		C3		C4		C5		C6			
$v_{2p}$		3		4		4		6		8		8		8			
$v_{30p}$		3.5		5		6		8		12		18		23			
Thread length Item		$e_p$		$v_u$		$e_p$		$v_u$		$e_p$		$v_u$		$e_p$		$v_u$	
		above	below														
-	315	4	3.5	6	5	6	6	12	8	12	12	23	18	23	23		
315	400	5	3.5	7	5	7	6	13	10	13	12	25	20	25	25		
400	500	6	4	8	5	8	7	15	10	15	13	27	20	27	26		
500	630	6	4	9	6	9	7	16	12	16	14	30	23	30	29		
630	800	7	5	10	7	10	8	18	13	18	16	35	25	35	31		
800	1000	8	6	11	8	11	9	21	15	21	17	40	27	40	35		
1000	1250	9	6	13	9	13	10	24	16	24	19	46	30	46	39		
1250	1600	11	7	15	10	15	11	29	18	29	22	54	35	54	44		
1600	2000			18	11	18	13	35	21	35	25	65	40	65	51		
2000	2500			22	13	22	15	41	24	41	29	77	46	77	59		
2500	3150			26	15	26	17	50	29	50	34	93	54	93	69		
3150	4000			30	18	32	21	60	35	62	41	115	65	115	82		
4000	5000							72	41	76	49	140	77	140	99		
5000	6300							90	50	100	60	170	93	170	119		
6300	8000							110	60	125	75	210	115	210	130		
8000	10000											260	140	260	145		
10000	12000											320	170	320	180		

Table 4.3 International standard of accuracy grade for ballscrews

Unit: 0.001mm

Grade		Ground										
							Rolled					
		C0	C1	C2	C3	C4	C5	C6	C7	C8	C10	
$v_{300p}$	ISO, DIN		6		12		23			52		210
	JIS	3.5	5		8		18			50		210
	HIWIN	3.5	5	6	8	12	18	23	50	100	210	

Table 4.4 Standard combination of grade and axial play

Unit: 0.001mm

Grade	C0	C1	C2	C3	C4	C5	C6
Axial Play	5	5	5	10	15	20	25

Table 4.5 Recommended accuracy grade for machine applications

Application grade		AXIS	Accuracy grade									
			0	1	2	3	4	5	6	7	8	10
CNC Machinery Tools	Lathes	X	•	•	•	•	•					
		Z				•	•	•				
	Milling machines Boring machines	X		•	•	•	•	•				
		Y		•	•	•	•	•				
	Machine Center	Z			•	•	•	•				
		X		•	•	•	•					
		Y		•	•	•	•					
	Jig borers	Z			•	•	•					
		X	•	•								
		Y	•	•								
	Drilling machines	Z	•	•								
		X				•	•	•				
		Y				•	•	•				
	Grinders	Z					•	•	•			
		X	•	•	•							
		Y		•	•	•						
	EDM	Z			•	•	•	•				
		X		•	•	•						
		Y		•	•	•						
	Wire cut EDM	Z			•	•	•	•				
X			•	•	•							
Y			•	•	•							
U			•	•	•	•						
Laser Cutting Machine	V		•	•	•	•						
	X			•	•	•						
	Y			•	•	•						
General Machinery	Punching Press	Z			•	•	•					
		Y			•	•	•					
	Single Purpose Machines			•	•	•	•	•				
	Wood working Machines								•	•	•	•
	Industrial Robot ( Precision )			•	•	•	•					
	Industrial Robot ( General )							•	•	•	•	
	Coordinate Measuring Machine		•	•	•							
	Non-CNC Machine					•	•	•				
	Transport Equipment						•	•	•	•	•	•
	X-Y Table			•	•	•	•	•				
	Linear Actuator							•	•	•	•	
	Aircraft Landing Gear							•	•	•	•	
	Airfoil Control							•	•	•	•	
	Gate Valve								•	•	•	•
	Power steering								•	•	•	
	Glass Grinder				•	•	•	•	•			
	Surface Grinder						•	•				
	Induction Hardening Machine								•	•	•	•
	Electromachine			•	•	•	•	•	•			
	All-electric injection molding machine								•	•	•	•

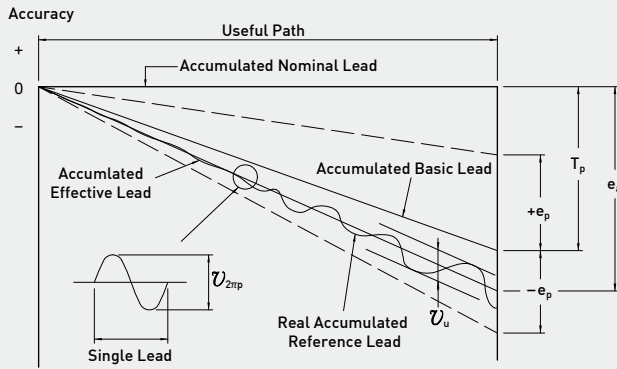

$T_p$  : Target point of accumulated lead.  
This value is determined by customers' different application requirements.

$e_p$  : Total reference lead deviation.  
Maximum deviation for accumulated reference lead line over the full length.

$v_{2\pi p}$  : Single lead variation.

$e_a$  : Real accumulated reference lead measured by laser system.

$v_u$  : Total relative lead deviation.  
Maximum deviation of the real accumulated lead from the real accumulated reference lead in the corresponding range.

$v_{300p}$  : Lead deviation over path of 300mm.  
The above deviation in random 300 mm within thread length.

Fig 4.12 HIWIN lead measuring curve of precision ballscrew

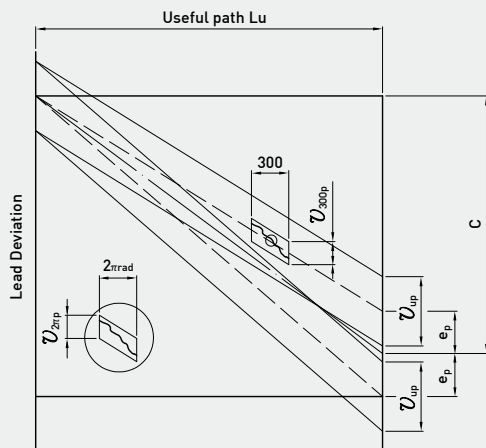
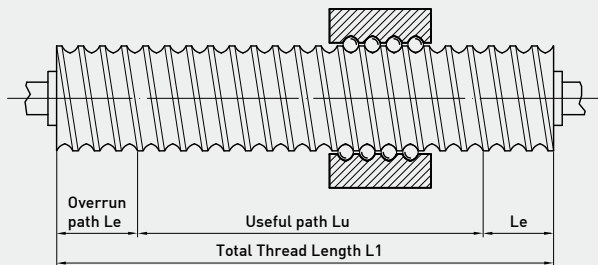

$e_{oa}$  : Average lead deviation over useful path  $L_u$ .  
A straight line representing the tendency of the cumulative actual lead.  
This is obtained by the least square method and measured by the laser system. The value is added by path compensation over the useful path and the mean travel deviation.

$C$  : Path compensation over useful path  $L_u$ .  
Selection parameter: This value is determined by customer and maker as it depends on different application requirements.

$e_p$  : Mean travel deviation.

$v_{up}$  : Lead variation over useful path  $L_u$ .

$v_{300p}$  : Lead variation over path of 300 mm.

$v_{2\pi p}$  : Lead variation over 1 rotation.

Fig 4.13 DIN lead measuring curve of precision ballscrew

AVERAGE LEAD DEVIATION OVER USEFUL PATH L<sub>U</sub>

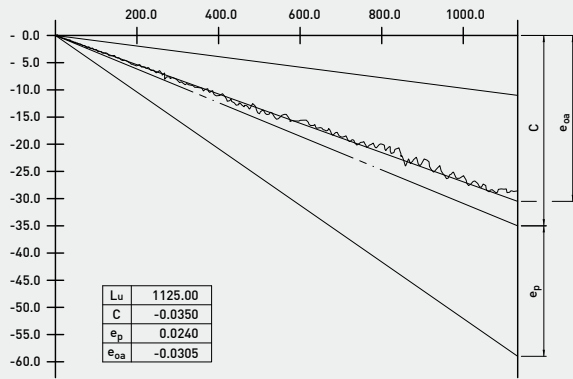

• e<sub>0a</sub>(E<sub>a</sub>) :

Lead deviation over useful thread length relative to the nominal deviation.  
 (This measurement is made according to DIN standard 69051-3-1).  
 $C(T) - e_p(E_p) \leq e_{0a}(E_a) \leq C(T) + e_p(E_p)$

LEAD VARIATION OVER USEFUL PATH L<sub>U</sub>

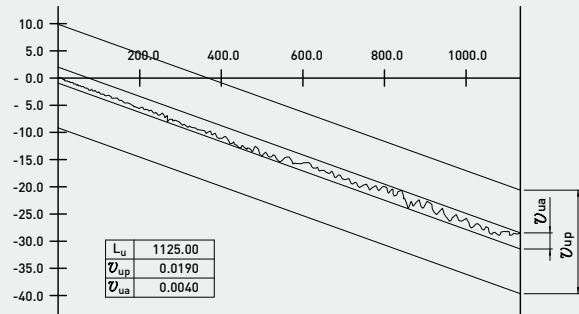

• v<sub>0a</sub>(e<sub>a</sub>) :

Total relative lead variation over useful thread length.  
 (This measurement is made according to DIN standard 69051-3-2).  
 $v_{0a}(e_a) \leq v_{up}(e_p)$

LEAD VARIATION OVER PATH OF 300MM

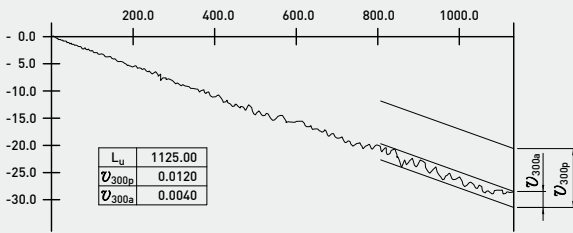

• v<sub>300a</sub>(e<sub>300a</sub>) :

Relative lead variation in random 300mm length within thread length.  
 (This measurement is made according to DIN standard 69051-3-3).  
 $v_{300a}(e_{300a}) \leq v_{300p}(e_{300p})$

LEAD VARIATION OVER 1 ROTATION

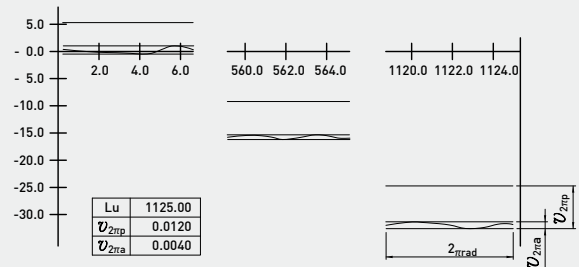

• v<sub>2ra</sub>(e<sub>2ra</sub>) :

Single lead variation over 2p.  
 (This measurement is made according to DIN standard 69051-3-4).  
 $v_{2ra}(e_{2ra}) \leq v_{2rp}(e_{2rp})$

Fig 4.14 Lead accuracy measuring chart from dynamic laser measurement equipment according to DIN 69051 standard

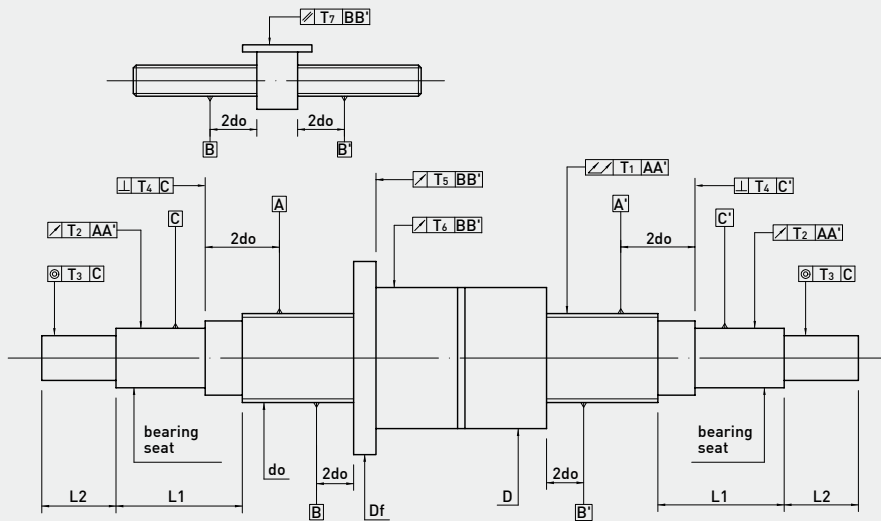
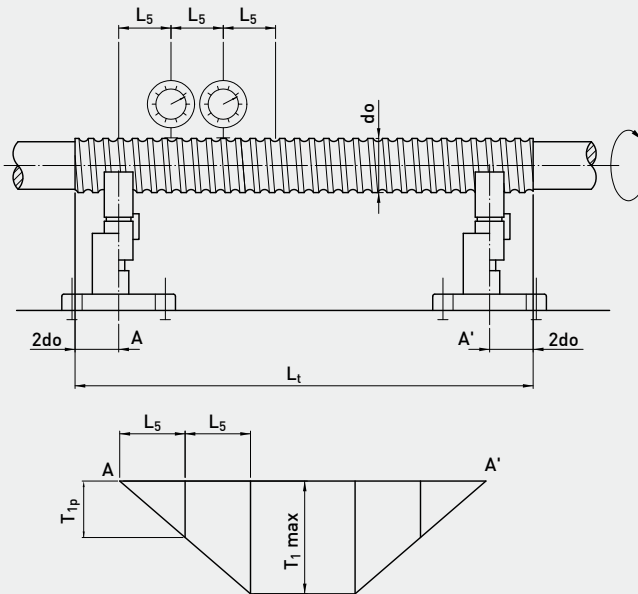

Fig 4.15 Geometrical tolerance of HIWIN precision ground ballscrew

Table 4.6 Tolerance table and measurement method for HIWIN precision ballscrews



T1: True running deviation of external diameter relative to AA' (This measurement is made according to DIN 69051 and JIS B1192)

Nominal Diameter do ( mm )		reference length	T <sub>1p</sub> [ μm ] For HIWIN tolerance class							
above	up to	L <sub>5</sub>	0	1	2	3	4	5	6	7
6	12	80								
12	25	160								
25	50	315	20	20	20	23	25	28	32	40
50	100	630								
100	200	1250								
L <sub>t</sub> /do		T <sub>1max</sub> [ μm ] ( for L <sub>t</sub> ≥ 4L <sub>5</sub> ) For HIWIN tolerance class								
above	up to	0	1	2	3	4	5	6	7	
	40	40	40	40	45	50	60	64	80	
40	60	60	60	60	70	75	85	96	120	
60	80	100	100	100	115	125	140	160	200	
80	100	160	160	160	180	200	220	256	320	

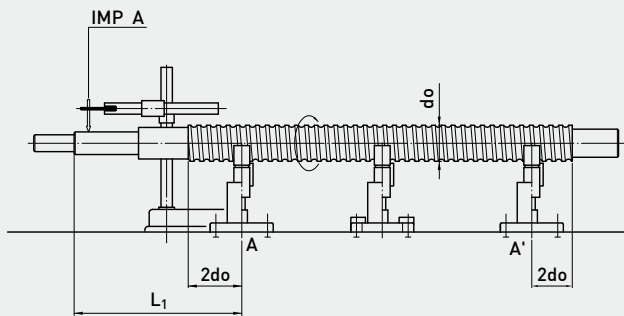

T2: Run out deviation of bearing relative to AA' (This measurement is made according to DIN 69051 and JIS B1192)

Nominal Diameter do ( mm )		reference length	T <sub>2p</sub> [ μm ] ( for L <sub>1</sub> ≤ L <sub>r</sub> ) For HIWIN tolerance class							
above	up to	L <sub>r</sub>	0	1	2	3	4	5	6	7
6	20	80	6	8	10	11	12	16	20	40
20	50	125	8	10	12	14	16	20	25	50
50	125	200	10	12	16	18	20	26	32	63
125	200	315	-	-	-	20	25	32	40	80

if  $L_1 > L_r$ , then  $t_{2a} \leq T_{2p} \frac{L_1}{L_r}$

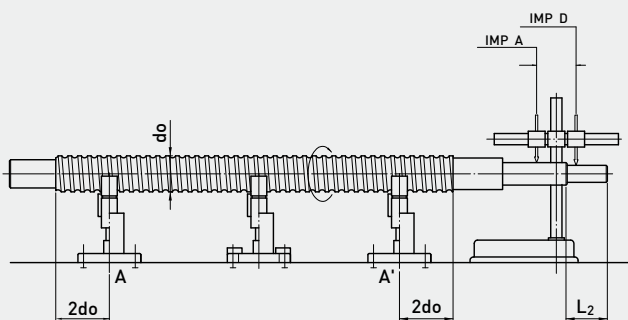

T3: Coaxial deviation relative to AA' (This measurement is made according to DIN 69051 and JIS B1192)

Nominal Diameter do ( mm )		reference length	T <sub>3p</sub> [ μm ] ( for L <sub>2</sub> ≤ L <sub>r</sub> ) For HIWIN tolerance class							
above	up to	L <sub>r</sub>	0	1	2	3	4	5	6	7
6	20	80	4	5	5	6	6	7	8	12
20	50	125	5	6	6	7	8	9	10	16
50	125	200	6	7	8	9	10	11	12	20
125	200	315	-	-	-	10	12	14	16	25

if  $L_2 > L_r$ , then  $t_{3a} \leq T_{3p} \frac{L_2}{L_r}$

Table 4.6 Tolerance table and measurement method for HIWIN precision ballscrews

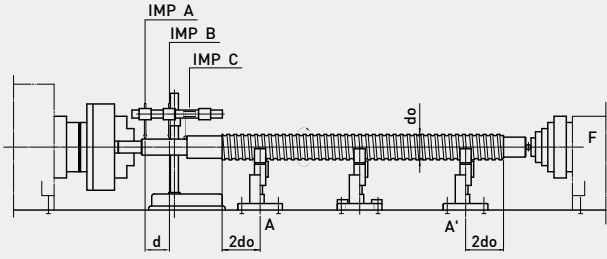

T4 : Run-out deviation of bearing end shoulder relative to AA' (This measurement is made according to DIN 69051 and JIS B1192)

Nominal Diameter do ( mm )		T <sub>sp</sub> [ μm ] For HIWIN tolerance class							
above	up to	0	1	2	3	4	5	6	7
6	63	3	3	3	4	4	5	5	6
63	125	3	4	4	5	5	6	6	8
125	200	-	-	-	6	6	8	8	10

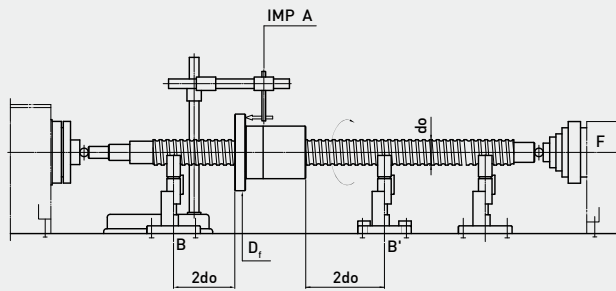

T5 : Face running deviation of locating face (only for nut) relative to BB' (This measurement is made according to DIN 69051 and JIS B1192)

Nut Flange Diameter D <sub>1</sub> ( mm )		T <sub>sp</sub> [ μm ] For HIWIN tolerance class							
above	up to	0	1	2	3	4	5	6	7
-	20	5	6	7	8	9	10	12	14
20	32	5	6	7	8	9	10	12	14
32	50	6	7	8	8	10	11	15	18
50	80	7	8	9	10	12	13	16	18
80	125	7	9	10	12	14	15	18	20
125	160	8	10	11	13	15	17	19	20
160	200	-	11	12	14	16	18	22	25
200	250	-	12	14	15	18	20	25	30

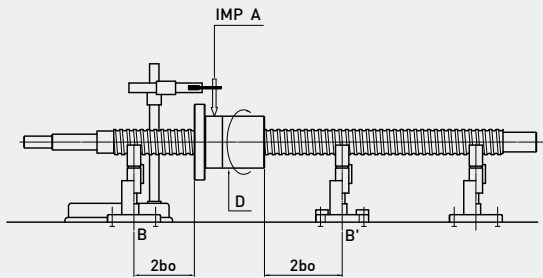

T6 : Run-out deviation of external diameter (only for nut) relative to BB' (This measurement is made according to DIN 69051 and JIS B1192)

Nut Diameter Diameter D ( mm )		T <sub>sp</sub> [ μm ] For HIWIN tolerance class							
above	up to	0	1	2	3	4	5	6	7
-	20	5	6	7	9	10	12	16	20
20	32	6	7	8	10	11	12	16	20
32	50	7	8	10	12	14	15	20	25
50	80	8	10	12	15	17	19	25	30
80	125	9	12	16	20	24	22	25	40
125	160	10	13	17	22	25	28	32	40
160	200	-	16	20	22	25	28	32	40
200	250	-	17	20	22	25	28	32	40

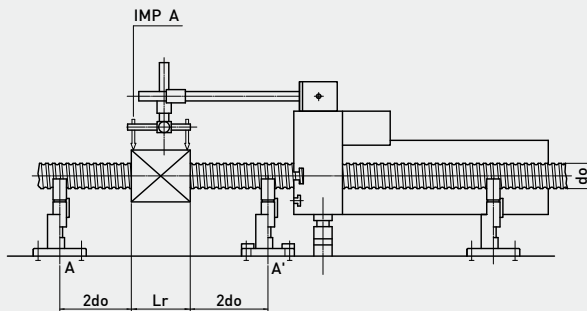

T7 : Deviation of parallelism (only for nut) relative to BB' (This measurement is made according to DIN 69051 and JIS B1192 )

Mounting basic length ( mm ) L <sub>r</sub>		T <sub>sp</sub> [ μm ] / 100mm For HIWIN tolerance class							
above	up to	0	1	2	3	4	5	6	7
-	50	5	6	7	8	9	10	14	17
50	100	7	8	9	10	12	13	15	17
100	200	-	10	11	13	15	17	24	30

## 4.4 Preload Methods

The specially designed Gothic ball track can make the ball contact angle around  $45^\circ$ . The axial force  $F_a$  which comes from an outside drive force or inside preload force, causes two kinds of backlash. One is the normal backlash,  $S_a$  caused by the manufacturing clearance between ball track and ball. The other is the deflection backlash,  $\Delta\ell$  caused by the normal force  $F_n$  which is perpendicular to the contact point.

The clearance backlash can be eliminated by the use of a preload internal force  $P$ . This preload can be obtained via a double nut, an offset pitch single nut, or by adjusting the ball size for preloaded single nuts.

The deflection backlash is caused by the preload internal force and the external loading force and is related to that of the effect of lost motion.

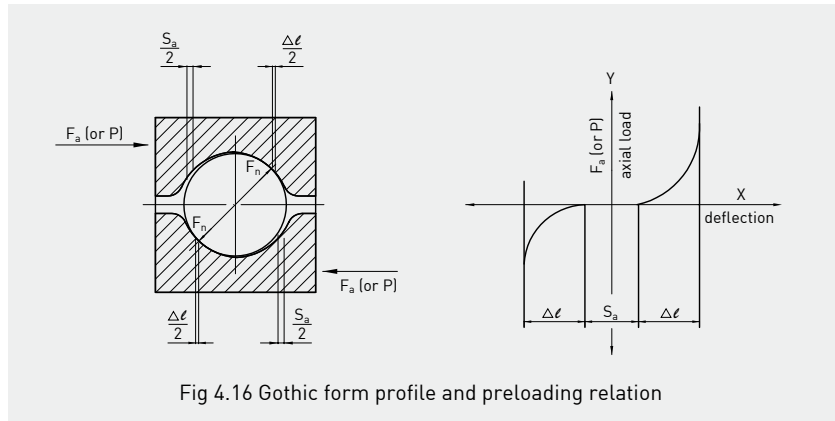

Fig 4.16 Gothic form profile and preloading relation

### (1) Double nut preloading

Preload is obtained by inserting a spacer between the 2 nuts (Fig. 4.17). “Tension preload” is created by inserting an oversize spacer and effectively pushing the nuts apart. “Compression pre-load” is created by inserting an undersize spacer and correspondingly pulling nuts together. Tension preload is primarily used for precision ballscrews. However, compression preload type ballscrews are also available upon your request. If pretension is necessary to increase stiffness, please contact us for the amount of pretension to be used in the ballscrew journal ends. (0.02mm to 0.03mm per meter is recommended, but the T value should be selected according to the compensation purpose).

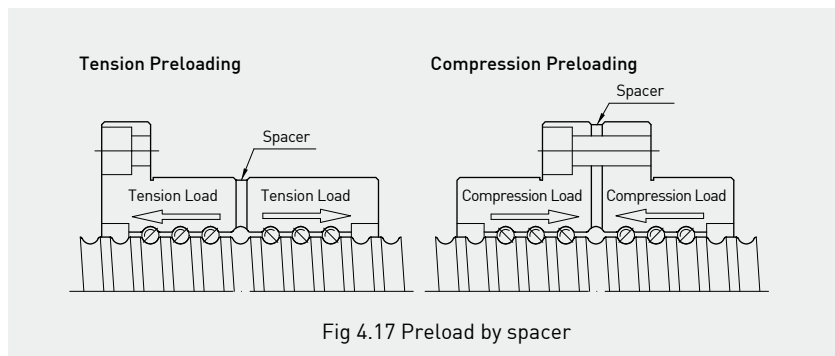

Fig 4.17 Preload by spacer

### (2) Single nut preloading

There are two ways of preloading a single nut. One is called “the oversized-ball preloading method”. The method is to insert balls slightly larger than the ball groove space (oversized balls) to allow balls to contact at four points (Fig. 4.18).

The other way is called “The offset pitch preloading method” as shown in Fig. 4.19. The nut is ground to have a  $\delta$  value offset on the center pitch. This method is used to replace the traditional double nut preloading method and has the benefit of a compact single nut with high stiffness via small preload force. However, it should not be used in heavy duty preloading. The best preload force is below 5% of dynamic load (C).

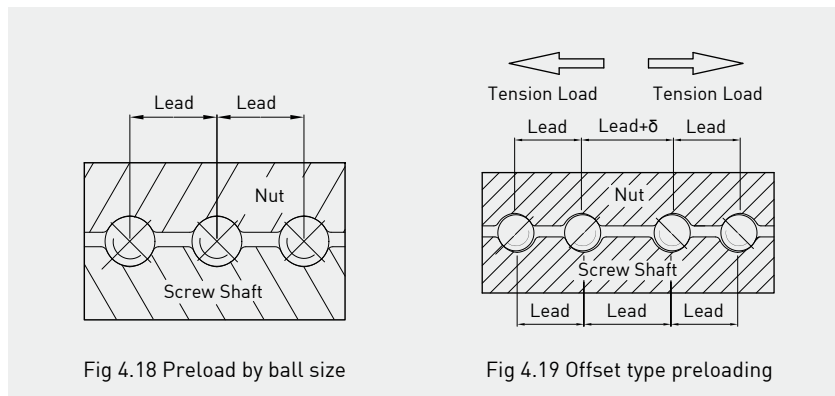

Fig 4.18 Preload by ball size

Fig 4.19 Offset type preloading

### (3) Preload calculation

$$p = \frac{F_{bm}}{2.8} \dots\dots\dots \text{M1}$$

P : preload force ( kgf )

F<sub>bm</sub> : Mean operating load(kgf)  
(Ref.M8~M10)

$$T_d = \frac{K_p \times P \times \ell}{2\pi} \dots\dots\dots \text{M2}$$

Preload drag torque (Fig. 4.20)

T<sub>d</sub> : preload drag torque (kgf-mm)

P : preload (kgf)

ℓ : lead (mm)

K<sub>p</sub> : preload torque coefficient \*\*

K<sub>p</sub> :  $\frac{1}{\eta_1} - \eta_2$  (is between 0.1 and 0.3)

η<sub>1</sub>, η<sub>2</sub> are the mechanical efficiencies of the ballscrew.

#### (1) For common transmission (to convert rotary motion to linear motion)

$$\eta_1 = \frac{\tan(\alpha)}{\tan(\alpha + \beta)} = \frac{1 - \mu \tan \alpha}{1 + \mu / \tan \alpha} \dots\dots\dots \text{M3}$$

#### (2) For reverse transmission (to convert linear rotary motion to rotary motion)

$$\eta_2 = \frac{\tan(\alpha - \beta)}{\tan(\alpha)} = \frac{1 - \mu / \tan \alpha}{1 + \mu \tan \alpha} \dots\dots\dots \text{M4}$$

$$\alpha = \tan^{-1} \frac{\ell}{\pi D_m} \dots\dots\dots \text{M5}$$

$$\beta = \tan^{-1} \mu \dots\dots\dots \text{M6}$$

α : lead angle (degrees)

D<sub>m</sub> : pitch circle diameter of screw shaft (mm)

ℓ : lead (mm)

β : friction angle (0.17°~0.57°)

μ : friction coefficient (0.003~0.01)

$$** K_p = \frac{0.05}{\sqrt{\tan \alpha}}$$

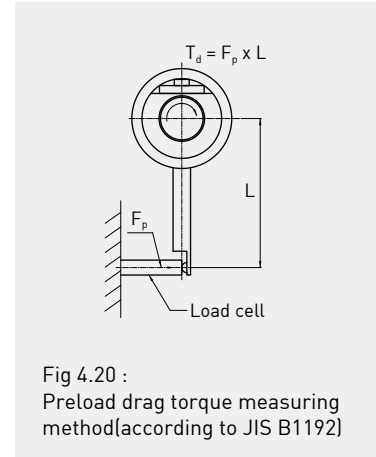

### (4) Uniformity of preload drag torque

#### (1) Measuring method

Preload creates drag torque between the nut and screw. It is measured by rotating the screw spindle at constant speed while restraining the nut with a special fixture as shown in Fig. 4.20. The load cell reading force Fp is used to calculate the preload drag torque of the ballscrew.

HIWIN has developed a computerized drag torque measuring machine which can accurately monitor the drag torque during screw rotation. Therefore, the drag torque can be adjusted to meet customer requirements (Fig. 2.5). The measurement standard for preload drag torque is shown in Fig. 4.21 and Table 4.7.

#### (2) Measuring conditions

1. Without wiper.
2. The rotating speed, 100 rpm.
3. The dynamic viscosity of lubricant, 61.2 ~74.8 cSt (mm/s) 40°C, that is, ISO VG 68 or JIS K2001.
4. The return tube up.

(3) The measurement result is illustrated by the standard drag torque chart. Its nomenclature is shown in Fig. 4.21.

(4) The allowable preload drag torque variation as a function of accuracy grade is shown in Table 4.7.



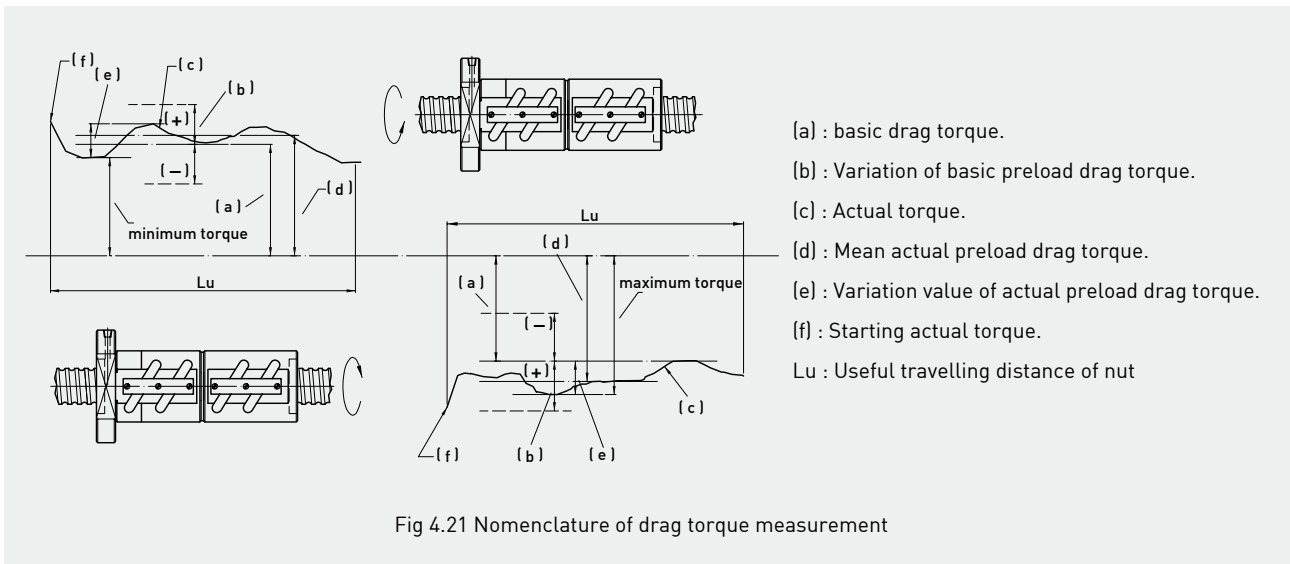

Fig 4.21 Nomenclature of drag torque measurement

Table 4.7 : Variation range for preload drag torque [According to JIS B1192]

Unit: ± %

[1] Basic Dragtorque (kgf - cm)		Useful stroke length of thread (mm)																															
		4000 mm maximum														over 4000 mm																	
		Slender ratio ≤ 40														40 < Slender ratio < 60																	
		Accuracy grade														Accuracy grade																	
Above	Up To	0	1	2	3	4	5	6	7	0	1	2	3	4	5	6	7	0	1	2	3	4	5	6	7								
2	4	30	35	40	40	45	50	60	-	40	40	50	50	60	60	70	-	-	-	-	-	-	-	-	-	-	-	-	-	-	-	-	-
4	6	25	30	35	35	40	40	50	-	35	35	40	40	45	45	60	-	-	-	-	-	-	-	-	-	-	-	-	-	-	-	-	-
6	10	20	25	30	30	35	35	40	40	30	30	35	35	40	40	45	45	-	-	-	40	43	45	50	50	-	-	-	-	-	-	-	-
10	25	15	20	25	25	30	30	35	35	25	25	30	30	35	35	40	40	-	-	-	35	38	40	45	45	-	-	-	-	-	-	-	-
25	63	10	15	20	20	25	25	30	30	20	20	25	25	30	30	35	35	-	-	-	30	33	35	40	40	-	-	-	-	-	-	-	-
63	100	-	15	15	15	20	20	25	30	-	-	20	20	25	25	30	35	-	-	-	25	23	30	35	35	-	-	-	-	-	-	-	-

- Note :
1. Slender ratio=Thread length of spindle/ Nominal spindle O.D.(mm)
  2. Refer to the designing section of the manual to determine the basic preload drag torque.
  3. Table 4.9 shows the conversion table for Nm.
  4. For more information, please contact our engineering department.

## 4.5 Calculation Formulas

### Service life

- The average number of rpm,  $n_{av}$

$$n_{av} = n_1 \times \frac{t_1}{100} + n_2 \times \frac{t_2}{100} + n_3 \times \frac{t_3}{100} + \dots$$

$n_{av}$  : average speed (rpm)

$n$  : speed (rpm)

$\frac{t_1}{100}$  : % of time at speed  $n_1$  etc.

M7

- The average operating load  $F_{bm}$   
(1) With variable load and constant speed

$$F_{bm} = \sqrt[3]{F_{b1}^3 \times \frac{t_1}{100} \times f_p^3 + F_{b2}^3 \times \frac{t_2}{100} \times f_p^3 + F_{b3}^3 \times \frac{t_3}{100} \times f_p^3} \dots\dots \text{M8}$$

$F_{bm}$  : average operating load (kgf);  $F_b$  : working axial load  
 $f_p$  : operation condition factor  
 $f_p$  : 1.1 ~ 1.2 when running without impact  
 1.3 ~ 1.8 when running in the normal condition  
 2.0 ~ 3.0 when running with heavy impact and vibration

- (2) With variable load and variable speed

$$F_{bm} = \sqrt[3]{F_{b1}^3 \times \frac{n_1}{n_{av}} \times \frac{t_1}{100} \times f_p^3 + F_{b2}^3 \times \frac{n_2}{n_{av}} \times \frac{t_2}{100} \times f_p^3 + F_{b3}^3 \times \frac{n_3}{n_{av}} \times \frac{t_3}{100} \times f_p^3} \dots\dots \text{M9}$$

- (3) With linear variable load and constant speed

$$F_{bm} = \frac{F_{b \min} \times f_{p1} + 2 \times F_{b \max} \times f_{p2}}{3} \dots\dots \text{M10}$$

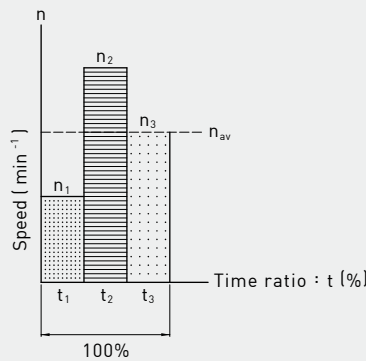

Fig 4.22 Equivalent speed

### Example 4.5 - 1

A HIWIN ballscrew is subjected to the following operating conditions. Calculate the average running speed and operating load.

Operating Condition :

For smooth running without impact  $f_p = 1.1$

Condition	Axial load (kgf)	Revolution (rpm)	Loading time ratio (%)
	(Fb)	(n)	(t)
1	100	1000	45
2	400	50	35
3	800	100	20

Calculation

$$n_{av} = 1000 \times \frac{45}{100} + 50 \times \frac{35}{100} + 100 \times \frac{20}{100} = 487.5 \text{rpm (ref.M7)}$$

$$F_{bm} = \sqrt[3]{100^3 \times \frac{1000}{487.5} \times \frac{45}{100} \times 1.1^3 + 400^3 \times \frac{50}{487.5} \times \frac{35}{100} \times 1.1^3 + 800^3 \times \frac{100}{487.5} \times \frac{20}{100} \times 1.1^3} = 318.5 \text{ kgf}$$

## The resultant axial force, $F_a$

For a single nut without preload

$$F_a = F_{bm} \quad \dots\dots\dots \text{M11}$$

For a single nut with preload P

$$F_a \leq F_{bm} + P \quad \dots\dots\dots \text{M12}$$

## Expected service life

### For single nut

- Service life represented in revolutions :

$$L = \left( \frac{C}{F_a} \right)^3 \times 10^6 \quad \dots\dots\dots \text{M13}$$

L : Service life in running revolution (revolutions)

C : dynamic load rating (kgf) ( $10^6$  rev)

### For symmetrical preload double nut arrangement

- (a) Service life represented in revolutions :

$$F_{bm}(1) = P \left( 1 + \frac{F_{bm}}{3P} \right)^{3/2} \quad L(1) = \left( \frac{C}{F_{bm}(1)} \right)^3 \times 10^6$$

$$F_{bm}(2) = F_{bm}(1) - F_{bm} \quad L(2) = \left( \frac{C}{F_{bm}(2)} \right)^3 \times 10^6$$

$$L = [L(1)^{-10/9} + L(2)^{-10/9}]^{-9/10} \quad \dots\dots\dots \text{M14}$$

L = Service life in running revolution (revolutions)

C : Preload force (kgf)

- (b) conversion from revolutions to hours :

$$L_h = \frac{L}{n_{av} \times 60} \quad \dots\dots\dots \text{M15}$$

$L_h$  : Service life in hours (hours)

$n_{av}$  : Average speed (rpm, Ref. M7)

- (c) Conversion from travel distance to hours:

$$L_h = \left( \frac{L_d \times 10^6}{\ell} \right) \times \frac{1}{n_{av} \times 60} \quad \dots\dots\dots \text{M16}$$

$L_h$  : Running life (in hours)

$L_d$  : Running life (in distance, Km)

$\ell$  : Ballscrew lead (mm per rev)

$n_{av}$  : Average running speed (rpm)

(d) the modified service life for different reliability factors is calculated by

$$L_m = L \times f_r \quad \dots\dots\dots \text{M17}$$

$$L_{hm} = L_h \times f_r \quad \dots\dots\dots \text{M18}$$

with the reliability factor  $f_r$  ( Table 4.8)

Table 4.8 Reliability factor for service life

Reliability %	$f_r$
90	1
95	0.63
96	0.53
97	0.44
98	0.33
99	0.21

**Example 4.5 - 2**

By the example 4.5-1, if the design service life of the ballscrew is 3500 hours, lead = 10mm, single nut with zero backlash, find the nominal diameter of the HIWIN ballscrew.

Calculation

$$P = \frac{F_{bm}}{2.8} = \frac{318.5}{2.8} = 114 \text{ kgf} \quad (\text{Assume zero backlash when } F_{bm} = 318.5 \text{ kgf})$$

$$F_a = F_{bm} + p = 318.5 + 114 = 432.5 \text{ kgf} \quad (\text{Ref formula M1})$$

$$L = L_h \times n_{av} \times 60 = 3500 \times 487.5 \times 60 = 1.02375 \times 10^8 \quad (\text{revolutions})$$

$$C' = F_a \left( \frac{L}{10^6} \right)^{1/3} = 432.5 \times \left( \frac{1.02375 \times 10^8}{10^6} \right)^{1/3} = 2023 \text{ kgf} \quad C' \leq \text{rating}$$

So, from the dimensions table of HIWIN ballscrews, select FSV type nut with spindle nominal diameters equals 32mm and C1 circuits which can satisfy this application.

**Example 4.5 - 3**

If the ballscrew nominal diameter=50mm, lead=8mm, and service life  $L=7 \times 10^6$  revolutions, find the permissible load on the screw spindle.

Calculation

From the dimensions table of HIWIN ballscrew, the FSV type ballscrew with nominal diameter=50 mm, lead=8 mm and B3 type return tube has the dynamic load rating  $C=5674$ .

$$F_a = C \div \left( \frac{L}{10^6} \right)^{1/3} = 5674 \div \left( \frac{7 \times 10^6}{10^6} \right)^{1/3} = 2966 \text{ kgf}$$

Drive torque and drive power for the motor

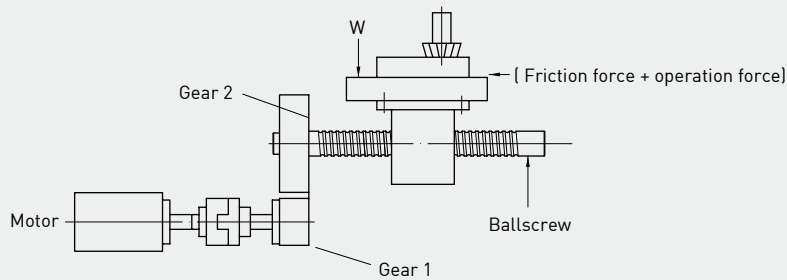

Fig 4.23 Load operation by ballscrew

Fig. 4.23 shows the terms for a feed system operated by ballscrew. The formula for motor drive torque is given below :

(a) Common transmission (to convert rotary motion to linear motion)

$$T_a = \frac{F_b \times \ell}{2\pi\eta_1} \dots\dots\dots \text{M19}$$

$T_a$  = Drive torque for common transmission (kgf-mm)

$F_b$  = Axial load (kgf)

$F_b = F_{bm} + \mu \times W$  (for horizontal motion)

$\ell$  = Lead (mm)

$\eta_1$  = Mechanical efficiency (0.9~0.95, Ref. M3)

$W$  = Table wight + Work piece weight (kgf)

$\mu$  = Friction coefficient of table guide way

(b) Reverse transmission (to convert linear motion to rotary motion)

$$T_c = \frac{F_b \times \ell \times \eta_2}{2\pi} \dots\dots\dots \text{M20}$$

$\eta_2$  = Mechanical efficiency (0.9~0.95, Ref. M4)

$T_c$  = Torque for reverse transmission (kgf-mm)

(c) Motor drive torque

For normal operation :

$$T_M = (T_a + T_b + T_d) \times \frac{N_1}{N_2} \dots\dots\dots \text{M21}$$

$T_M$  = Motor drive torque (kgf-mm)

$T_b$  = Friction torque of supporting bearing (kgf-mm)

$T_d$  = Preload drag torque (kgf-mm, Ref. M2)

$N_1$  = Number of teeth for driver gear

$N_2$  = Number of teeth for driven gear

For acceleration operation :

$$T'a = J\alpha \dots\dots\dots \text{M22}$$

$T'a$  : Motor drive torque during acceleration (kgf)

$J$  : System inertia (kgf-mm-sec<sup>2</sup>)

$\alpha$  : Angular acceleration (rad/sec<sup>2</sup>)

$$\alpha = \frac{2\pi N_{dif}}{60t_a} \dots\dots\dots \text{M23}$$

$N_{dif} = \text{rpm}_{\text{stage2}} - \text{rpm}_{\text{stage1}}$

$t_a$  = acceleration rising time (sec)

$$J = J_M + J_{G1} + J_{G2} \left( \frac{N_1}{N_2} \right)^2 + \frac{1}{2g} W_s \left( \frac{D_N}{2} \right)^2 \left( \frac{N_1}{N_2} \right)^2 + \frac{W}{g} \left( \frac{\ell}{2\pi} \right)^2 \left( \frac{N_1}{N_2} \right)^2 \dots\dots\dots \text{M24}$$

= Motor inertia + Equivalent gear inertia + Ballscrew inertia + Load inertia (Fig.4.23)

$W_s$  : Ballscrew weight (kgf)

$D_N$  : Ballscrew nominal diameter (mm)

$g$  : Gravity coefficient (9800 mm/sec<sup>2</sup>)

$J_M$  : Inertia of motor (kgf-mm-sec<sup>2</sup>)

$J_{G1}$  : Inertia of driver gear (kgf-mm-sec<sup>2</sup>)

$J_{G2}$  : Inertia of driver gear (kgf-mm-sec<sup>2</sup>)

Total operating torque :

$$T_{Ma} = T_M + T'_a \quad \dots\dots\dots \text{M25}$$

$T_{Ma}$  = Total operating torque (kgf)

The inertia of a disc is calculated as following :

For disc with concentric O.D.

$$J = \frac{1}{2g} \pi \rho_d R^2 L \quad \dots\dots\dots \text{M26}$$

$J$  : Disc inertia (kgf • mm • sec<sup>2</sup>)

$\rho_d$  : Disc specific weight ( $7.8 \times 10^{-6}$  kgf/mm<sup>3</sup>) for steel

$R$  : Disc radius (mm)

$L_d$  : Disc length (mm)

$g$  : Gravity coefficient (9800 mm/sec<sup>2</sup>)

(d) Drive power

$$P_d = \frac{T_{pmax} \times N_{max}}{974} \quad \dots\dots\dots \text{M27}$$

$P_d$  : Maximum drive power (watt) safety

$T_{pmax}$  : Maximum drive torque (safety factor ×  $T_{ma}$ , kgf-mm )

$T_{max}$  : Maximum rotation speed (rpm)

(e) Check the acceleration time

$$t_a = \frac{J}{T_{MI} - T_L} \times \frac{2\pi N_{max}}{60} \cdot f \quad \dots\dots\dots \text{M28}$$

$t_a$  = Acceleration rising time

$J$  = Total inertia moment

$T_{MI} = 2 \times T_{mr}$

$T_{Mr}$  = Motor rated torque

$T_L$  = Drive torque at rated feed

$f$  = Safety factor = 1.5

Table 4.9 : Shows the conversion relationship of different measurement units for the motor torque or preload drag torque.

Table 4.9 Conversion table for motor torque

kgf - cm	kgf - mm	Nm	kpm ( kgf - m )	OZ - in	ft - l bf
1	10	$9.8 \times 10^{-2}$	$10^{-2}$	13.8874	$7.23301 \times 10^{-2}$
0.1	1	$9.8 \times 10^{-3}$	$1.0 \times 10^{-3}$	1.38874	$7.23301 \times 10^{-3}$
10.19716	$1.019716 \times 10^2$	1	0.1019716	$1.41612 \times 10^2$	0.737562
$10^2$	$10^3$	9.80665	1	$1.38874 \times 10^3$	7.23301
$7.20077 \times 10^{-2}$	0.720077	$7.06155 \times 10^{-3}$	$7.20077 \times 10^{-4}$	1	$5.20833 \times 10^3$
13.82548	$1.382548 \times 10^2$	1.35582	0.1382548	$1.92 \times 10^2$	1

**Example 4.5 - 4**

Consider the machining process driven by the motor and ballscrew as Fig. 4.24.

Table weight  $W_1 = 200$  kgf

Work weight  $W_2 = 100$  kgf

Friction coefficient of slider  $\mu = 0.02$

Operating condition : Smooth running without impact

Axial feed force (kgf)	Revolution (rpm)	Loading time ratio (%)
100	500	20
300	100	50
500	50	30

Acceleration speed : 100 rad/sec<sup>2</sup>

Motor Condition : Motor diameter : 50 mm, Motor length : 200 mm,

Gear condition : Driver gear diameter G1 : 80 mm, Thickness : 20 mm, Teeth : 30

Driven gear diameter G2 : 240 mm, Thickness : 20 mm, Teeth : 90

Ballscrew condition :

Nominal diameter : 50 mm, Pitch : 10 mm

Length : 1200 mm, Weight : 18 kgf

No backlash when axial feed force = 300 kgf

Bearing torque  $T_b = 10$  kgf·mm

Mechanical efficiency  $\eta_1 = 0.80$

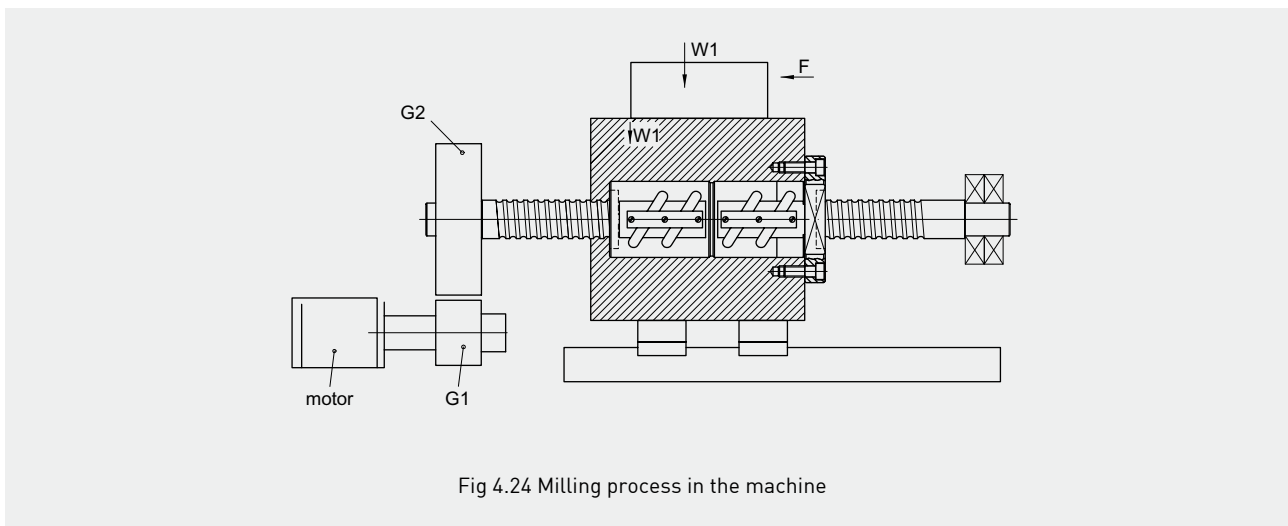

Fig 4.24 Milling process in the machine

### Calculation

(1) Motor drive torque in normal rating condition :

$$n_{av} = 500 \times \frac{20}{100} + 100 \times \frac{20}{100} + 50 \times \frac{20}{100} = 165 \text{ rpm} \quad (\text{Ref. M7})$$

$$F_1 = 100, F_2 = 300, F_3 = 500$$

$$F_{bm} = \sqrt[3]{100^3 \times 1 \times \frac{20}{100} \times \frac{500}{165} \times 300^3 \times 1 \times \frac{50}{100} \times \frac{100}{165} + 500^3 \times 1 \times \frac{30}{100} \times \frac{50}{165}} = 272 \text{ kgf} \quad (\text{Ref. M9})$$

$$P = \frac{300}{2.8} \approx 110 \text{ kgf} \quad (\text{axial feed force} = 300 \text{ kgf}, \text{Ref. M1})$$

$$F_b = F_{bm} + \mu W = 270 + (200 + 100) \times 0.02 = 278 \text{ kgf}$$

$$T_a = \frac{F_b \times \ell}{2\pi\eta_1} = \frac{278 \times 10}{2\pi \times 0.80} = 553 \text{ kgf} \cdot \text{mm} \quad (\text{Ref. M19})$$

$$T_d = 0.2 \times \frac{P \times \ell}{2\pi} = \frac{0.2 \times 110 \times 10}{2\pi} = 35 \text{ kgf} \cdot \text{mm} \quad (\text{Ref. M2})$$

$$T_M = (T_a + T_b + T_d) \times \frac{N_1}{N_2} = (535 + 10 + 35) \times \frac{30}{90} = 199 \text{ kgf} \cdot \text{mm} \quad (\text{Ref. M21})$$

(2) Motor torque in acceleration operation :

(I) Inertia of motor

$$J_M = \frac{1}{2 \times 9800} \times \pi \times 7.8 \times 10^{-6} \times (25)^4 \times 200 = 0.1 \text{ kgf} \cdot \text{mm} \cdot \text{sec}^2$$

(II) Inertia of gear

$$J_{\text{Gear(eq)}} = J_{G1} + J_{G2} \times \left( \frac{N_1}{N_2} \right)^2$$

$$J_{G1} = \frac{1}{2 \times 9800} \times \pi \times 7.8 \times 10^{-6} \times \left( \frac{80}{2} \right)^4 \times 20 = 0.064 \text{ kgf} \cdot \text{mm} \cdot \text{sec}^2$$

$$J_{G2} = \frac{1}{2 \times 9800} \times \pi \times 7.8 \times 10^{-6} \times \left( \frac{240}{2} \right)^4 \times 20 = 5.18 \text{ kgf} \cdot \text{mm} \cdot \text{sec}^2$$

$$J_{\text{Gear(eq)}} = 0.064 + 5.18 \times \left( \frac{30}{90} \right)^2 = 0.640 \text{ kgf} \cdot \text{mm} \cdot \text{sec}^2$$

(III) Inertia of ballscrew

$$J_{\text{ballscrew}} = \frac{1}{2 \times 9800} \times 18 \times \left( \frac{50}{2} \right)^2 \left( \frac{30}{90} \right)^2 = 0.064 \text{ kgf} \cdot \text{mm} \cdot \text{sec}^2$$

(IV) Inertia of load

$$J_{\text{load}} = \frac{300}{9800} \times \left( \frac{10}{2 \times \pi} \right)^2 \times \left( \frac{30}{90} \right)^2 = 0.009 \text{ kgf} \cdot \text{mm} \cdot \text{sec}^2$$

(V) Total inertia

$$J = 0.1 + 0.64 + 0.064 + 0.009 = 0.813 \text{ kgf} \cdot \text{mm} \cdot \text{sec}^2$$

(3) Total motor torque:

$$T'_a = J \cdot \alpha = 0.813 \times 100 = 81.3 \text{ kgf} \cdot \text{mm}$$

$$T_{Ma} = T_M + T'_a = 199 + 81.3 = 280 \text{ kgf} \cdot \text{mm}$$

(4) Drive power:

$$T_{p \max} = 2 \times 280 = 560 \text{ kgf} \cdot \text{mm} \text{ (safety factor} = 2)$$

$$P_d = \frac{560 \times 1500}{974} = 862 \text{ W} = 1.16 \text{ Hp}$$

(5) Selection motor:

Select the DC motor rated torque :  $T_{Mr} > 1.5T_M$ , and maximum motor torque :  $T_{Max} > 1.5T_{pmax}$

Thus the DC servo motor with following specification can be chosen.

Rated output : 950 w

Rated torque : 30 kgf-cm (300 kgf • mm)

Rated rotational speed : 2000 rpm

Maximum torque : 65 kgf x cm (650 kgf • mm)

Moment of inertia of motor : 0.20 kgf • mm • sec<sup>2</sup>

(6) Check the acceleration time:

$$T_L = \left( \frac{F_d \times \ell}{2\pi\eta_1} + T_b + T_d \right) \times \frac{N_1}{N_2} = \left( \frac{100 \times 10}{2\pi \times 0.8} + 10 + 35 \right) \times \frac{30}{90} = 81.3 \text{ kgf} \cdot \text{mm}$$

$$t_a \geq \left( \frac{0.879}{300 \times 2 - 81.3} \right) \times \frac{2\pi \times 2000}{60} \times 1.5 = 0.53 \text{ sec}$$



## Buckling load

The ballscrew shaft when subjected to an axial compressive force may be undergo a visibly large deflection. The axial force is called the buckling load.

$$F_k = 40720 \left( \frac{N_f d_r^4}{L_t^2} \right) \dots\dots\dots \text{M29}$$

$$F_p = 0.5 F_k \dots\dots\dots \text{M30}$$

$F_k$ = Permissible load (kgf)	fixed - fixed	$N_f = 1.0$
$F_p$ : Maximum permissible speed (kgf)	fixed - supported	$N_f = 0.5$
$d_r$ : Root diameter of screw shaft (mm)	supported - supported	$N_f = 0.25$
$L_t$ : distance between support bearing (mm)	fixed - free	$N_f = 0.0625$
$N_f$ : Factor for different mounting types	◆1kgf = 9.8N; 1daN=10N	

The buckling load diagram for different spindle diameter and support method is shown in Fig 4.25.

## Critical speed

The critical speed is said to exist when the rotational frequency of a shaft equals the first natural frequency of the shaft. This will cause the ball screw to bend under the stress of vibration coupled with the centrifugal forces due to the rotation and cause the shaft to vibrate violently. Therefore, the rotational speed of the ball screw should be set to below the value indicated by critical speed.

$$N_c = 2.71 \times 10^8 \times \frac{M_f d_r}{L_t^2} \dots\dots\dots \text{M31}$$

$$N_p = 0.8 N_c \dots\dots\dots \text{M32}$$

$N_c$ = critical speed (rpm)	fixed - fixed	$M_f = 1$
$N_p$ = Maximum permissible load (rpm)	fixed - supported	$M_f = 0.689$
$d_r$ : Root diameter of screw shaft (mm)	supported - supported	$M_f = 0.441$
$L_t$ : distance between support bearing (mm)	fixed - free	$M_f = 0.157$
$M_f$ : Factor for different mounting types		

The critical speed for different spindle and support method is shown in (Fig 4.26).

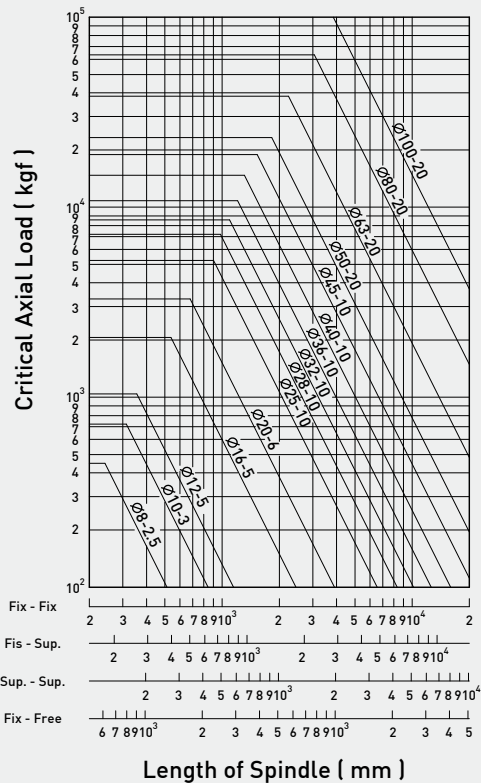

Fig 4.25 Shows the buckling load for different screw spindle diameter and length

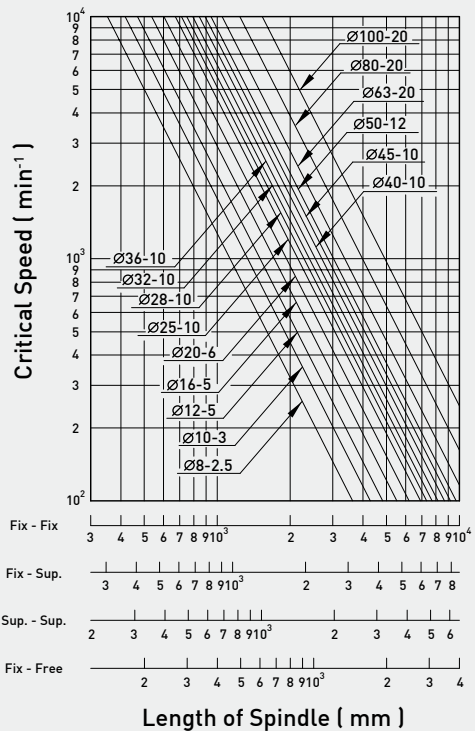

Fig 4.26 shows the critical speed for different screw spindle diameter and length

## D<sub>m</sub>-N value for ballscrew surface speed

D<sub>m</sub>-N value has a strong influence over ballscrew noise, working temperature and service life of return system.

For HIWIN ballscrew,

$$D_m \times N \leq 70,000 \quad \text{M33}$$

$D_m$  : Pitch circle diameter (mm)

$N$  : Maximum speed (rpm)

Ballscrew structure enhancement designed by HIWIN when D<sub>m</sub>-N value ranges from 70,000 to 180,000 . If D<sub>m</sub>-N value above 180,000 , please consult our company.

## Stiffness

Stiffness is an indication of the rigidity of a machine. The stiffness of the ballscrew is determined by nut-spindle rigidity via axial load, balltrack contact rigidity and screw spindle rigidity. When assembling the ballscrew in the machine, the stiffness of support bearing, mounting condition of nut with machine table etc. also should be considered. Fig 4.27 shows the relation of total stiffness of the machine feed system.

From testing, the stiffness of nut-spindle relation and ball and balltrack relation can be combined into the stiffness of nut,  $K_n$ , and listed in dimension table of different nut type. The stiffness of the ballscrew is shown as :

$$\frac{1}{K_{bs}} = \frac{1}{K_s} + \frac{1}{K_n} \quad \text{M34}$$

$K_{bs}$  : Total stiffness of ballscrew (kgf/μm)

The stiffness of the screw spindle is shown as :

$$K_s = 67.4 \frac{d_r^2}{L_1} \text{ (Fixed-Fixed)} \quad \text{M35}$$

$$K_s = 16.8 \frac{d_r^2}{L_1} \text{ (Fixed-Free)} \quad \text{M36}$$

The stiffness chart is shown in Fig 4.28

$$d_r : \text{Root diameter of screw spindle (mm)} \approx D_m - D_b \quad \text{M37}$$

$D_b$  : Diameter of ball (mm)

$K_s$  : Screw spindle stiffness (kgf/μm)

$K_n$  : Nut stiffness (kgf/μm)

The stiffness of the nut is tested using an axial force equal to the highest possible preload of 10% dynamic load (C) and is shown in the dimension table of each nut. When the preload is less than this value, the stiffness of the nut is calculated by extrapolation method as :

$$K_n = 0.8 \times K \left( \frac{P}{0.1C} \right)^{1/3} \quad \text{M38}$$

$K_n$  : Stiffness of nut

$K$  : Stiffness in the dimension table

$P$  : Preload

$C$  : Dynamic load on dimension table

Single nut with backlash is calculated when the external axial force is equal to 0.28 C, thus :

$$K_n = 0.8 \times K \left( \frac{F_b}{2.8 \times 0.1C} \right)^{1/3} \quad \text{M39}$$

The axial stiffness of the whole feed system includes the stiffness of support bearings and nut mounting table. The designer should consider the total stiffness carefully.

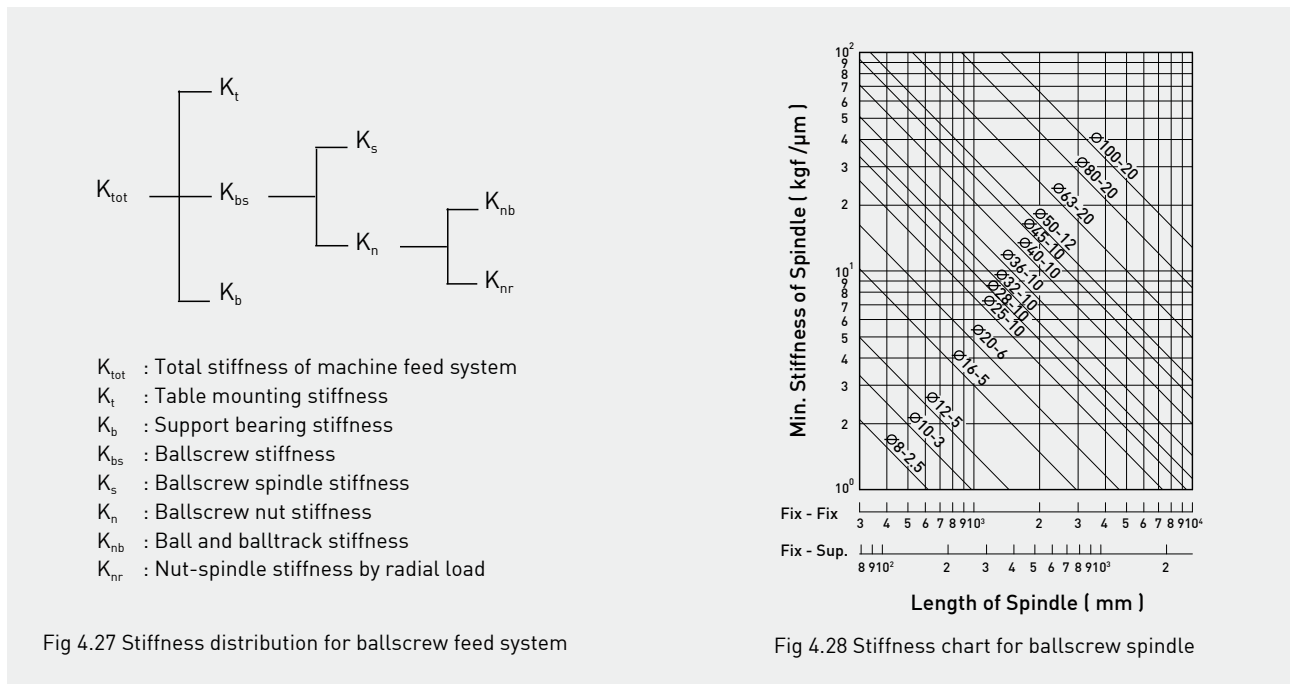

Fig 4.27 Stiffness distribution for ballscrew feed system

Fig 4.28 Stiffness chart for ballscrew spindle

### Thermal expansion

$$\Delta L = 11.6 \times 10^{-6} \times \Delta T \times L_s \quad \text{M40}$$

$\Delta L$  : Thermal expansion of screw spindle (mm)

$\Delta T$  : (°C) Temperature rise at screw spindle

$L_s$  : Total length of screw spindle (mm)

The T value should be chosen to compensate for the temperature rise of the ballscrew. HIWIN recommends a T value of -0.02 ~ -0.03 per meter for CNC machine tools.

### Basic dynamic axial load rating C (theoretical)

The dynamic load is the load at which 90% of the ballscrews will achieve the service life of  $1 \times 10^6$  rev (C). The reliability factor can be adjusted by Table 4.8. The dynamic load is shown on the dimension table of each nut type.

### Basic static axial load rating Co (theoretical)

The static load is the load which will cause the balltrack to have a plastic deformation exceeding  $0.0001 \times$  ball diameter. To calculate the maximum static load of a ballscrew, the static safety factor  $S_f$  of the application condition should be considered.

$$S_f \times F_a(\text{max}) < C_o \quad \text{M41}$$

$S_f$  : Static factor = 2.5 max

$C_o$  : Static load from the dimension table of the nut type

$F_a(\text{max})$  : Maximum static axial load

### Example 4.5 - 5

Ballscrew specification: 1R40-10B2-FSW-1000-1200-0.012	Lead $\ell = 10$ mm
Pitch circle diameter $D_m = 41.4$ mm	Turns = 2.5x2
Ball diameter : 6.35 mm	Lead angle $\alpha = 4.4^\circ$
Root diameter $d_r = 34.91$ mm	Friction angle $\beta = 0.286^\circ$
Column load : fixed - supported	Preload $P = 250$ kgf
Critical speed : fixed - supported	Mean axial force $F_b = 700$ kgf
Stiffness of bearing $K_b = 105$ kgf/ $\mu$ m	$N_f = 0.5$ ; $L_t = 1000$ mm ; $M_f = 0.692$

#### Calculation

##### (1) Buckling load $F_p$

$$F_k = 40720 \times \frac{N_f d_r^4}{L_t^2} = 40720 \times \frac{0.5 \times 34.91^4}{1000^2} = 30240 \text{ kgf (Ref. M29)}$$

$$F_p = 0.5 \times F_k = 0.5 \times 30240 = 15120 \text{ kgf}$$

##### (2) Critical speed $N_p$

$$N_c = 2.71 \times 10^8 \times \frac{0.689 \times 34.90}{1000^2} = 6516 \text{ rpm}$$

$$N_p = 0.8 \times N_c = 0.8 \times 6516 = 5213 \text{ rpm}$$

##### (3) Mechanical efficiency $\eta$ [theoretical]

###### (I) Common transmission

$$\eta_1 = \frac{\tan \alpha}{\tan(\alpha + \beta)} = \frac{\tan(4.396^\circ)}{\tan(4.396^\circ + 0.286^\circ)} = 0.938 \text{ (Ref. M3)}$$

###### (II) Reverse transmission

$$\eta_2 = \frac{\tan(\alpha + \beta)}{\tan \alpha} = \frac{\tan(4.396^\circ + 0.286^\circ)}{\tan(4.396^\circ)} = 0.934 \text{ (Ref. M4)}$$

##### (4) Stiffness $K$

$$K_s = 16.8 \frac{d_r^2}{L_1} = 16.8 \times \frac{34.91^2}{1000} = 20.5 \text{ kgf} / \mu\text{m} \quad p = 250 < 0.1C (=537)$$

$$\therefore K_n = 0.8 \times \left( \frac{P}{0.1C} \right)^{1/3} = 0.8 \times 74 \times \left( \frac{250}{0.1 \times 5370} \right)^{1/3} = 46 \text{ kgf} / \mu\text{m}$$

$$\frac{1}{K} = \frac{1}{K_s} + \frac{1}{K_n} = \frac{1}{20.5} + \frac{1}{46} \quad K = 14.18 \text{ kgf} / \mu\text{m}$$

##### (5) Lost motion during axial force $F_b = 700$ kgf

$$\frac{1}{K_t} = \frac{1}{K} + \frac{1}{K_b} = \frac{1}{14} + \frac{1}{105} \quad K_t = 12.35 \text{ kgf} / \mu\text{m}$$

$$\delta / 2 = \frac{F}{K} = \frac{700}{12.4} = 56 \mu\text{m} = 0.056 \text{ mm} \quad (\text{each way}) \text{ Total lost motion } \delta = 2 \times 0.056 = 0.112 \text{ mm}$$

If the preload increases to  $2 \times 250 = 500$  kgf then  $K_n = 58$  kgf/ $\mu$ m and  $K = 15.1$  kgf/ $\mu$ m. Total stiffness  $K_t = 13.2$  kgf/ $\mu$ m and total lost motion  $\delta = 0.106$  mm. The difference is only  $6 \mu$ m (5% change). comparing with 250 kgf, preloaded nut, but the temperature rise caused by 500 kgf preload is heavy. The spindle stiffness is sometimes more important than the nut stiffness. The best way to increase the stiffness of the system is not in the heavy preloading of the ballscrew nut. If the support method changes to fixed-fixed, then  $K_s = 82$  kgf/ $\mu$ m and  $K_t$  becomes 23 kgf/ $\mu$ m. The total lost motion  $d = 0.061$  mm. The difference is  $51 \mu$ m (45%).

## Manufacturing range

The maximum length to which a ballscrew can be manufactured depends on spindle diameter and accuracy grade (Table 4.10). Since high accuracy ballscrews require a high degree of straightness to the screw spindle, the higher the slender ratio (length/diameter), the more difficult to manufacture and the less the spindle stiffness.

HIWIN recommends the maximum lengths shown in Table 4.10.

If a longer length is required, please contact with HIWIN engineer.

Table 4.10 General manufacturing range of HIWIN screw spindle vs. diameter and accuracy grade

Unit : mm

Total length Grade	O.D.																		
		6	8	10	12	16	20	25	28	32	36	40	45	50	55	63	70	80	100
C0		110	170	300	400	600	700	1000	1000	1200	1300	1500	1600	1800	2000	2000	2000	2000	2000
C1		110	170	400	500	720	950	1300	1500	1800	1800	2300	2500	3100	3500	4000	4000	4000	4000
C2		140	200	500	630	900	1300	1700	1800	2200	2200	2900	3200	4000	5000	5200	5500	6300	6300
C3		170	250	500	630	1000	1400	1800	2000	2500	3200	3500	4000	4500	5000	6000	7100	10000	10000
C4		170	250	500	630	1000	1400	1800	2000	2500	3200	3500	4000	4500	5000	6000	7100	10000	10000
C5		170	250	500	630	1410	1700	2400	2500	3000	3200	3800	4000	5000	5500	6900	7100	10000	10000
C6		400	800	1000	1200	1500	1800	2500	3000	3000	4000	4000	4000	5600	5600	6900	7100	10000	10000
C7		400	800	1000	1200	3000	3000	4000	4000	4500	4500	5600	5600	5600	5600	6900	7100	10000	10000

■ Please consult with HIWIN in this area

## Heat treatment

HIWIN's homogenous heat treatment technique gives the ballscrew maximum life capability. Table 4.11 shows the hardness value of hardness in each component of HIWIN ballscrews. The surface hardness of the ballscrew affects both dynamic and static load value. The dynamic and static values shown in the dimension table are the values for a surface hardness equal to HRC 60. If the surface hardness is lower than this value, the following formula will give you the calibration result.

$$C'o = Co \times f_{HO} \quad f_{HO} = \left( \frac{\text{Real Hardness (HRC)}}{60} \right)^3 \leq 1 \quad \dots\dots\dots \text{M42}$$

$$C' = C \times f_H \quad f_H = \left( \frac{\text{Real Hardness (HRC)}}{60} \right)^2 \leq 1 \quad \dots\dots\dots \text{M43}$$

Where  $f_H$  and  $f_{HO}$  are the hardness factor.

$C'o$  : Calibrated static load

$Co$  : Static load

$C'$  : Calibrated dynamic load

$C$  : Dynamic load

Table 4.11 Hardness of each component of HIWIN ballscrew

Item	Treat Method	Hardness (HRC)
Spindle	Carburizing or Induction Hardening	58 - 62
Nut	Carburizing	58 - 62
Ball		62 - 66

## 4.6 Temperature Rise Effect on Ballscrews

The temperature rise of ballscrew during the working period will influence the accuracy of the machine feed system, especially in a machine designed for high speed and high accuracy.

The following factors have the effect of raising the temperature in a ballscrew.

- (1) Preload (2) Lubrication (3) Pretension

Fig 4.29 shows the relation of working speed, preload and temperature rise. Fig 4.30 shows the relation of nut temperature rise to preload friction torque. From Fig 4.29, Fig 4.30 and example 4.5-5, doubling the preload of the nut will increase the temperature about 5 degrees, but the stiffness increase only by about 5% (few  $\mu\text{m}$ ).

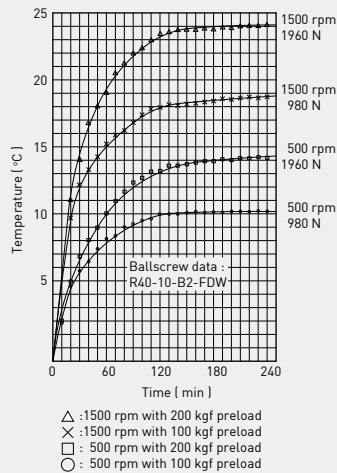

Fig 4.29 The relation of working speed, preload and temperature rise

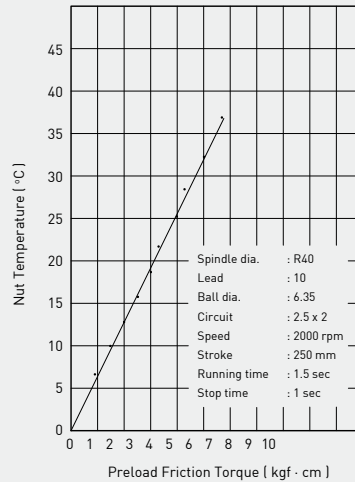

Fig 4.30 The relation of nut temperature rise to preload friction torque

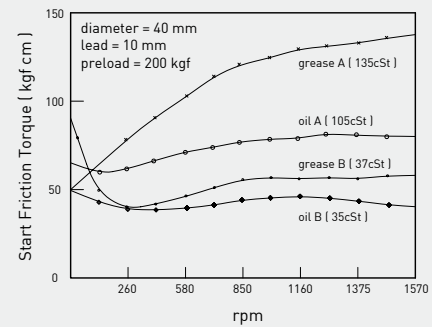

Fig 4.31 The influence of oil viscosity on the friction torque

### (1) Preload effect

To avoid any lost motion in the machine feed system, increasing the rigidity of the ballscrew nut is important. However, to increase the rigidity of the ballscrew nut, it is necessary to preload the nut to a certain level.

Preloading the nut will increase the friction torque of the screw, making it more sensitive to an increase in temperature during working period.

HIWIN recommends using a preload of 8% of the dynamic load for medium and heavy preload, 6% ~ 8% for medium preload, 4% ~ 6% for light and medium and below 4% for light preload.

The heaviest preload should not exceed 10% of the dynamic load for best service life and a low temperature rise effect.

### (2) Lubrication effect

The selection of lubricant will directly influence the temperature rise of the ballscrew.

HIWIN ballscrews require appropriate lubrication either by greasing or oiling. Antifriction bearing oil is recommended for ballscrew oil lubrication. Lithium soap based grease is recommended for ballscrew greasing. The basic oil viscosity requirement depends on the speed, working temperature and load condition of the application. (Fig 4.31) shows the relation of oil viscosity, working speed and rise in temperature.

When the working speed is higher and the working load is lower, a low viscosity oil is better. When the working speed is lower and the working load is heavy, a high viscosity oil is preferred.

Generally speaking, oil with a viscosity of 32 ~ 68 cSt at 40°C (ISO VG 32-68) is recommended for high speed lubrication (DIN 51519) and viscosity above 90 cSt at 40°C (ISO VG 90) is recommended for low speed lubrication.

In high speed and heavy load applications the use of a forced coolant is necessary to lessen the temperature. The forced lubrication of coolant can be done by a hollow ballscrew.

Fig 4.32 shows the comparison of a ballscrew applied with coolant and without coolant. Fig 4.33 shows a typical application for hollow ballscrew in machine tools. The inspection and replenishing of the ballscrew lubricant is listed in Table 4.12.

### (3) Pretension effect

When the temperature rises in the ballscrew, the effect of thermal stress will elongate the screw spindle. It can make the spindle length unstable. ∅

The elongating relationship can be calculated according to M41. This elongation can be compensated via the pretension force. For the purpose of pretension, there is a negative T value indicated in the design drawing to compensate the pretension value.

Since a large pretension force will cause the burn down of the supporting bearing, HIWIN recommends using pretension when the temperature rise is below 5°C. Also, if the diameter of the screw spindle is greater than 50 mm, it is not suitable for pretension. A large spindle diameter requires a high pretension force, causing burn down of the supporting bearing.

HIWIN recommends a T compensation value of about 3°, (about -0.02~0.03 for each 1000 mm screw spindle).

Since different applications require different T values, please contact HIWIN engineer.

The pretension force is calculated as :

$$P_f = K_s \times \Delta L$$

$K_s$  : Stiffness of screw spindle (kgf/μm)

$P_f$  : Pretension force (kgf)

$\Delta L$  : Pretension value (μm)

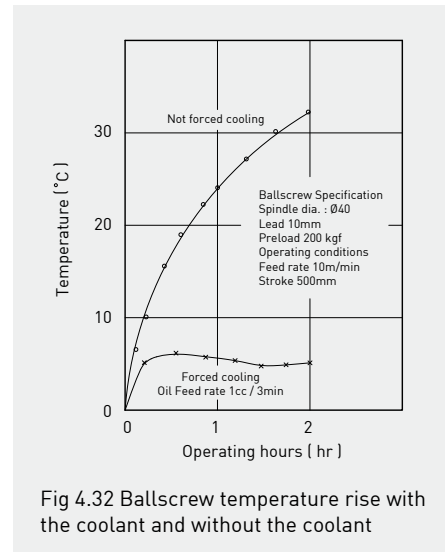

Fig 4.32 Ballscrew temperature rise with the coolant and without the coolant

Table 4.12 : Inspection and replenishment of Lubricant

Lubrication Method	Inspection & Replenishment Guide
Oil	<ul style="list-style-type: none"> <li>• Check the oil level and clean the contamination once a week.</li> <li>• When contamination happens, replacing the oil is recommended.</li> <li>• Lubrication suggestion : Lubrication amount apply onto Ballscrew per 15 minute <math>\frac{\text{Ballscrew outer diameter(mm)}}{56-60}</math> c.c.</li> </ul>
Grease	<ul style="list-style-type: none"> <li>• Inspect for contamination of chips every 2 or 3 months.</li> <li>• If contamination happens, remove old grease and replace with new grease.</li> <li>• Injection amount is about half of internal space within nut every 2 months or 100 km stroke.</li> </ul>

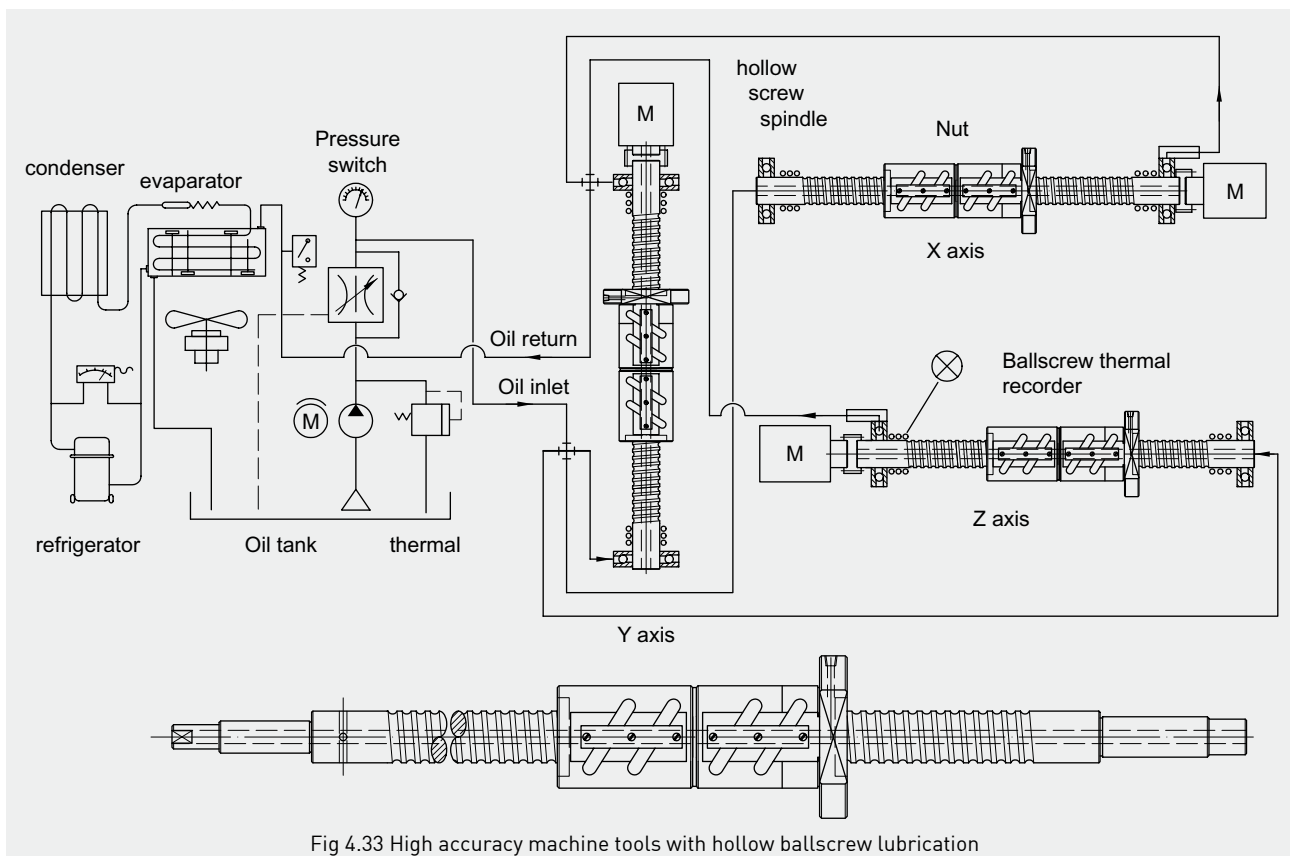

Fig 4.33 High accuracy machine tools with hollow ballscrew lubrication

# 5 Specification Illustration

HIWIN manufactures ballscrews according to customers' blueprints or specifications. Please read the following information for understanding out ballscrew designing.

1. Nominal diameter.
2. Thread lead.
3. Thread length, total length.
4. End journal configuration.
5. Nut configuration
6. Accuracy grade (lead deviation, geometrical tolerance).
7. Working speed.
8. Maximum static load, working load, preload drag torque.
9. Nut safety requirements.
10. Lubrication hole position.

## HIWIN Ballscrew Nomenclature

HIWIN ballscrews can be specified as follows :

**1R40 - 10B2 - PFDWE2 - 800 - 1000 - 0.0035 - M**

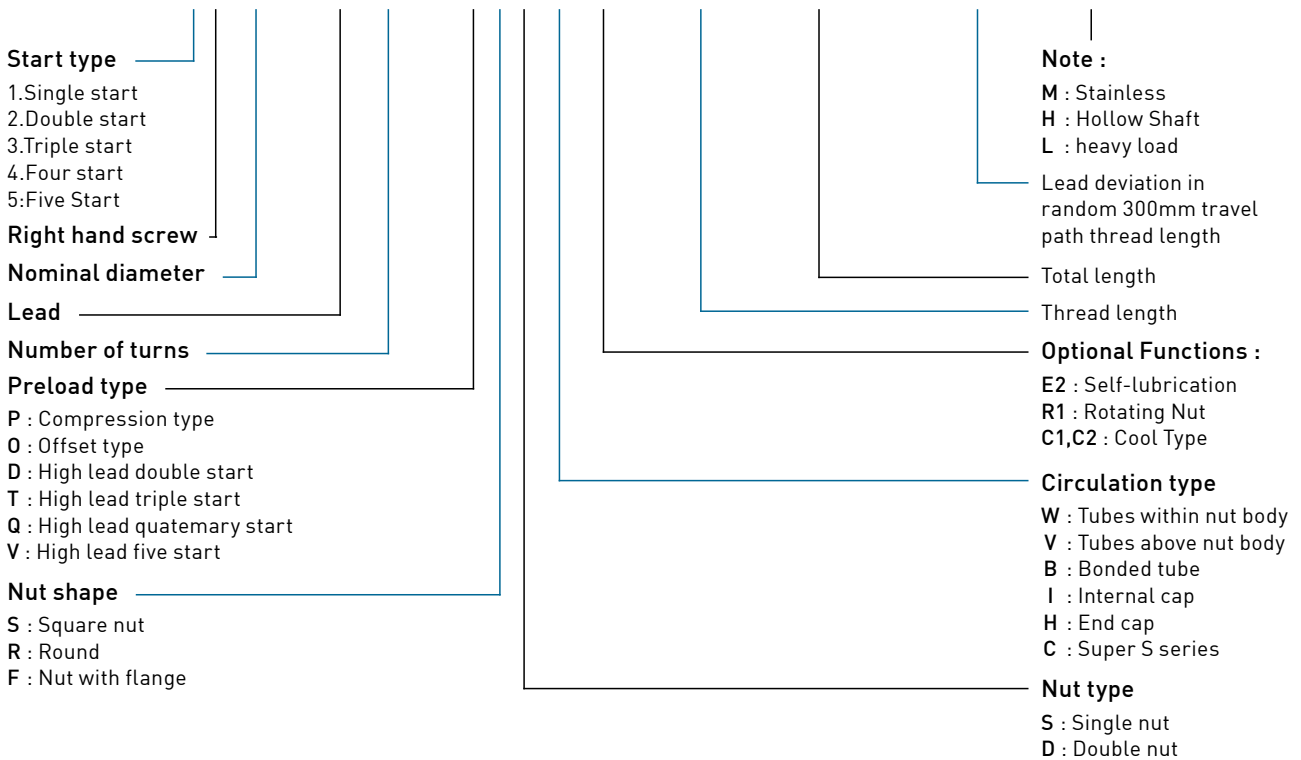

Number of turns

A : 1.5, B: 2.5, C: 3.5	T3 : 3	S1 : 1.8x1	U1 : 2.8x1	K2 : 2
A2 : 1.5x2	T4 : 4	S2 : 1.8x2	U2 : 2.8x2	K3 : 3
B2 : 2.5x2	T5 : 5	S4 : 1.8x4	V2 : 0.8x2	K4 : 4
C1 : 3.5x1	T6 : 6			

- Note :
1. Different diameters and leads are available upon request.
  2. Right hand thread is standard, left hand thread is available upon request.
  3. Longer lengths are available upon request.
  4. Stainless steel is available upon request, only if the ball size is less than 2.381 mm.
  5. Complete questionnaire on page 173~174 and consult with HIWIN engineers.
  6. If you need to order DIN 69051 type, please mark "DIN".
  7. Number of turns = turns per circuit x number of circuits.  
Please refer to page 6 for detailed illustration.



# 6 Precision Ground Ballscrews

## 6.1 Ground Ballscrew Series

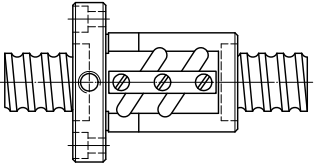
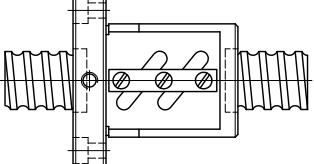
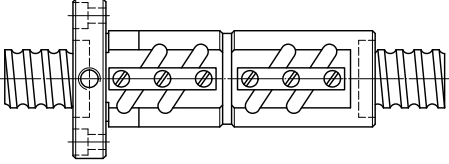
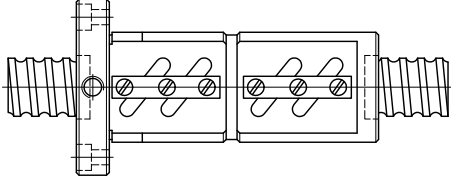
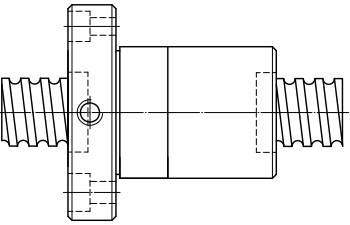
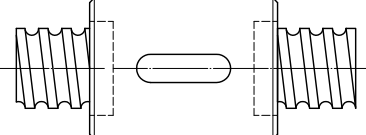
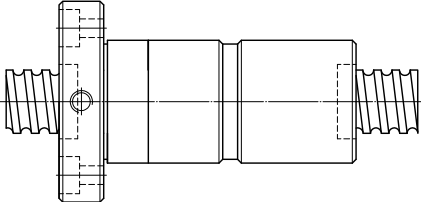
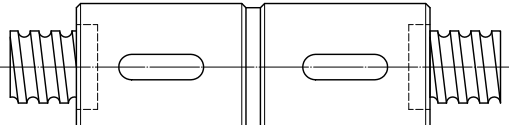
page	General Type		page
<p>39 ? 41</p>	<p>★ ★ <b>FSV</b></p>  <p>Flange end, single nut, tube above the nut diameter</p>	<p>★ ★ <b>FSW</b></p>  <p>Flange end, single nut, tube within the nut diameter</p>	<p>42 ? 44</p>
<p>45 ? 47</p>	<p>★ ★ <b>FDV</b></p>  <p>Flange end, double nut, tube above the nut diameter</p>	<p>★ ★ <b>FDW</b></p>  <p>Flange end, double nut, tube within the nut diameter</p>	<p>48 ? 50</p>
<p>51 ? 53</p>	<p>★ ★ <b>FSI</b></p>  <p>Flange end, single nut, internal recirculation cap</p>	<p><b>RSI</b></p>  <p>Round, single nut, internal recirculation cap</p>	<p>54 ? 55</p>
<p>56 ? 57</p>	<p>★ ★ <b>FDI</b></p>  <p>Flange end, double nut, internal recirculation cap</p>	<p><b>RDI</b></p>  <p>Round, double nut, Internal recirculation cap</p>	<p>58 ? 59</p>

## 6.1 Ground Ballscrew Series

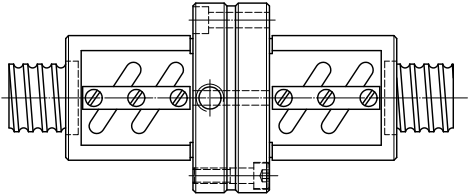
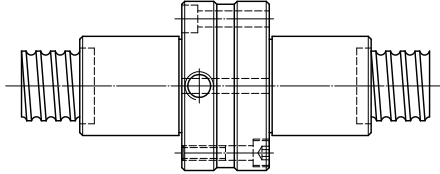
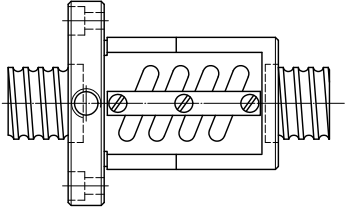
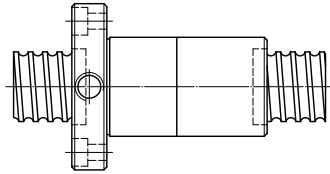
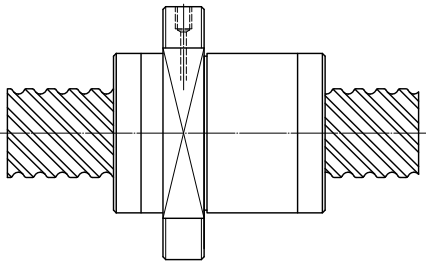
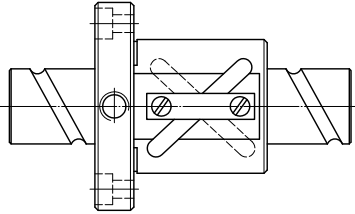
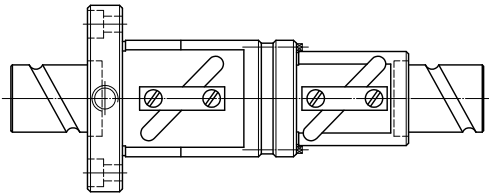
page	General Type		page
60 ? 61	<p>★ ★ <b>PFDW -Type 1</b></p>  <p>Flange to flange, double nut, tube within the nut diameter</p>	<p><b>PFDI</b></p>  <p>Flange to flange, double nut, internal recirculation cap</p>	64 ? 65
66 ? 68	<p>★ ★ <b>OFSW</b></p>  <p>Offset pitch preload, flange end, single nut, tube within the nut diameter</p>	<p>★ ★ <b>OFSI</b></p>  <p>Offset pitch preload, flange end, single nut, internal recirculation cap</p>	69
page	High Lead Type		page
70	<p>★ ★ <b>FSH</b></p>  <p>Large lead, flange mounted, single nut, end cap</p>	<p>★ ★ <b>DFSV</b></p>  <p>Double start, flange end, single nut, tube above the nut diameter</p>	71
62 ? 63	<p>★ ★ <b>PFDW -Type 2</b></p>  <p>Large lead, flange end, compression preload, double nut, tube within nut diameter</p>		62 ? 63

\*Different design required by the drawing approval, please contact with HIWIN engineers for the other type listed above.

\*Double asterisks(★ ★): Self-Lubricating Ballscrew E2 design is available, except the shaft diameter under 16mm or ball diameter under 2.381mm.

## 6.2 Dimension for Precision Ground Ballscrew

### F S V TYPE

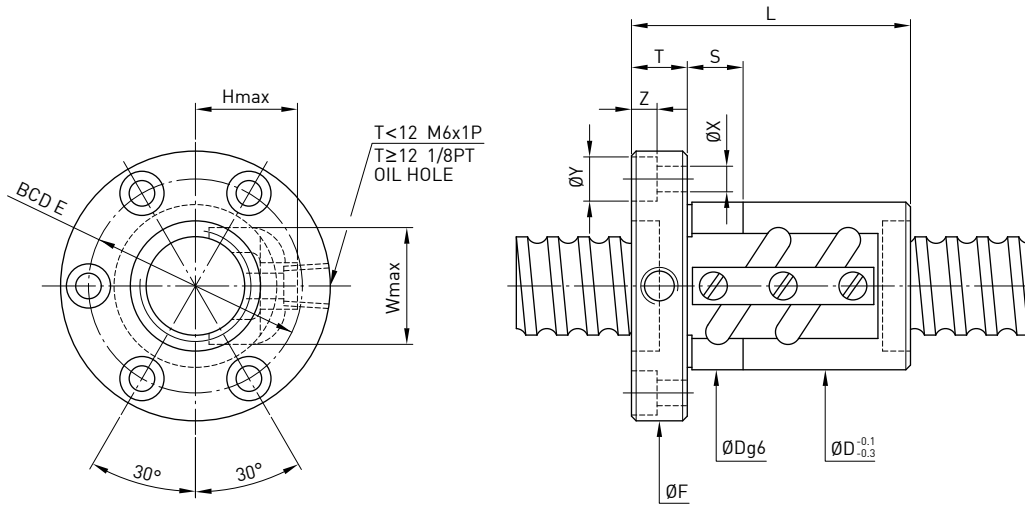

Model	Size		Ball Dia.	PCD	RD	Circuits	Stiffness kgf / $\mu\text{m}$ K	Dynamic Load $1 \times 10^6$ revs C (kgf)	Static Load Co (kgf)	Nut		Flange			Return Tube		Bolt			Fit
	Nominal Dia.	Lead								D	L	F	T	BCD-E	W	H	X	Y	Z	
16-4B2	16	4	2.381	16.25	13.792	2.5x2	26	802	1722	30	48	52	10	40	23	21	5.5	9.5	5.5	12
16-5B1		5	3.175	16.6	13.324	2.5x1	16	763	1400	31	45	54	12	41	27	22	5.5	9.5	5.5	12
16-5B2		5		16.6	13.324	2.5x2	33	1385	2799	31	60	54	12	41	27	22	5.5	9.5	5.5	12
16-5C1		5		16.6	13.324	3.5x1	22	1013	1946	31	50	54	12	41	27	22	5.5	9.5	5.5	12
16-10B1		10		16.6	13.324	2.5x1	16	763	1399	30	54	53	10	41	22.5	23	5.5	9.5	5.5	12
20-5B1	20	5		3.969	20.6	17.324	2.5x1	19	837	1733	35	45	58	12	46	27	25	5.5	9.5	5.5
20-5B2		5	20.6		17.324	2.5x2	39	1519	3465	35	60	58	12	46	27	25	5.5	9.5	5.5	12
20-6B1		6	20.8		16.744	2.5x1	20	1139	2187	36	48	60	12	47	28	27	5.5	9.5	5.5	12
20-6C1		6	20.8		16.744	3.5x1	28	1512	3041	36	66	60	12	47	28	27	5.5	9.5	5.5	12
20-20A1		20	20.8		16.744	1.5x1	13	719	1281	36	66	60	12	47	28	27	5.5	9.5	5.5	12
25-5B2	25	5	3.175	25.6	22.324	3.5x1	35	1252	3085	40	50	64	12	52	31	26	5.5	9.5	5.5	12
25-5C1		5	25.6	22.324	2.5x2	46	1704	4417	40	60	64	12	52	31	26	5.5	9.5	5.5	12	
25-6B2		6	3.969	25.8	21.744	2.5x2	48	2308	5523	42	68	68	12	55	32	28	6.6	11	6.5	12
25-6C1		6	25.8	21.744	3.5x1	35	1690	3844	42	55	68	12	55	32	28	6.6	11	6.5	12	
25-8B2		8	26	21.132	2.5x2	46	2888	6472	50	80	74	13	62	35	31	5.5	9.5	5.5	15	
25-10B1	25	10	4.763	26	21.132	2.5x1	25	1592	3237	45	65	72	16	58	34	29	6.6	11	6.5	12
25-10B2		10		26	21.132	2.5x2	46	2888	6472	47	97	74	15	60	35	31	6.6	11	6.5	15
25-16B1		16		26	21.132	2.5x1	28	1592	3237	45	84	72	16	58	34	29	6.6	11	6.5	12
25-20B1		20		26	21.132	2.5x1	28	1592	3237	45	96	72	16	58	34	30	6.6	11	6.5	12
25-25A1		25		26	21.132	1.5x1	16	1019	1927	45	90	72	16	58	34	30	6.6	11	6.5	12
28-5B1	28	5	3.175	28.6	25.324	2.5x1	26	984	2466	44	45	70	12	56	34	28	6.6	11	6.5	12
28-5B2		5		28.6	25.324	2.5x2	50	1785	4932	44	60	70	12	56	34	28	6.6	11	6.5	12
28-6A2		6		28.6	25.324	1.5x2	29	1150	2960	44	55	70	12	56	34	28	6.6	11	6.5	12
28-6B2		6		28.6	25.324	2.5x2	48	1784	4932	50	61	74	12	60	36	29	6.6	11	6.5	15
32-5B2		32		5	3.969	32.6	29.324	2.5x2	55	1886	5666	50	60	76	12	63	38	30	6.6	11
32-5C1	5		32.6	29.324		3.5x1	39	1388	3967	50	50	76	12	63	38	30	6.6	11	6.5	12
32-6B2	6		32.8	28.744		2.5x2	56	2556	7020	52	68	78	12	65	39	32	6.6	11	6.5	12
32-6C1	6		32.8	28.744		3.5x1	39	1888	4936	52	55	78	12	65	39	32	6.6	11	6.5	12
32-8B2	8		33	28.132		2.5x2	59	3284	8453	54	86	88	16	70	40	33	9	14	8.5	15
32-8C1	32	8	4.763	33	28.132	3.5x1	41	2428	5948	54	70	88	16	70	40	33	9	14	8.5	15
32-10B1		10		33.4	26.91	2.5x1	30	2650	5599	54	70	88	16	70	44	37	9	14	8.5	15
32-10B2		10		33.4	26.91	2.5x2	60	4810	11199	57	98	91	16	73	44	37	9	14	8.5	15
32-10C1		10		33.4	26.91	3.5x1	44	3519	7785	57	78	91	16	73	44	37	9	14	8.5	15
32-16B1		16		33.4	26.91	2.5x1	30	2650	5599	54	100	88	16	70	45	38	9	14	8.5	15
32-20B1	20	33	28.132	2.5x1	33	1810	4227	54	100	88	16	70	40	33	9	14	8.5	15		
32-25B1	25	33	28.132	2.5x1	33	1810	4227	54	118	88	16	70	40	33	9	14	8.5	15		
32-32A1	32	33	28.132	1.5x1	18	1154	2505	54	110	88	16	70	40	33	9	14	8.5	15		
36-6B1	36	6	3.969	36.8	32.744	2.5x1	35	1486	3969	55	50	82	12	68	42	32	6.6	11	6.5	12
36-6B2				36.8	32.744	2.5x2	60	2696	7937	55	68	82	12	68	42	32	6.6	11	6.5	12

Remark: Stiffness values listed above value are derived from theoretical formula while axial load is 30% of dynamic load rating without preload.

**F S V TYPE**

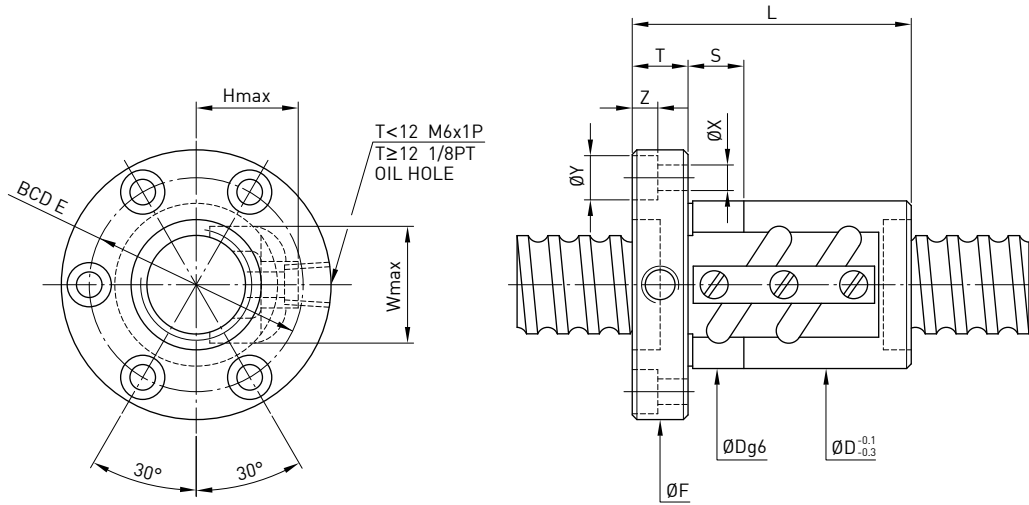

Model	Size		Ball Dia.	PCD	RD	Circuits	Stiffness kgf / μm K	Dynamic Load 1x10 <sup>6</sup> revs C (kgf)	Static Load Co (kgf)	Nut		Flange			Return Tube		Bolt			Fit
	Nominal Dia.	Lead								D	L	F	T	BCD-E	W	H	X	Y	Z	
36-10B2	36	10	6.350	37.4	30.91	2.5x2	68	5105	12669	62	102	104	18	82	49	40	11	17.5	11	15
40-5B2	40	5	3.175	40.6	37.324	2.5x2	66	2071	7134	58	65	92	16	72	46	34	9	14	8.5	15
40-6B2		6	3.969	40.8	36.744	2.5x2	69	2817	8855	60	72	94	16	76	47	36	9	14	8.5	15
40-8B2		8	4.763	41	36.132	2.5x2	70	3634	10603	62	86	96	16	78	48	38	9	14	8.5	15
40-8C1				41	36.132	3.5x1	49	2679	7438	62	70	96	16	78	48	38	9	14	8.5	15
40-10B2		10	6.350	41.4	34.91	2.5x2	74	5370	14138	65	102	106	18	85	52	42	11	17.5	11	15
40-10C1				41.4	34.91	3.5x1	51	3932	9841	65	82	106	18	85	52	42	11	17.5	11	15
40-12B2		12	7.144	41.6	34.299	2.5x2	72	6216	15674	64	108	112	18	88	53	42	11	17.5	11	30
40-16B2				41.6	34.299	2.5x2	72	6216	15674	74	135	110	18	90	52	49	11	17.5	11	30
40-25B1		25		41.4	34.91	2.5x1	39	2959	7069	65	123	106	18	85	52	42	11	17.5	11	15
40-32B1		32		41.4	34.91	2.5x1	39	2959	7069	65	146	106	18	85	52	42	11	17.5	11	15
40-40A1	40	6.350	41.4	34.91	1.5x1	24	1875	4159	65	133	106	18	85	52	42	11	17.5	11	15	
45-10B1	45	10	46.4	39.91	2.5x1	45	4170	11161	70	74	112	18	90	58	48	11	17.5	11	15	
45-10B2			46.4	39.91	2.5x2	79	5655	15905	70	104	112	18	90	58	48	11	17.5	11	15	
45-12B2		12	7.938	46.8	38.688	2.5x2	81	7627	19799	74	123	122	22	97	60	49	13	20	13	20
50-5A2	50	5	50.6	47.324	1.5x2	48	1447	5382	70	63	104	16	86	56	40	9	14	8.5	15	
50-5A3			50.6	47.324	1.5x3	73	2051	8072	70	73	104	16	86	56	40	9	14	8.5	15	
50-6B2		6	3.969	50.8	46.744	2.5x2	81	3093	11149	72	75	106	16	88	57	43	9	14	8.5	15
50-6B3				50.8	46.744	2.5x3	119	4384	16723	72	93	106	16	88	57	43	9	14	8.5	15
50-8B2		8	4.763	51	46.132	2.5x2	84	4004	13409	75	88	116	18	95	58	45	11	17.5	11	15
50-8B3				51	46.132	2.5x3	124	5674	20114	75	112	116	18	95	58	45	11	17.5	11	15
50-10B2		10	6.350	51.4	44.91	2.5x2	87	5923	17670	78	104	119	18	98	62	48	11	17.5	11	15
50-10B3				51.4	44.91	2.5x3	129	8394	26505	78	134	119	18	98	62	48	11	17.5	11	15
50-10C1				51.4	44.91	3.5x1	60	4393	12481	78	84	119	18	98	62	48	11	17.5	11	15
50-12B1				12	7.938	51.8	43.688	2.5x1	46	4420	11047	82	87	130	22	105	64	52	13	20
50-12B2	51.8	43.688	2.5x2			90	8022	22094	82	123	130	22	105	64	52	13	20	13	20	
50-12C1	12	7.938	51.8	43.688	3.5x1	63	5875	15380	82	99	130	22	105	64	52	13	20	13	20	
50-40A1	40		51.8	43.688	1.5x1	27	2801	6499	82	135	130	22	105	64	52	13	20	13	20	
50-50A1	50		51.8	43.688	1.5x1	30	2801	6499	82	162	130	22	105	64	52	13	20	13	20	
55-10C1	55	10	6.350	56.4	49.91	3.5x1	66	4562	13661	84	84	125	18	103	68	54	11	17.5	11	20
55-12B2		12	7.938	56.8	48.688	2.5x2	95	8392	24390	88	123	136	22	110	70	56	13	20	13	20
55-20B2		20	12.700	58	45.16	2.5x2	127	20160	52439	100	175	132	28	115	74	71	9	14	8.5	30
63-8A2	63	8	4.763	64	59.132	1.5x2	54	2826	10129	87	76	129	18	107	70	50	11	17.5	11	20
63-8A3				64	59.132	1.5x3	80	4004	15193	87	92	129	18	107	70	50	11	17.5	11	20
63-10B2		10	6.350	64.4	57.91	2.5x2	104	6533	22371	90	107	132	20	110	74	53	11	17.5	11	20
63-10B3				64.4	57.91	2.5x3	154	9258	33556	90	137	132	20	110	74	53	11	17.5	11	20
63-12B2	12	7.938	64.8	56.688	2.5x2	109	8943	28062	94	124	142	22	117	76	57	13	20	13	20	
63-16B2	16		65.2	55.466	2.5x2	141	14862	46009	100	153	150	22	123	78	62	13	20	13	20	
63-20B2	20		65.2	55.466	2.5x2	141	14862	46009	100	176	150	22	123	78	62	13	20	13	20	

Remark: Stiffness values listed above value are derived from theoretical formula while axial load is 30% of dynamic load rating without preload.

**F S V TYPE**

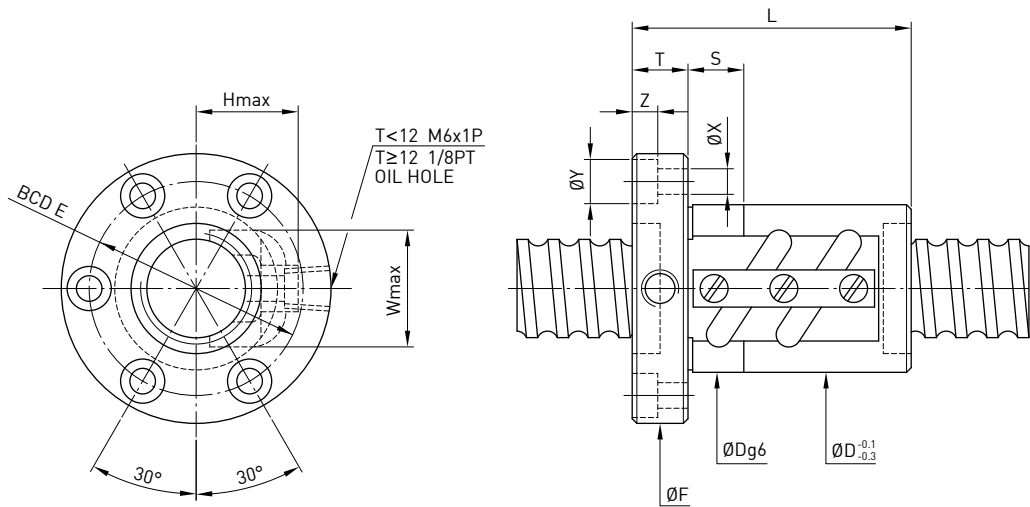

Model	Size		Ball Dia.	PCD	RD	Circuits	Stiffness kgf / $\mu\text{m}$ K	Dynamic Load $1 \times 10^6$ revs C (kgf)	Static Load Co (kgf)	Nut		Flange			Return Tube		Bolt			Fit			
	Nominal Dia.	Lead								D	L	F	T	BCD-E	W	H	X	Y	Z		S		
63-20B3	63	20	12.700	66	53.16	2.5x3	210	30715	90887	117	244	157	32	137	82	70	11	17.5	11	30			
70-10B2	70	10	6.350	71.4	64.91	2.5x2	115	6843	25011	104	109	152	20	128	80	56	13	20	13	20			
70-10B3				71.4	64.91	2.5x3	170	9688	37516	104	139	152	20	128	80	56	13	20	13	20			
70-12B2		12	7.938	71.8	63.688	2.5x2	120	9382	31275	110	125	159	22	133	82	58	13	20	13	20			
70-12B3				71.8	63.688	2.5x3	170	13296	46912	110	159	159	22	133	82	58	13	20	13	20			
80-10B2	80	10	6.350	81.4	74.91	2.5x2	126	7202	28538	115	109	163	22	137	90	64	13	20	13	20			
80-10B3				81.4	74.91	2.5x3	186	10207	42807	115	139	163	22	137	90	64	13	20	13	20			
80-12B2		12	7.938	81.8	73.688	2.5x2	130	9797	35422	120	125	169	22	143	92	67	13	20	13	25			
80-12B3				81.8	73.688	2.5x3	192	13884	53132	120	159	169	22	143	92	67	13	20	13	25			
80-16B2		16	9.525	82.2	82.2	72.466	2.5x2	171	16485	58851	125	156	190	28	154	94	70	18	26	17.5	25		
80-16B3					82.2	72.466	2.5x3	252	23363	88276	125	204	190	28	154	94	70	18	26	17.5	25		
80-20B2					20	82.2	82.2	72.466	2.5x2	171	16485	58851	125	185	190	28	154	94	70	18	26	17.5	25
80-20B3							82.2	72.466	2.5x3	252	23363	88276	125	245	190	28	154	94	70	18	26	17.5	25
100-12B2		100	12	7.938	101.8	93.688	2.5x2	156	10761	44586	145	132	209	28	173	112	76	18	26	17.5	25		
100-12B3					101.8	93.688	2.5x3	229	15251	66894	145	168	209	28	173	112	76	18	26	17.5	25		
100-16B2	16		9.525	102.2	102.2	92.466	2.5x2	200	18123	74425	150	162	228	32	185	114	80	22	32	21.5	30		
100-16B3					102.2	92.466	2.5x3	305	25684	111637	150	212	228	32	185	114	80	22	32	21.5	30		
100-20B2					20	102.2	102.2	92.466	2.5x2	200	18123	74425	150	190	228	32	185	114	80	22	32	21.5	30
100-20B3							102.2	92.466	2.5x3	305	25684	111637	150	250	228	32	185	114	80	22	32	21.5	30

Remark: Stiffness values listed above value are derived from theoretical formula while axial load is 30% of dynamic load rating without preload.

**F S W TYPE**

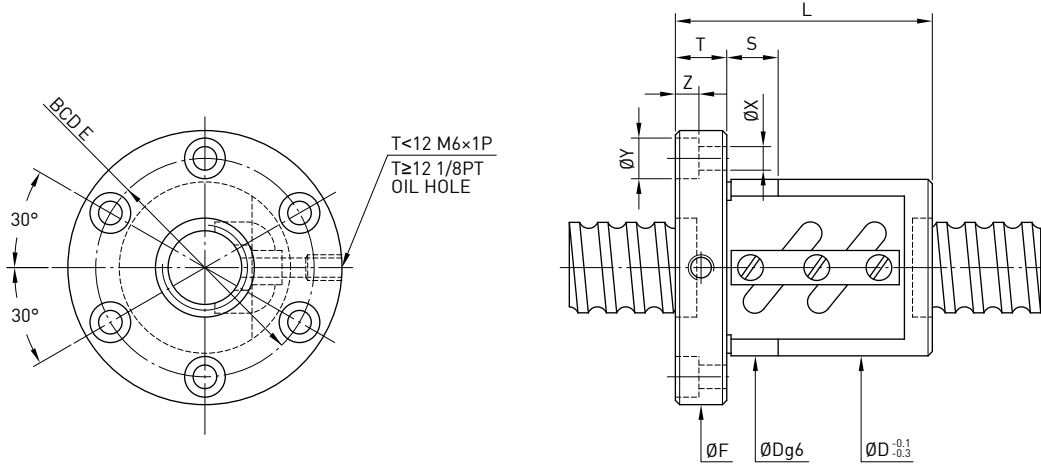

Model	Size		Ball Dia.	PCD	RD	Circuits	Stiffness kgf / $\mu\text{m}$ K	Dynamic Load $1 \times 10^6$ revs C (kgf)	Static Load Co (kgf)	Nut		Flange			Bolt			Fit		
	Nominal Dia.	Lead								D	L	F	T	BCD-E	X	Y	Z		S	
12-4B1	12	4	2.381	12.25	9.792	2.5x1	8	383	638	30	38	50	10	40	4.5	8	4	12		
12-4C1				12.25	9.792	3.5x1	9	511	893	30	44	50	10	40	4.5	8	4	12		
12-5B1				12.25	9.792	2.5x1	8	383	638	30	40	50	10	40	4.5	8	4	12		
14-5B1	14	5		14.6	11.324	2.5x1	10	710	1216	34	40	57	11	45	5.5	9.5	5.5	12		
15-10A1	15	10	3.175	15.6	12.324	1.5x1	9	474	781	34	48	57	11	45	5.5	9.5	5.5	12		
15-20A1		20		15.6	12.324	1.5x1	9	474	781	34	62	58	12	45	5.5	9.5	9.5	12		
16-4B1	16	4	2.381	16.25	13.792	2.5x1	14	439	870	34	38	57	11	45	5.5	9.5	5.5	12		
16-5B1				5	3.175	16.6	13.324	2.5x1	16	763	1400	40	45	64	12	51	5.5	9.5	5.5	12
16-5B2						16.6	13.324	2.5x2	33	1385	2799	40	60	64	12	51	5.5	9.5	5.5	12
16-5C1	5	3.175	16.6	13.324	3.5x1	22	1013	1946	40	50	64	12	51	5.5	9.5	5.5	12			
20-5B1	20	5	3.175	20.6	17.324	2.5x1	19	837	1733	44	45	68	12	55	5.5	9.5	5.5	12		
20-5B2				20.6	17.324	2.5x2	39	1519	3465	44	60	68	12	55	5.5	9.5	5.5	12		
20-6B1				6	3.969	20.8	16.744	2.5x1	20	1137	2187	48	48	72	12	59	5.5	9.5	5.5	12
20-6C1	20.8	16.744	3.5x1			28	1512	3041	48	66	72	12	59	5.5	9.5	5.5	12			
25-4B2	25	4	2.381	25.25	22.792	2.5x2	38	976	2776	46	48	69	11	57	5.5	9.5	5.5	12		
25-5B2				5	3.175	25.6	22.324	2.5x2	46	1704	4417	50	60	74	12	62	5.5	9.5	5.5	12
25-5C1						25.6	22.324	3.5x1	35	1252	3085	50	50	74	12	62	5.5	9.5	5.5	12
25-6B1	6	3.969	3.175	25.8	21.744	2.5x1	24	1255	2735	53	44	76	11	64	5.5	9.5	5.5	12		
25-6B2				25.8	21.744	2.5x2	48	2308	5523	56	68	82	12	69	6.6	11	6.5	12		
25-6C1				25.8	21.744	3.5x1	35	1690	3844	56	55	82	12	69	6.6	11	6.5	12		
25-10B1	10	4.763	3.175	26	21.132	2.5x1	25	1592	3237	60	65	86	16	73	6.6	11	6.5	12		
25-10B2				26	21.132	2.5x2	46	2888	6472	58	97	85	15	71	6.6	11	6.5	12		
25-12B1				12	3.969	25.8	21.744	2.5x1	24	1271	2761	53	60	78	11	64	6.6	11	6.5	12
28-5B1	28	5	3.175	28.6	25.324	2.5x1	26	984	2466	55	45	85	12	69	6.6	11	6.5	12		
28-5B2				6	3.969	28.6	25.324	2.5x2	50	1785	4932	55	60	85	12	69	6.6	11	6.5	12
28-6A2						28.6	25.324	1.5x2	29	1150	2960	55	55	85	12	69	6.6	11	6.5	12
28-12B2	12	4.763	29	24.132	2.5x2	51	3060	7299	60	110	86	12	73	6.6	11	6.5	12			
28-16B1	16	4.763	29	24.132	2.5x1	25	1686	3649	62	84	89	12	75	6.6	11	6.5	12			
32-5B2	32	5	3.175	32.6	29.324	2.5x2	55	1886	5666	58	60	84	12	71	6.6	11	6.5	12		
32-5C1				32.6	29.324	3.5x1	39	1388	3967	58	50	84	12	71	6.6	11	6.5	12		
32-6B2				6	3.969	32.8	28.744	2.5x2	56	2556	7020	62	68	88	12	75	6.6	11	6.5	12
32-6C1	32.8	28.744	3.5x1			39	1888	4936	62	55	88	12	75	6.6	11	6.5	12			
32-8B2	8	4.763	3.175	33	28.132	2.5x2	59	3284	8453	66	86	100	16	82	9	14	8.5	15		
32-8C1				33	28.132	3.5x1	41	2428	5948	66	70	100	16	82	9	14	8.5	15		
32-10B2				10	6.350	33.4	26.91	2.5x2	60	4810	11199	74	98	108	16	90	9	14	8.5	15
32-10C1	33.4	26.91	3.5x1			44	3519	7785	74	78	108	16	90	9	14	8.5	15			
32-12A2	12	6.350	3.175	33.4	26.91	1.5x2	37	3051	6612	74	97	108	18	90	9	14	8.5	15		
32-12B2				33.4	26.91	2.5x2	59	4810	11199	74	110	108	18	90	9	14	8.5	15		

Remark: Stiffness values listed above value are derived from theoretical formula while axial load is 30% of dynamic load rating without preload.

**F S W TYPE**

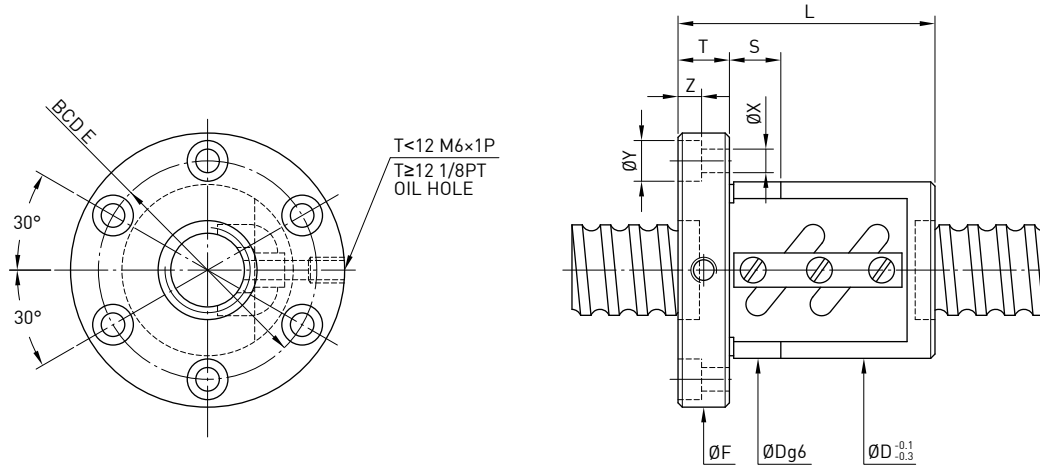

Model	Size		Ball Dia.	PCD	RD	Circuits	Stiffness kgf / $\mu\text{m}$ K	Dynamic Load $1 \times 10^6$ revs C (kgf)	Static Load Co (kgf)	Nut		Flange			Bolt			Fit	
	Nominal Dia.	Lead								D	L	F	T	BCD-E	X	Y	Z		S
32-16A2	32	16	6.350	33.4	26.91	1.5x2	36	3035	6555	74	99	108	16	90	9	14	8.5	15	
32-16B1				33.4	26.91	2.5x1	30	2650	5599	74	94	108	16	90	9	14	8.5	15	
32-16B2		33.4		26.91	2.5x2	59	4810	11199	74	130	108	16	90	9	14	8.5	15		
32-20A2		20		33.4	26.91	1.5x2	37	3035	6555	74	120	108	16	90	9	14	8.5	15	
32-20B1				33.4	26.91	2.5x1	30	2650	5599	74	98	108	16	90	9	14	8.5	15	
36-6B1	36	6	3.969	36.8	32.744	2.5x1	35	1486	3969	65	50	100	12	82	6.6	11	6.5	12	
36-6B2				36.8	32.744	2.5x2	60	2696	7937	65	68	100	12	82	6.6	11	6.5	12	
36-10B2		10		37.4	30.91	2.5x2	68	5105	12669	75	102	125	18	98	11	17.5	11	15	
36-12B2				37.4	30.91	2.5x2	65	5105	12668	75	110	125	18	98	11	17.5	11	15	
36-16C1				16	37.4	30.91	3.5x1	46	3736	8813	80	105	120	18	100	11	17.5	11	15
40-5B2	40	5	3.175	40.6	37.324	2.5x2	66	2071	7134	68	65	102	16	84	9	14	8.5	15	
40-6B2		6	3.969	40.8	36.744	2.5x2	69	2817	8855	70	72	104	16	86	9	14	8.5	15	
40-8B2		8	4.763	41	36.132	2.5x2	70	3634	10603	74	86	108	16	90	9	14	8.5	15	
40-8C1				41	36.132	3.5x1	49	2679	7438	74	70	108	16	90	9	14	8.5	15	
40-10B2		10	6.350	41.4	34.91	2.5x2	74	5370	14138	84	102	125	18	104	11	17.5	11	15	
40-10C1				41.4	34.91	3.5x1	51	3932	9841	84	82	125	18	104	11	17.5	11	15	
40-12B1				12	7.144	41.6	34.299	2.5x1	36	3425	7837	86	81	128	18	106	11	17.5	11
40-12B2		41.6	34.299			2.5x2	72	6217	15674	86	117	128	18	106	11	17.5	11	20	
40-16A2		16	7.144	41.6	34.299	1.5x2	42	4007	9405	86	118	128	18	106	11	17.5	11	20	
40-16B1				41.6	34.299	2.5x1	37	3425	7837	86	102	128	18	106	11	17.5	11	20	
45-10B1	45	10	6.350	46.4	39.91	2.5x1	45	3116	7953	88	74	132	18	110	11	17.5	11	15	
45-10B2				46.4	39.91	2.5x2	79	5655	15905	88	104	132	18	110	11	17.5	11	15	
45-12B2		12		7.938	46.8	38.688	2.5x2	81	7627	19799	96	123	142	22	117	13	20	13	20
50-5A2	50	5	3.175	50.6	47.324	1.5x2	48	1447	5382	80	63	114	16	96	9	14	8.5	15	
50-5A3				50.6	47.324	1.5x3	73	2051	8072	80	73	114	16	96	9	14	8.5	15	
50-6B2		6		3.969	50.8	46.744	2.5x2	81	3093	11149	84	75	118	16	100	9	14	8.5	15
50-6C2					50.8	46.744	3.5x2	109	4131	15608	84	80	118	15	100	9	14	8.5	15
50-6B3					50.8	46.744	2.5x3	119	4384	16723	84	93	118	16	100	9	14	8.5	15
50-8B2		8	4.763	51	46.132	2.5x2	84	4004	13409	87	88	128	18	107	11	17.5	11	15	
50-8B3				51	46.132	2.5x3	124	5674	20114	87	112	128	18	107	11	17.5	11	15	
50-10B2		10	6.350	51.4	44.91	2.5x2	87	5923	17670	94	104	135	18	114	11	17.5	11	15	
50-10B3				51.4	44.91	2.5x3	129	8394	26505	94	134	135	18	114	11	17.5	11	15	
50-10C1				51.4	44.91	3.5x1	60	4393	12481	94	84	135	18	114	11	17.5	11	15	
50-12B1	12	7.938	51.8	43.688	2.5x1	46	4420	11047	102	87	150	22	125	13	20	13	20		
50-12B2			51.8	43.688	2.5x2	90	8022	22094	102	123	150	22	125	13	20	13	20		
50-12C1			51.8	43.688	3.5x1	63	5875	15380	102	99	150	22	125	13	20	13	20		
50-30A2	30	6.350	51.4	44.91	1.5x2	52	3834	10658	94	160	135	18	114	11	17.5	11	15		

Remark : Stiffness values listed above value are derived from theoretical formula while axial load is 30% of dynamic load rating without preload.

**F S W TYPE**

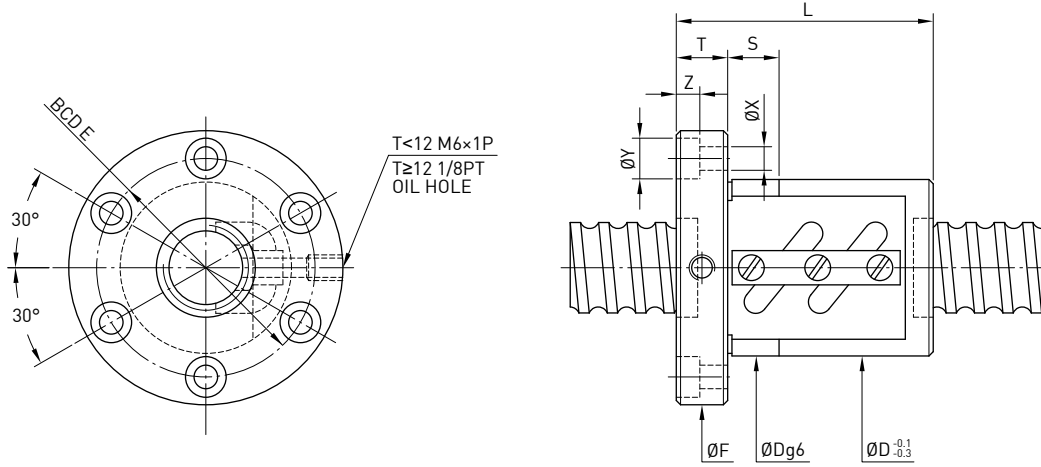

Model	Size		Ball Dia.	PCD	RD	Circuits	Stiffness kgf / $\mu$ m K	Dynamic Load $1 \times 10^6$ revs C (kgf)	Static Load Co (kgf)	Nut		Flange			Bolt			Fit	
	Nominal Dia.	Lead								D	L	F	T	BCD-E	X	Y	Z		S
55-10B2	55	10	6.350	56.4	49.91	2.5x2	93	6071	19592	102	103	144	18	122	11	17.5	11	20	
55-10C1				56.4	49.91	3.5x1	66	4562	13661	100	84	140	18	118	11	17.5	11	20	
55-12B2				56.8	48.688	2.5x2	95	8392	24390	105	123	154	22	127	13	20	13	20	
60-12B2	60	12	7.938	61.8	53.688	2.5x2	101	8742	26685	112	135	154	18	132	11	17.5	11	20	
63-8A2				63	8	64	59.132	1.5x2	54	2826	10129	104	76	146	18	124	11	17.5	11
63-8A3	64	59.132	1.5x3			80	4004	15193	104	92	146	18	124	11	17.5	11	20		
63-10B2	10	6.350	64.4			57.91	2.5x2	104	6533	22371	110	107	152	20	130	11	17.5	11	20
63-10B3			64.4	57.91	2.5x3	154	9528	33556	110	137	152	20	130	11	17.5	11	20		
63-12B2			12	7.938	64.8	56.688	2.5x2	109	8943	28062	118	124	166	22	141	13	20	13	20
63-16B2	16	9.525			65.2	55.466	2.5x2	141	14862	46009	124	153	172	22	147	13	20	13	20
63-20B2					65.2	55.466	2.5x2	141	14862	46009	124	176	172	22	147	13	20	13	20
70-10B2			70	10	6.350	71.4	64.91	2.5x2	115	6843	25011	124	109	170	20	145	13	20	13
70-10B3	71.4	64.91				2.5x3	170	9698	37516	124	139	170	20	145	13	20	13	20	
70-12B2	12	7.938				71.8	63.688	2.5x2	120	9382	31275	130	125	178	22	152	13	20	13
70-12B3			71.8	63.688	2.5x3	170	13296	46912	130	159	178	22	152	13	20	13	20		
80-10B2			80	10	6.350	81.4	74.91	2.5x2	126	7202	28538	130	109	178	22	152	13	20	13
80-10B3	81.4	74.91				2.5x3	186	10207	42807	130	139	178	22	152	13	20	13	20	
80-12B2	12	7.938				81.8	73.688	2.5x2	130	9797	35422	136	125	185	22	159	13	20	13
80-12B3			81.8	73.688	2.5x3	192	13844	53132	136	159	185	22	159	13	20	13	20		
80-16B2			16	9.525	82.2	72.466	2.5x2	171	16485	58851	145	156	210	28	174	18	26	17.5	25
80-16B3	82.2	72.466			2.5x3	252	23363	88276	145	204	210	28	174	18	26	17.5	25		
80-20B2	20	9.525			82.2	72.466	2.5x2	171	16485	58851	145	185	210	28	174	18	26	17.5	25
80-20B3			82.2	72.466	2.5x3	252	23363	88276	145	245	210	28	174	18	26	17.5	25		
100-12B2			100	12	7.938	101.8	93.688	2.5x2	156	10761	44596	160	132	224	24	188	18	26	17.5
100-12B3	101.8	93.688				2.5x3	229	15251	66894	160	168	224	24	188	18	26	17.5	25	
100-16B2	16	9.525				102.2	92.466	2.5x2	200	18123	77425	170	162	248	32	205	22	32	21.5
100-16B3			102.2	92.466	2.5x3	305	25684	111637	170	212	248	32	205	22	32	21.5	30		
100-20B2			20	9.525	102.2	92.466	2.5x2	200	18123	74425	170	190	248	32	205	22	32	21.5	30
100-20B3	102.2	92.466			2.5x3	305	25684	111637	170	250	248	32	205	22	32	21.5	30		

Remark: Stiffness values listed above value are derived from theoretical formula while axial load is 30% of dynamic load rating without preload.



**F D V TYPE**

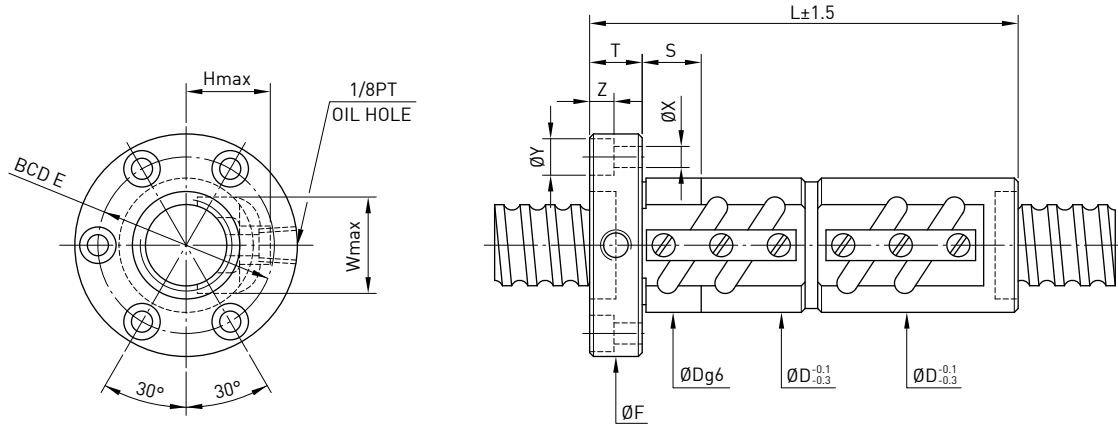

Model	Size		Ball Dia.	PCD	RD	Circuits	Stiffness kgf / $\mu\text{m}$ K	Dynamic Load $1 \times 10^6$ revs C (kgf)	Static Load Co (kgf)	Nut		Flange			Return Tube		Bolt			Fit
	Nominal Dia.	Lead								D	L	F	T	BCD-E	W	H	X	Y	Z	
16-5B1	16	5	3.175	16.6	13.324	2.5x1	32	763	1400	31	80	54	12	41	24	22	5.5	9.5	5.5	24
16-5B2				16.6	13.324	2.5x2	65	1385	2799	31	110	54	12	41	24	22	5.5	9.5	5.5	24
16-5C1				16.6	13.324	3.5x1	46	1013	1946	31	90	54	12	41	24	22	5.5	9.5	5.5	24
20-5B1	20	6	3.969	20.6	17.324	2.5x1	38	837	1733	35	80	58	12	46	27	25	5.5	9.5	5.5	24
20-5B2				20.6	17.324	2.5x2	76	1519	3465	35	110	58	12	46	27	25	5.5	9.5	5.5	24
20-6B1				20.8	16.744	2.5x1	40	1139	2187	36	92	60	12	47	28	27	5.5	9.5	5.5	24
20-6C1	20.8	16.744	3.5x1	55	1512	3041	36	104	60	12	47	28	27	5.5	9.5	5.5	24			
25-5B1	25	5	3.175	25.6	22.324	2.5x1	46	939	2209	40	80	64	12	52	31	26	5.5	9.5	5.5	24
25-5B2				25.6	22.324	2.5x2	90	1704	4417	40	110	64	12	52	31	26	5.5	9.5	5.5	24
25-5C1				25.6	22.324	3.5x1	68	1252	3085	40	90	64	12	52	31	26	5.5	9.5	5.5	24
25-6B2	6	3.969	25.8	21.744	2.5x2	94	2308	5523	42	128	68	12	55	32	28	6.6	11	6.5	24	
25-6C1			25.8	21.744	3.5x1	66	1690	3844	42	104	68	12	55	32	28	6.6	11	6.5	24	
25-10B1			26	21.132	2.5x1	48	1592	3237	45	122	72	16	58	34	29	6.6	11	6.5	24	
28-5B1	28	5	3.175	28.6	25.324	2.5x1	51	984	2466	44	80	70	12	56	34	28	6.6	11	6.5	24
28-5B2				28.6	25.324	2.5x2	98	1785	4932	44	110	70	12	56	34	28	6.6	11	6.5	24
28-6A2				28.6	25.324	1.5x2	59	1150	2960	44	110	70	12	56	34	28	6.6	11	6.5	24
28-8A2	8	4.763	29	24.132	1.5x2	62	1960	4348	50	110	75	12	61	38	32	6.6	11	6.5	15	
28-10B2			29	24.132	2.5x2	102	3060	7299	54	177	94	15	74	37	32	9	14	8.5	30	
32-5B1	32	5	3.175	32.6	29.324	2.5x1	55	1039	2833	50	80	76	12	63	38	30	6.6	11	6.5	24
32-5B2				32.6	29.324	2.5x2	109	1886	5666	50	110	76	12	63	38	30	6.6	11	6.5	24
32-5C1				32.6	29.324	3.5x1	76	1388	3967	50	90	76	12	63	38	30	6.6	11	6.5	24
32-6B1	6	3.969	32.8	28.744	2.5x1	57	1409	3510	52	92	78	12	65	39	32	6.6	11	6.5	24	
32-6B2			32.8	28.744	2.5x2	112	2556	7020	52	128	78	12	65	39	32	6.6	11	6.5	24	
32-6C1			32.8	28.744	3.5x1	78	1888	4936	52	104	78	12	65	39	32	6.6	11	6.5	24	
32-8B1	8	4.763	33	28.132	2.5x1	58	1810	4227	54	110	88	16	70	40	33	9	14	8.5	30	
32-8B2			33	28.132	2.5x2	115	3284	8453	54	158	88	16	70	40	33	9	14	8.5	30	
32-8C1			33	28.132	3.5x1	82	2428	5948	54	126	88	16	70	40	33	9	14	8.5	30	
32-10B1	10	6.350	33.4	26.91	2.5x1	58	2651	5600	57	122	91	16	73	44	37	9	14	8.5	30	
32-10B2			33.4	26.91	2.5x2	118	4810	11199	57	182	91	16	73	44	37	9	14	8.5	30	
32-10C1			33.4	26.91	3.5x1	86	3519	7785	57	142	91	16	73	44	37	9	14	8.5	30	
32-12A2	12	6.350	33.4	26.91	1.5x2	72	3035	6555	62	180	108	16	86	44	38	9	14	8.5	15	
32-12B1			33.4	26.91	2.5x1	62	2650	5599	62	138	108	16	86	44	38	9	14	8.5	20	
32-16A2			33.4	26.91	1.5x2	72	3035	6555	62	180	108	16	86	44	38	9	14	8.5	20	
36-6B1	36	6	3.969	36.8	32.744	2.5x1	62	1486	3969	55	92	82	12	68	42	32	6.6	11	6.5	24
36-6B2				36.8	32.744	2.5x2	121	2696	7937	55	128	82	12	68	42	32	6.6	11	6.5	24
36-10B2				37.4	30.91	2.5x2	132	5105	12669	62	184	104	18	82	49	40	11	17.5	11	30

Remark : Stiffness values listed above are derived from theoretical formula while preload is 10% of dynamic load rating.

**F D V TYPE**

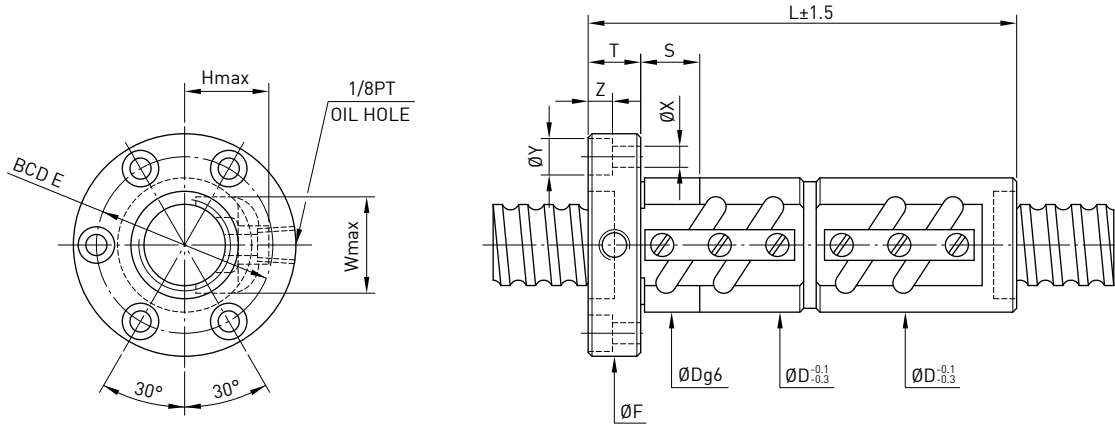

Model	Size		Ball Dia.	PCD	RD	Circuits	Stiffness kgf / $\mu\text{m}$ K	Dynamic Load $1 \times 10^6$ revs C (kgf)	Static Load Co (kgf)	Nut		Flange			Return Tube		Bolt			Fit	
	Nominal Dia.	Lead								D	L	F	T	BCD-E	W	H	X	Y	Z		S
40-5B1	40	5	3.175	40.6	37.324	2.5x1	65	1141	3567	58	84	92	16	72	46	34	9	14	8.5	30	
40-5B2				40.6	37.324	2.5x2	132	2071	7134	58	114	92	16	72	46	34	9	14	8.5	30	
40-6B2		6	3.969	40.8	36.744	2.5x2	136	2817	8855	60	132	94	16	76	47	36	9	14	8.5	30	
40-8B1				41	36.132	2.5x1	69	2003	5302	62	110	96	16	78	48	38	9	14	8.5	30	
40-8B2		8	4.763	41	36.132	2.5x2	137	3634	10603	62	158	96	16	78	48	38	9	14	8.5	30	
40-8C1				41	36.132	3.5x1	96	2679	7438	62	126	96	16	78	48	38	9	14	8.5	30	
40-10B1		10	6.350	41.4	34.91	2.5x1	72	2959	7069	65	132	106	18	85	52	42	11	17.5	11	30	
40-10B2				41.4	34.91	2.5x2	145	5370	14138	65	192	106	18	85	52	42	11	17.5	11	30	
40-10C1		12	6.350	41.4	34.91	3.5x1	102	3932	9841	65	152	106	18	85	52	42	11	17.5	11	30	
40-12A2				41.4	34.91	1.5x2	88	3402	8316	65	160	106	18	84	52	42	11	17.5	11	20	
40-12B1		12	7.144	41.6	34.299	2.5x1	70	3425	7837	70	153	112	18	90	55	43	11	17.5	11	40	
40-12B2				41.6	34.299	2.5x2	141	6217	15674	70	225	112	18	90	55	43	11	17.5	11	40	
40-12C1		16	7.144	41.6	34.299	3.5x1	103	3932	9841	65	158	106	18	85	52	42	11	17.5	11	30	
40-16A2				41.6	34.299	1.5x2	88	4006	9404	75	209	117	18	95	53	43	11	17.5	11	40	
40-16B1		20	7.144	41.6	34.299	2.5x1	118	3425	7837	75	153	117	18	95	53	43	11	17.5	11	40	
40-20A1				41.4	34.91	1.5x1	44	1874	4158	65	152	106	18	85	52	42	11	17.5	11	30	
45-10B1	45	10	6.350	46.4	39.91	2.5x1	76	3116	7953	70	134	112	18	90	58	48	11	17.5	11	30	
45-10B2				46.4	39.91	2.5x2	156	5655	15905	70	194	112	18	90	58	48	11	17.5	11	30	
45-12B2		12	7.938	46.8	38.688	2.5x2	162	7627	19799	74	230	122	22	97	60	49	13	20	13	40	
50-5A2	50	5	3.175	50.6	47.324	1.5x2	96	1447	5382	70	107	104	16	86	56	40	9	14	8.5	30	
50-5A3				50.6	47.324	1.5x3	143	2051	8072	70	127	104	16	86	56	40	9	14	8.5	30	
50-5B2		6	3.969	50.8	46.744	2.5x2	161	3093	11149	72	134	106	16	88	57	43	9	14	8.5	30	
50-6B2				50.8	46.744	2.5x3	235	4384	16723	72	170	106	16	88	57	43	9	14	8.5	30	
50-8B1		8	4.763	51	46.132	2.5x1	81	2206	6705	75	112	116	18	95	58	45	11	17.5	11	30	
50-8B2				51	46.132	2.5x2	165	4004	13409	75	160	116	18	95	58	45	11	17.5	11	30	
50-8B3		10	6.350	51	46.132	2.5x3	244	5674	20114	75	208	116	18	95	58	45	11	17.5	11	30	
50-10B2				51.4	44.91	2.5x2	173	5923	17670	78	194	119	18	98	62	48	11	17.5	11	30	
50-10B3		12	7.938	51.4	44.91	2.5x3	255	8394	26505	78	254	119	18	98	62	48	11	17.5	11	30	
50-10C1				51.4	44.91	3.5x1	120	4393	12481	78	154	119	18	98	62	48	11	17.5	11	30	
50-12B2		55	10	6.350	51.8	43.688	2.5x2	178	8022	22094	82	232	130	22	105	64	52	13	20	13	40
50-12C1					51.8	43.688	3.5x1	123	5875	15380	82	184	130	22	105	64	52	13	20	13	40
55-10C1	55	12	7.938	56.4	49.91	3.5x1	132	4562	13661	84	154	125	18	103	68	54	11	17.5	11	40	
55-12B2				56.8	48.688	2.5x2	185	8392	24390	88	232	136	22	110	70	56	13	20	13	40	

Remark : Stiffness values listed above are derived from theoretical formula while preload is 10% of dynamic load rating.

**F D V TYPE**

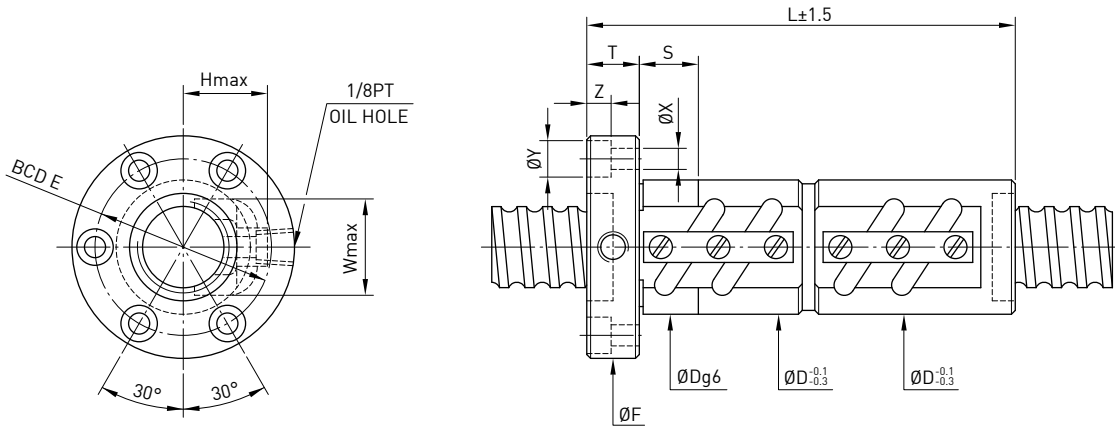

Model	Size		Ball Dia.	PCD	RD	Circuits	Stiffness kgf / $\mu\text{m}$ K	Dynamic Load $1 \times 10^6$ revs C (kgf)	Static Load Co (kgf)	Nut		Flange			Return Tube		Bolt			Fit
	Nominal Dia.	Lead								D	L	F	T	BCD-E	W	H	X	Y	Z	
63-8A2	63	8	4.763	64	59.132	1.5x2	107	2826	10129	87	142	129	18	107	70	50	11	17.5	11	40
63-8A3				64	59.132	1.5x3	154	4004	15193	87	171	129	18	107	70	50	11	17.5	11	40
63-10B2		10	6.350	64.4	57.91	2.5x2	206	6533	22371	90	196	132	20	110	74	56	11	17.5	11	30
63-10B3				64.4	57.91	2.5x3	305	9258	33556	90	256	132	20	110	74	56	11	17.5	11	30
63-12B2		12	7.938	64.8	56.688	2.5x2	214	8943	28062	94	232	142	22	117	76	57	13	20	13	40
63-16B2		16	9.525	65.2	55.466	2.5x2	280	14862	46009	100	296	150	22	123	78	62	13	20	13	40
63-20B2				65.2	55.466	2.5x2	280	14862	46009	100	334	150	22	123	78	62	13	20	13	40
70-10B2	70	10	6.350	71.4	64.91	2.5x2	228	6843	25011	104	196	152	20	128	80	56	13	20	13	40
70-10B3				71.4	64.91	2.5x3	334	9698	37516	104	256	152	20	128	80	56	13	20	13	40
70-12B2		12	7.938	71.8	63.688	2.5x2	236	9382	31275	110	232	159	22	133	82	58	13	20	13	40
70-12B3				71.8	63.688	2.5x3	336	13296	46912	110	302	159	22	133	82	58	13	20	13	40
80-10B2	80	10	6.350	81.4	74.91	2.5x2	251	7202	28538	115	200	163	22	137	90	64	13	20	13	40
80-10B3				81.4	74.91	2.5x3	368	10207	42807	115	260	163	22	137	90	64	13	20	13	40
80-12B2		12	7.938	81.8	73.688	2.5x2	257	9797	35422	120	232	169	22	143	92	67	13	20	13	40
80-12B3				81.8	73.688	2.5x3	380	13884	53132	120	302	169	22	143	92	67	13	20	13	40
80-16B2		16	9.525	82.2	72.466	2.5x2	340	16485	58851	125	302	190	28	154	94	70	18	26	17.5	50
80-16B3				82.2	72.466	2.5x3	498	23363	88276	125	398	190	28	154	94	70	18	26	17.5	50
80-20B2				20	9.525	82.2	72.466	2.5x2	338	16485	58851	125	345	190	28	154	94	70	18	26
80-20B3	82.2	72.466	2.5x3			498	23363	88276	125	470	190	28	154	94	70	18	26	17.5	50	
100-12B2	100	12	7.938	101.8	93.688	2.5x2	301	10761	44596	145	240	209	28	173	112	76	18	26	17.5	50
100-12B3				101.8	93.688	2.5x3	452	15251	66894	145	312	209	28	173	112	76	18	26	17.5	50
100-16B2		16	9.525	102.2	92.466	2.5x2	400	18125	74425	150	308	228	32	185	114	80	22	32	21.5	60
100-16B3				102.2	92.466	2.5x3	595	25684	111637	150	404	228	32	185	114	80	22	32	21.5	60
100-20B2		20	9.525	102.2	92.466	2.5x2	400	18123	74425	150	350	228	32	185	114	80	22	32	21.5	60
100-20B3				102.2	92.466	2.5x3	595	25684	111637	150	475	228	32	185	114	80	22	32	21.5	60

Remark : Stiffness values listed above are derived from theoretical formula while preload is 10% of dynamic load rating.

**F D W TYPE**

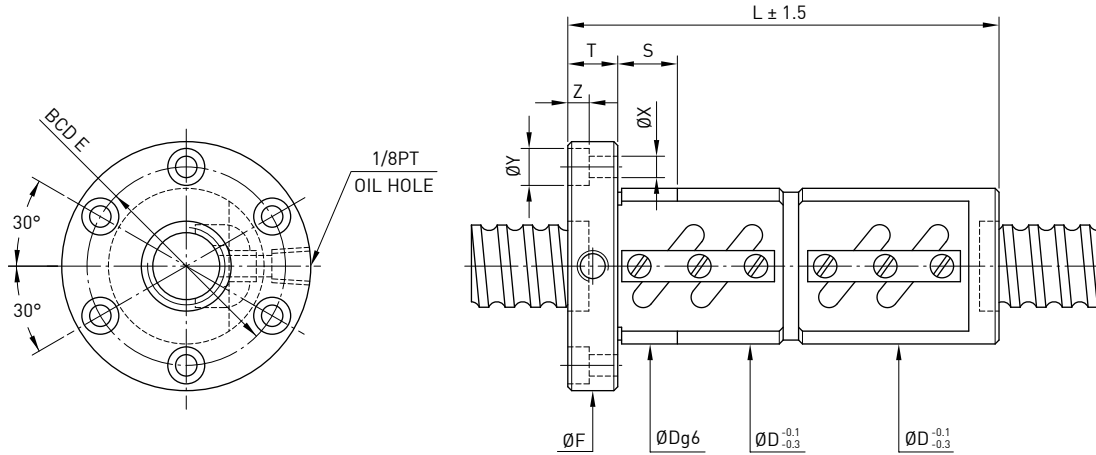

Model	Size		Ball Dia.	PCD	RD	Circuits	Stiffness kgf / $\mu\text{m}$ K	Dynamic Load $1 \times 10^6$ revs C (kgf)	Static Load Co (kgf)	Nut		Flange			Bolt			Fit
	Nominal Dia.	Lead								D	L	F	T	BCD-E	X	Y	Z	
16-5B2	16	5	3.175	16.6	13.324	2.5x2	65	1385	2799	40	110	64	12	51	5.5	9.5	5.5	24
16-5B1				16.6	13.324	2.5x1	32	763	1400	40	80	64	12	51	5.5	9.5	5.5	24
16-5C1				16.6	13.324	3.5x1	46	1013	1946	40	90	64	12	51	5.5	9.5	5.5	24
20-5B1	20	6	3.969	20.6	17.324	2.5x1	38	837	1733	44	80	68	12	55	5.5	9.5	5.5	24
20-5B2				20.6	17.324	2.5x2	76	1519	3465	44	110	68	12	55	5.5	9.5	5.5	24
20-6B1				20.8	16.744	2.5x1	40	1139	2187	48	92	72	12	59	5.5	9.5	5.5	24
20-6C1	20.8	16.744	3.5x1	55	1512	3041	48	104	72	12	59	5.5	9.5	5.5	24			
25-5A2	25	5	3.175	25.6	22.324	1.5x2	54	1092	2622	50	102	73	11	61	5.5	9.5	5.5	24
25-5B1				25.6	22.324	2.5x1	46	939	2209	50	80	74	12	62	5.5	9.5	5.5	24
25-5B2				25.6	22.324	2.5x2	90	1704	4417	50	110	74	12	62	5.5	9.5	5.5	24
25-5C1	25.6	22.324	3.5x1	68	1252	3085	50	90	74	12	62	5.5	9.5	5.5	24			
25-6B2	25	6	3.969	25.8	21.744	2.5x2	94	2304	5524	56	128	82	12	69	6.6	11	6.5	24
25-6C1				25.8	21.744	3.5x1	66	1690	3844	56	104	82	12	69	6.6	11	6.5	24
25-10B1				26	21.132	2.5x1	48	1592	3237	60	122	86	16	73	6.6	11	6.5	24
28-5B1	28	5	3.175	28.6	25.324	2.5x1	51	984	2466	55	80	85	12	69	6.6	11	6.5	24
28-5B2				28.6	25.324	2.5x2	98	1785	4932	55	110	85	12	69	6.6	11	6.5	24
28-6A2				28.6	25.324	1.5x2	59	1150	2960	55	110	85	12	69	6.6	11	6.5	24
28-6B2	28.6	25.324	2.5x2	98	1776	4980	55	123	85	12	69	6.6	11	6.5	24			
32-4B2	32	4	2.381	32.6	29.324	2.5x1	55	1039	2833	58	80	84	12	71	6.6	11	6.5	24
32-5B1				32.6	29.324	2.5x2	109	1886	5666	58	110	84	12	71	6.6	11	6.5	24
32-5B2				32.6	29.324	3.5x1	76	1388	3967	58	90	84	12	71	6.6	11	6.5	24
32-5C1	32.6	29.324	3.5x1	76	1388	3967	58	90	84	12	71	6.6	11	6.5	24			
32-6B1	32	6	3.969	32.8	28.744	2.5x1	57	1409	3510	62	92	88	12	75	6.6	11	6.5	24
32-6B2				32.8	28.744	2.5x2	112	2556	7020	62	128	88	12	75	6.6	11	6.5	24
32-6C1				32.8	28.744	3.5x1	78	1888	4936	62	104	88	12	75	6.6	11	6.5	24
32-8A2	32	8	4.763	33	28.132	1.5x2	70	2082	5151	66	135	100	15	82	9	14	8.5	30
32-8B1				33	28.132	2.5x1	58	1810	4227	66	110	100	16	82	9	14	8.5	30
32-8B2				33	28.132	2.5x2	115	3284	8453	66	158	100	16	82	9	14	8.5	30
32-8B3	33	28.132	2.5x3	168	4653	12678	74	205	108	16	90	9	14	8.5	30			
32-8C1	33	28.132	3.5x1	82	2428	5948	66	126	100	16	82	9	14	8.5	30			
32-10A2	32	10	6.350	33.4	26.91	1.5x2	72	3051	6612	74	167	108	15	90	9	14	8.5	30
32-10B1				33.4	26.91	2.5x1	58	2651	5600	74	122	108	16	90	9	14	8.5	30
32-10B2				33.4	26.91	2.5x2	118	4810	11199	74	182	108	16	90	9	14	8.5	30
32-10C1	33.4	26.91	3.5x1	86	3519	7785	74	142	108	16	90	9	14	8.5	30			
32-12B1	32	12	6.350	33.4	26.91	2.5x1	62	2602	5510	74	153	108	18	90	9	14	8.5	30
32-12B2				33.4	26.91	2.5x2	118	4810	11199	74	232	108	16	90	9	14	8.5	30
32-12C1				33.4	26.91	3.5x1	84	3518	7784	74	166	108	16	90	9	14	8.5	30

Remark : Stiffness values listed above are derived from theoretical formula while preload is 10% of dynamic load rating.

**F D W TYPE**

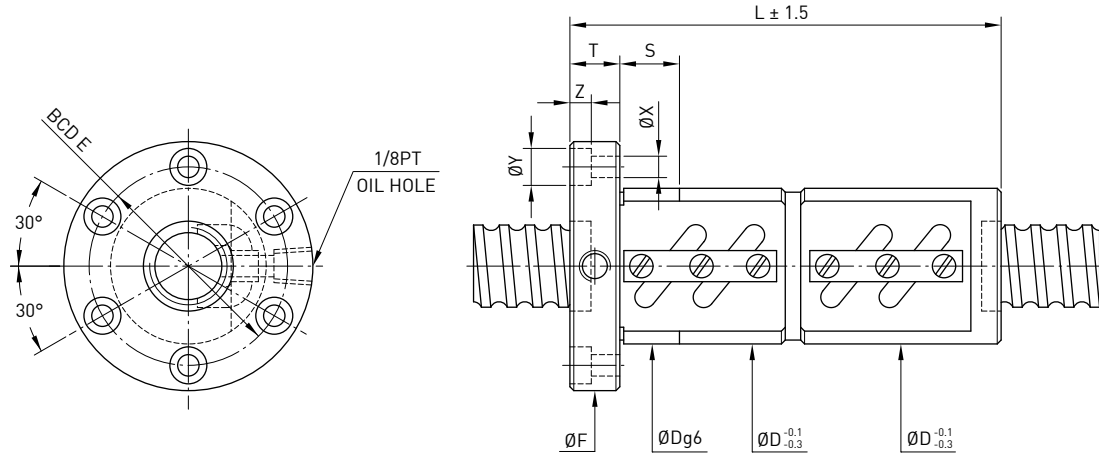

Model	Size		Ball Dia.	PCD	RD	Circuits	Stiffness kgf / $\mu\text{m}$ K	Dynamic Load $1 \times 10^6$ revs C (kgf)	Static Load Co (kgf)	Nut		Flange			Bolt			Fit
	Nominal Dia.	Lead								D	L	F	T	BCD-E	X	Y	Z	
36-6B1	36	6	3.969	36.8	32.744	2.5x1	62	1486	3969	65	92	100	12	82	6.6	11	6.5	24
36-6B2			36.8	32.744	2.5x2	121	2696	7937	65	128	100	12	82	6.6	11	6.5	24	
36-12A2		12	4.763	37	32.132	1.5x2	80	2557	6693	70	155	108	15	90	9	14	8.5	30
36-12B1			37.4	30.91	2.5x1	67	2812	6334	75	126	120	16	98	11	17.5	11	30	
36-10B2		10	6.350	37.4	30.91	2.5x2	132	5105	12669	75	184	120	18	98	11	17.5	11	30
36-12B2				37.4	30.91	2.5x2	130	5105	12668	75	206	120	18	98	11	17.5	11	30
36-8A2		8	4.763	37	32.132	1.5x2	77	2217	5669	70	135	108	15	90	9	14	8.5	30
36-8B2				37	32.132	2.5x2	126	3489	9606	70	158	108	15	90	9	14	8.5	30
40-5B1	40	5	3.175	40.6	37.324	2.5x1	65	1141	3567	68	84	102	16	84	9	14	8.5	30
40-5B2			40.6	37.324	2.5x2	132	2071	7134	68	114	102	16	84	9	14	8.5	30	
40-6B2		6	3.969	40.8	36.744	2.5x2	136	2817	8855	70	132	104	16	86	9	14	8.5	30
40-8B1				41	36.132	2.5x1	69	2003	5302	74	110	108	16	90	9	14	8.5	30
40-8B2		8	4.763	41	36.132	2.5x2	137	3634	10603	74	158	108	16	90	9	14	8.5	30
40-8B3				41	36.132	2.5x3	200	5150	15904	74	210	108	15	90	9	14	8.5	30
40-8C1		8	4.763	41	36.132	3.5x1	96	2679	7438	74	126	108	16	90	9	14	8.5	30
40-10A2				41.4	34.91	1.5x2	87	3418	8398	82	170	124	18	102	11	17.5	11	30
40-10B1	10	6.350	41.4	34.91	2.5x1	72	2959	7069	84	132	125	18	104	11	17.5	11	30	
40-10B2			41.4	34.91	2.5x2	145	5370	14138	84	192	125	18	104	11	17.5	11	30	
40-10C1	10	6.350	41.4	34.91	3.5x1	102	3932	9841	84	152	125	18	104	11	17.5	11	30	
40-12A2			41.6	34.299	1.5x2	88	4006	9404	86	160	128	18	106	11	17.5	11	30	
40-12B1	12	7.144	41.6	34.299	2.5x1	70	3425	7837	86	153	128	18	106	11	17.5	11	40	
40-12B2			41.6	34.299	2.5x2	141	6217	15674	86	225	128	18	106	11	17.5	11	40	
40-12C1	12	7.144	41.6	34.299	3.5x1	103	4637	11146	86	179	128	18	106	11	17.5	11	30	
40-16A2			41.6	34.299	1.5x2	83	4007	9405	86	214	128	18	106	11	17.5	11	40	
40-16B1	16	7.144	41.6	34.299	2.5x1	72	3425	7837	86	182	128	18	106	11	17.5	11	40	
40-16B2			41.6	34.299	2.5x2	143	6216	15674	86	272	128	22	106	11	17.5	11	30	
45-10B1	45	10	6.350	46.4	39.91	2.5x1	76	3111	7953	88	134	132	18	110	11	17.5	11	30
45-10B2				46.4	39.91	2.5x2	156	5655	15905	88	194	132	18	110	11	17.5	11	30
45-12B2				46.8	38.688	2.5x2	162	7627	19799	96	230	142	22	117	13	20	13	40
45-16B2	16	7.144	46.6	39.299	2.5x2	158	6636	17895	90	278	132	18	110	11	17.5	11	30	
50-5A2	50	5	3.175	50.6	47.324	1.5x2	96	1447	5382	80	107	114	16	96	9	14	8.5	30
50-5A3				50.6	47.324	1.5x3	143	2051	8072	80	127	114	16	96	9	14	8.5	30
50-6B2		6	3.969	50.8	46.744	2.5x2	161	3093	11149	84	134	118	16	100	9	14	8.5	30
50-6B3				50.8	46.744	2.5x3	235	4384	16723	84	170	118	16	100	9	14	8.5	30
50-8B1		8	4.763	51	46.132	2.5x1	81	2206	6705	87	112	128	18	107	11	17.5	11	30
50-8B2				51	46.132	2.5x2	165	4004	13409	87	160	128	18	107	11	17.5	11	30
50-8B3		8	4.763	51	46.132	2.5x3	244	5674	20114	87	208	128	18	107	11	17.5	11	30
50-10B1				10	6.350	51.4	44.91	2.5x1	88	3245	8918	93	133	135	18	113	11	17.5

Remark : Stiffness values listed above are derived from theoretical formula while preload is 10% of dynamic load rating.

**F D W TYPE**

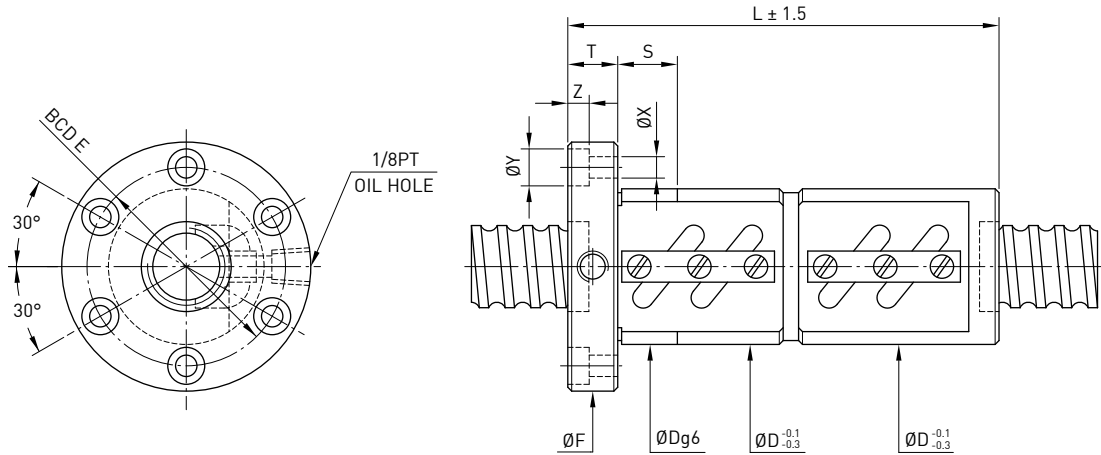

Model	Size		Ball Dia.	PCD	RD	Circuits	Stiffness kgf / $\mu\text{m}$ K	Dynamic Load $1 \times 10^6$ revs C (kgf)	Static Load Co (kgf)	Nut		Flange			Bolt			Fit	
	Nominal Dia.	Lead								D	L	F	T	BCD-E	X	Y	Z		S
50-10B2	50	10	6.350	51.4	44.91	2.5x2	173	5923	17670	94	194	135	18	114	11	17.5	11	30	
50-10B3				51.4	44.91	2.5x3	255	8394	26505	94	254	135	18	114	11	17.5	11	30	
50-10C1		12	7.938	51.4	44.91	3.5x1	120	4393	12481	94	154	135	18	114	11	17.5	11	30	
50-12B1				51.8	43.688	2.5x1	90	4367	10918	100	159	146	22	122	14	20	13	40	
50-12B2		16	16	7.938	51.8	43.688	2.5x2	178	8022	22094	102	232	150	22	125	13	20	13	40
50-12C1					51.8	43.688	3.5x1	123	5875	15380	102	184	150	22	125	13	20	13	40
50-16B2		20	20	9.525	51.8	43.688	2.5x2	174	7918	21837	100	280	146	22	122	14	20	13	40
50-20B1					51.8	43.688	2.5x1	90	4367	10918	100	227	146	28	122	14	20	13	40
55-10C1	55	10	6.350	56.4	49.91	3.5x1	132	4562	13661	100	154	140	18	118	11	17.5	11	40	
55-12B2		12	7.938	56.8	48.688	2.5x2	185	8392	24390	105	232	154	22	127	13	20	13	40	
63-8A2	63	8	4.763	64	59.132	1.5x2	107	2826	10129	104	142	146	18	124	11	17.5	11	40	
63-8A3				64	59.132	1.5x3	154	4004	15193	104	174	146	18	124	11	17.5	11	40	
63-10B2		10	6.350	64.4	57.91	2.5x2	206	6533	22371	110	196	152	20	130	11	17.5	11	30	
63-10B3				64.4	57.91	2.5x3	305	9258	33556	110	256	152	20	130	11	17.5	11	30	
63-12B2		12	7.938	9.525	64.8	56.688	2.5x2	214	8943	28062	118	232	166	22	141	13	20	13	40
63-16B2					65.2	55.466	2.5x2	280	14862	46009	124	296	172	22	147	13	20	13	40
63-20B2		20	20	9.525	65.2	55.466	2.5x2	280	14862	46009	124	334	172	22	147	13	20	13	40
70-10B2					70	10	6.350	71.4	64.91	2.5x2	228	6843	25011	124	196	170	20	145	13
70-10B3	71.4	64.91	2.5x3	334				9698	37516	124	256	170	20	145	13	20	13	40	
70-12B2	12	7.938	9.525	71.8		63.688	2.5x2	236	9382	31275	130	232	178	22	152	13	20	13	40
70-12B3				71.8		63.688	2.5x3	336	13296	46912	130	302	178	22	152	13	20	13	40
70-20B2	20	20	9.525	72.2		62.466	2.5x2	300	15644	51502	130	325	186	28	158	18	26	17.5	60
80-10B2				80		10	6.350	81.4	74.91	2.5x2	251	7202	28538	130	200	178	22	152	13
80-10B3	81.4	74.91	2.5x3					368	10207	42807	130	260	178	22	152	13	20	13	40
80-12B2	12	7.938	9.525			81.8	73.688	2.5x2	257	9797	35422	136	232	185	22	159	13	20	13
80-12B3					81.8	73.688	2.5x3	380	13884	53132	136	302	185	22	159	13	20	13	40
80-16B2	16	16	9.525		82.2	72.466	2.5x2	340	16485	58851	145	302	210	28	174	18	26	17.5	50
80-16B3					82.2	72.466	2.5x3	498	23363	88276	145	398	210	28	174	18	26	17.5	50
80-20B2	20	20	9.525		82.2	72.466	2.5x2	338	16485	58851	145	345	210	28	174	18	26	17.5	50
80-20B3					82.2	72.466	2.5x3	498	23363	88276	145	470	210	28	174	18	26	17.5	50
100-12B2	100	12	7.938	101.8	93.688	2.5x2	301	10761	44596	160	240	224	28	188	18	26	17.5	50	
100-12B3				101.8	93.688	2.5x3	452	15251	66894	160	312	224	28	188	18	26	17.5	50	
100-16B2		16	16	9.525	102.2	92.466	2.5x2	400	18123	74425	170	308	248	32	205	22	32	21.5	60
100-16B3					102.2	92.466	2.5x3	595	25684	111637	170	404	248	32	205	22	32	21.5	60
100-20B2		20	20	9.525	102.2	92.466	2.5x2	400	18123	74425	170	350	248	32	205	22	32	21.5	60
100-20B3					102.2	92.466	2.5x3	595	25684	111637	170	475	248	32	205	22	32	21.5	60

Remark : Stiffness values listed above are derived from theoretical formula while preload is 10% of dynamic load rating.

**F S I TYPE**

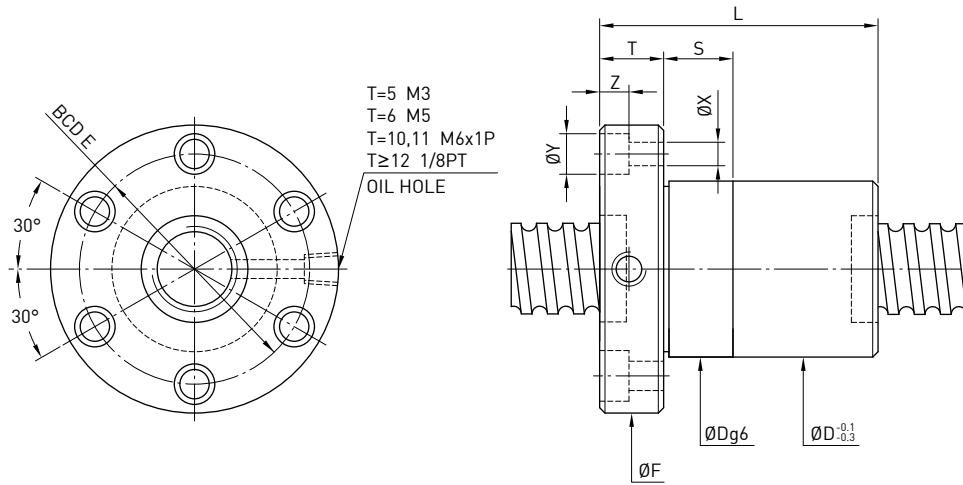

Model	Size		Ball Dia.	PCD	RD	Circuits	Stiffness kgf / $\mu\text{m}$ K	Dynamic Load $1 \times 10^6$ revs C (kgf)	Static Load Co (kgf)	Flange				Bolt			Fit			
	Nominal Dia.	Lead								D	L	F	T	BCD-E	X	Y		Z	S	
8-2.5T3	8	2.5	1.500	8.2	6.652	3	8	170	267	18	28	35	5	27	4.5	0	0	0		
14-2.54T3	14	2.54	2.000	14.2	12.136	3	12	339	655	30	39	50	10.6	40	5	7	5	0		
14-4T3		4		14.2	12.136	3	12	339	655	26	33	48	6	36	5.5	0	0	0		
16-2T3	16	2	1.500	16.2	14.652	3	14	252	593	27	36	44	10	34	4.5	8	4.5	0		
16-2.5T4		2.5		16.2	14.652	4	19	358	862	27	44	44	10	34	4.5	8	4.5	12		
16-5T3		5	3.175	16.6	13.324	3	11	731	1331	30	46	54	12	41	5.5	9.5	5.5	12		
16-5T4				16.6	13.324	4	12	936	1775	30	52	54	12	41	5.5	9.5	5.5	12		
16-6T4				6	16.6	13.324	4	21	936	1775	32	58	54	12	42	5.5	9.5	5.5	12	
20-2T6				20	2	1.500	20.2	18.652	6	32	518	1551	32	52	52	10	40	5.5	9.5	5.5
20-2T4	20.2	18.652	4				36	399	1112	32	40	52	10	40	5.5	9.5	5.5	12		
20-2.5T5	2.5	2.000	20.2		18.136	5	28	637	1635	36	51	59	12	47	5.5	9.5	5.5	12		
20-2.54T6	2.54		20.2		18.136	6	33	745	1962	36	55	59	12	47	5.5	9.5	5.5	12		
20-4T3	4	2.381	20.25		17.792	3	17	509	1134	36	40	59	10	47	5.5	9.5	5.5	12		
20-5T3	5	3.175	20.6		17.324	3	20	852	1767	34	46	57	12	45	5.5	9.5	5.5	12		
20-5T4			20.6		17.324	4	27	1091	2356	34	53	57	12	45	5.5	9.5	5.5	12		
20-6T3			6		3.969	20.8	16.744	3	20	1091	2081	36	51	60	12	48	5.5	9.5	5.5	12
20-6T4						20.8	16.744	4	27	1398	2774	36	61	60	12	48	5.5	9.5	5.5	12
20-10T3	10		20.8		16.744	3	20	1091	2080	35	64	57	12	45	5.5	9.5	5.5	12		
25-2T6	25	2	1.500	25.2	23.652	6	39	560	1960	36	50	58	10	46	5.5	9.5	5.5	12		
25-2T4				25.2	23.652	4	27	395	1307	36	40	58	10	46	5.5	9.5	5.5	12		
25-2T3		2.5	2.000	25.2	23.652	3	20	309	980	36	35	58	10	46	5.5	9.5	5.5	12		
25-2.5T5				25.2	23.136	5	34	716	2117	40	52	64	10	51	6.6	11	6.5	12		
25-4T4				4	2.381	25.25	22.792	4	28	747	1989	40	53	64	12	51	5.5	9.5	5.5	12
25-5T3				5	3.175	25.6	22.324	3	28	977	2314	40	46	64	11	51	5.5	9.5	5.5	10
25-5T4		25.6	22.324			4	37	1252	3085	40	51	64	11	51	5.5	9.5	5.5	10		
25-5T5		25.6	22.324			5	40	1516	3856	40	56	63	11	51	5.5	9.5	5.5	10		
25-5T6		25.6	22.324			6	48	1773	4627	40	65	63	11	51	5.5	9.5	5.5	10		
25-6T3		6	3.969	25.8	21.744	3	28	1272	2762	42	51	65	12	53	5.5	9.5	5.5	12		
25-6T4	25.8			21.744	4	37	1628	3682	42	61	65	12	53	5.5	9.5	5.5	12			
25-10T3	10	4.763	26	21.132	3	25	1591	3236	45	65	69	15	55	6.6	11	6.5	12			
25-10T4			26	21.132	4	33	2038	4315	45	80	69	15	55	6.6	11	6.5	12			

Remark : Stiffness values listed above value are derived from theoretical formula while axial load is 30% of dynamic load rating without preload.

**F S I TYPE**

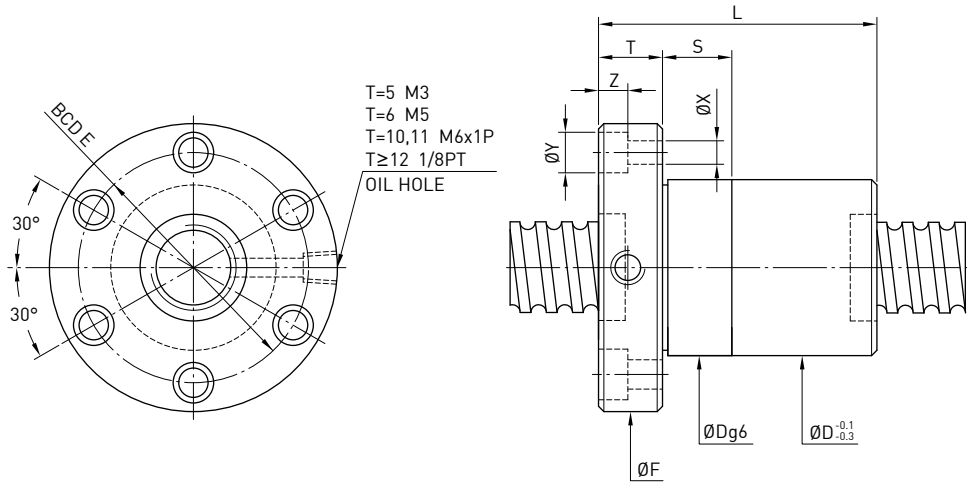

Model	Size		Ball Dia.	PCD	RD	Circuits	Stiffness kgf / $\mu\text{m}$ K	Dynamic Load $1 \times 10^6$ revs C (kgf)	Static Load Co (kgf)	Nut		Flange			Bolt			Fit	
	Nominal Dia.	Lead								D	L	F	T	BCD-E	X	Y	Z		S
32-5T3	32	5	3.175	32.6	29.324	3	33	1117	3081	44	48	46	74	12	60	6.6	11	6.5	12
32-5T4				32.6	29.324	4	42	1431	4108	44	48	53	74	12	60	6.6	11	6.5	12
32-5T6		32.6	29.324	6	63	2027	6162	44	48	66	74	12	60	6.6	11	6.5	12		
32-6T3		6	3.969	32.8	28.744	3	33	1446	3620	45	50	51	76	12	62	6.6	11	6.5	12
32-6T4				32.8	28.744	4	43	1852	4826	45	50	61	76	12	62	6.6	11	6.5	12
32-6T6		32.8	28.744	6	65	2625	7239	45	50	75	76	12	62	6.6	11	6.5	12		
32-8T3		8	4.763	33	28.132	3	35	1810	4227	47	52	63	78	16	64	6.6	11	6.5	12
32-8T4				33	28.132	4	47	2317	5635	47	52	74	78	16	64	6.6	11	6.5	12
32-10T3		10	6.350	33.4	26.91	3	35	2539	5327	51	56	72	82	16	68	6.6	11	6.5	12
32-10T4				33.4	26.91	4	48	3252	7102	51	56	83	82	16	68	6.6	11	6.5	12
40-5T4	40	5	3.175	40.6	37.324	4	50	1599	5280	51	54	53	80	16	66	6.6	11	6.5	12
40-5T6				40.6	37.324	6	74	2265	7919	51	54	66	80	16	66	6.6	11	6.5	12
40-5.08T6		5.08	3.175	40.6	37.324	6	74	2265	7919	53	56	65	90	15	72	9	14	8.5	15
40-6T4		6	3.969	40.8	36.744	4	50	2136	6420	53	56	65	88	16	72	9	14	8.5	15
40-6T6				40.8	36.744	6	74	3028	9630	53	56	79	88	16	72	9	14	8.5	15
40-8T4		8	4.763	41	36.132	4	52	2728	7596	55	60	78	92	16	75	9	14	8.5	15
40-8T6				41	36.132	6	76	3866	11394	55	60	99	92	16	75	9	14	8.5	15
40-10T3		10	6.350	41.4	34.91	3	40	2959	7069	60	65	76	96	16	80	9	14	8.5	15
40-10T4				41.4	34.91	4	51	3789	9426	60	65	87	96	16	80	9	14	8.5	15
50-5T4		50	5	3.175	50.6	47.324	4	62	1757	6745	62	65	57	96	16	80	9	14	8.5
50-5T6	50.6				47.324	6	91	2490	10117	62	65	70	96	16	80	9	14	8.5	15
50-6T4	6		3.969	50.8	46.744	4	62	2388	8250	64	68	65	100	16	84	9	14	8.5	15
50-6T6				50.8	46.744	6	93	3384	12375	64	68	79	100	16	84	9	14	8.5	15
50-8T4	8		4.763	51	46.132	4	62	2998	9578	65	70	78	102	16	85	9	14	8.5	15
50-8T6				51	46.132	6	92	4249	14367	65	70	99	102	16	85	9	14	8.5	15
50-10T3	10		6.350	51.4	44.91	3	50	3397	9256	69	74	78	114	18	92	11	17.5	11	20
50-10T4				51.4	44.91	4	63	4350	12341	69	74	89	114	18	92	11	17.5	11	20
50-10T6	51.4		44.91	6	94	6165	18511	69	74	112	114	18	92	11	17.5	11	20		
50-12T3	12		7.938	51.8	43.688	3	50	4420	11047	73	78	90	118	18	96	11	17.5	11	20
50-12T4		51.8		43.688	4	63	5660	14730	73	78	103	118	18	96	11	17.5	11	20	
50-20T4	20	9.525	52.2	42.466	4	80	9327	23955	75	78	186	129	28	105	14	20	13	30	

Remark : Stiffness values listed above value are derived from theoretical formula while axial load is 30% of dynamic load rating without preload.



**F S I TYPE**

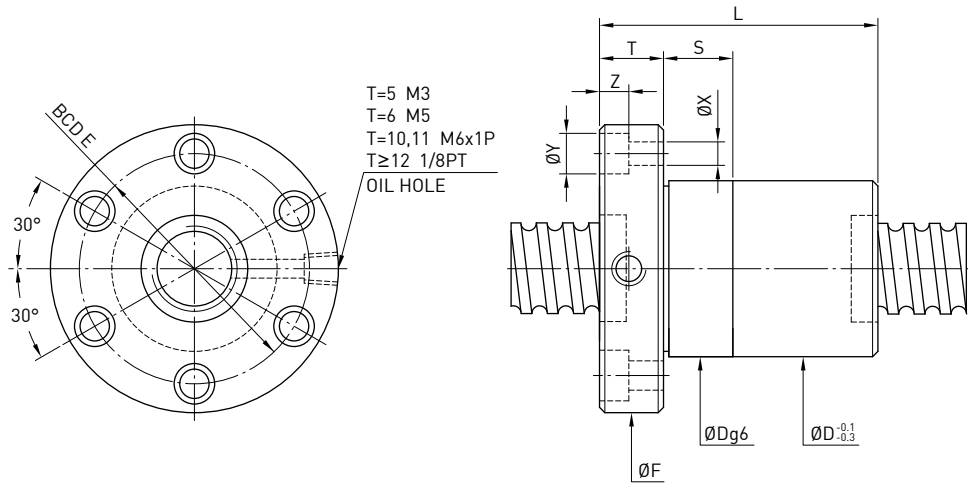

Model	Size		Ball Dia.	PCD	RD	Circuits	Stiffness kgf / $\mu\text{m}$ K	Dynamic Load $1 \times 10^6$ revs C (kgf)	Static Load Co (kgf)	Nut		Flange			Bolt			Fit	
	Nominal Dia.	Lead								D	L	F	T	BCD-E	X	Y	Z		S
63-6T4	63	6	3.969	63.8	59.744	4	75	2614	10542	78	80	66	119	18	98	11	17.5	11	20
63-6T6				63.8	59.744	6	113	3704	15813	78	80	81	119	18	98	11	17.5	11	20
63-8T4		8	4.763	64	59.132	4	77	3395	12541	79	82	80	122	18	100	11	17.5	11	20
63-8T6				64	59.132	6	114	4812	18811	79	82	101	122	18	100	11	17.5	11	20
63-10T4		10	6.350	64.4	57.91	4	79	4860	15858	82	88	91	134	20	110	14	20	13	20
63-10T6				64.4	57.91	6	115	6887	23786	82	88	114	134	20	110	14	20	13	20
63-12T4	12	7.938	64.8	56.688	4	78	6479	19293	86	92	105	138	20	114	14	20	13	20	
63-12T6			64.8	56.688	6	113	9182	28939	86	92	133	138	20	114	14	20	13	20	
80-10T4	80	10	6.350	81.4	74.91	4	96	5559	21118	99	105	91	152	20	127	14	20	13	20
80-10T6				81.4	74.91	6	140	7879	31677	99	105	114	152	20	127	14	20	13	20
80-12T4		12	7.938	81.8	73.688	4	97	7430	25681	103	110	109	170	24	138	18	26	17.5	25
80-12T6				81.8	73.688	6	141	10530	38521	103	110	137	170	24	138	18	26	17.5	25
80-16T3		16	9.525	82.2	72.466	3	95	9663	31622	108	115	118	174	24	143	18	26	17.5	25
80-16T4				82.2	72.466	4	130	12375	42162	108	115	136	174	24	143	18	26	17.5	25
80-20T3	20		9.525	82.2	72.466	3	95	9663	31622	108	115	138	174	24	143	18	26	17.5	25
80-20T4				82.2	72.466	4	125	12375	42162	108	115	161	174	24	143	18	26	17.5	25
100-12T4	100	12	7.938	101.8	93.688	4	105	8306	33001	123	130	109	190	24	158	18	26	17.5	25
100-12T6				101.8	93.688	6	175	11772	49502	123	130	137	190	24	158	18	26	17.5	25
100-16T4		16	9.525	102.2	92.466	4	107	13569	53161	125	135	136	194	24	163	18	26	17.5	30
100-16T6				102.2	92.466	6	140	19230	79741	125	135	173	194	24	163	18	26	17.5	30
100-20T4		20	102.2	92.466	4	155	13569	53161	125	135	161	194	24	163	18	26	17.5	30	

Remark : Stiffness values listed above value are derived from theoretical formula while axial load is 30% of dynamic load rating without preload.

**R S I TYPE**

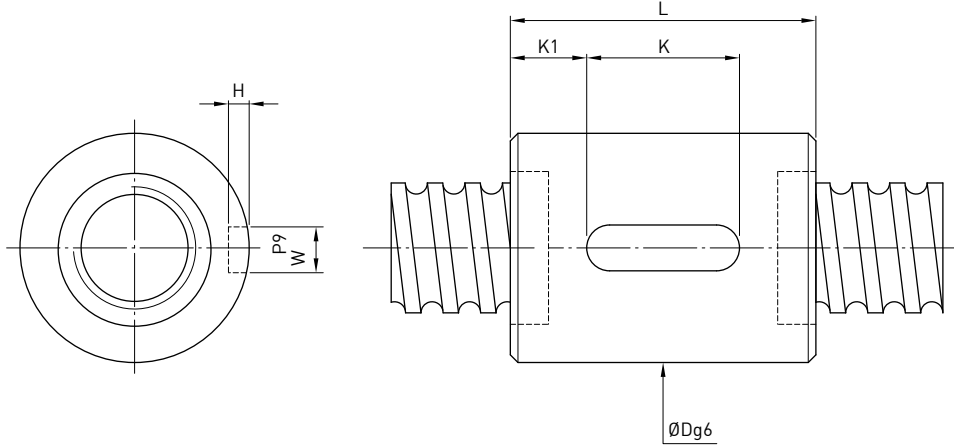

Model	Size		Ball Dia.	PCD	RD	Circuits	Stiffness kgf / μm K	Dynamic Load 1x10 <sup>6</sup> revs C (kgf)	Static Load Co (kgf)	Nut		Keyway				
	Nominal Dia.	Lead								D	L	K	W	H	K1	
16-2T4	16	2	1.500	16.2	14.652	4	15	178	395	25	25	25	20	3	1.8	2.5
16-5T3		5	3.175	16.6	13.324	3	11	731	1331	28	30	40	20	3	1.8	10
16-5T4				16.6	13.324	4	12	936	1775	28	30	46	20	3	1.8	13
20-5T3	20	5	3.175	20.6	17.324	3	20	852	1767	32	34	41	20	3	1.8	10.5
20-5T4				20.6	17.324	4	27	1091	2356	32	34	48	20	3	1.8	14
20-6T3		6	3.969	20.8	16.744	3	20	1091	2081	34	36	46	20	4	2.5	13
20-6T4	20.8			16.744	4	27	1398	2774	34	36	56	25	4	2.5	15.5	
25-5T3	25	5	3.175	25.6	22.324	3	28	977	2314	37	40	41	20	4	2.5	10.5
25-5T4				25.6	22.324	4	37	1252	3085	37	40	48	20	4	2.5	14
25-6T3		6	3.969	25.8	21.744	3	28	1272	2762	38	42	46	20	4	2.5	13
25-6T4	25.8			21.744	4	37	1628	3682	38	42	56	25	4	2.5	15.5	
32-5T3	32	5	3.175	32.6	29.324	3	33	1117	3081	44	48	41	20	4	2.5	10.5
32-5T4				32.6	29.324	4	42	1431	4108	44	48	48	20	4	2.5	14
32-5T6		6	3.969	32.6	29.324	6	63	2027	6162	44	48	61	25	4	2.5	18
32-6T3				32.8	28.744	3	33	1446	3620	45	50	46	20	5	3	13
32-6T4				32.8	28.744	4	43	1852	4826	45	50	56	25	5	3	15.5
32-6T6				32.8	28.744	6	65	2625	7239	45	50	70	32	5	3	19
32-8T3	8	4.763	33	28.132	3	35	1810	4227	47	52	59	25	5	3	17	
32-8T4			33	28.132	4	47	2317	5635	47	52	70	25	5	3	22.5	
32-10T3	40	10	6.350	33.4	26.91	3	35	2539	5327	51	56	68	25	6	3.5	21.5
32-10T4				33.4	26.91	4	48	3252	7102	51	56	79	32	6	3.5	23.5
40-5T4		5	3.175	40.6	37.324	4	50	1599	5280	51	54	48	20	4	2.5	14
40-5T6				40.6	37.324	6	74	2265	7919	51	54	61	25	4	2.5	18
40-6T4	6	3.969	40.8	36.744	4	50	2136	6420	53	56	56	25	5	3	15.5	
40-6T6			40.8	36.744	6	74	3028	9630	53	56	70	32	5	3	19	
40-8T4	8	4.763	41	36.132	4	52	2728	7596	55	60	70	25	5	3	22.5	
40-8T6			41	36.132	6	76	3866	11394	55	60	91	40	5	3	25.5	
40-10T3	10	6.350	41.4	34.91	3	40	2959	7069	60	65	68	25	6	3.5	21.5	
40-10T4			41.4	34.91	4	51	3789	9426	60	65	79	32	6	3.5	23.5	
50-5T4	50	5	3.175	50.6	47.324	4	62	1757	6745	62	65	48	20	4	2.5	14
50-5T6				50.6	47.324	6	91	2490	10117	62	65	61	25	4	2.5	18
50-6T4		6	3.969	50.8	46.744	4	62	2388	8250	64	68	56	25	5	3	15.5
50-6T6				50.8	46.744	6	93	3384	12375	64	68	70	32	5	3	19
50-8T4		8	4.763	51	46.132	4	62	2998	9578	65	70	70	32	5	3	19
50-8T6				51	46.132	6	92	4249	14367	65	70	91	40	5	3	25.5
50-10T3	10	6.350	51.4	44.91	3	50	3397	9256	69	74	68	32	6	3.5	18	
50-10T4			51.4	44.91	4	63	4350	12341	69	74	79	32	6	3.5	23.5	

Remark : Stiffness values listed above value are derived from theoretical formula while axial load is 30% of dynamic load rating without preload.

**R S I TYPE**

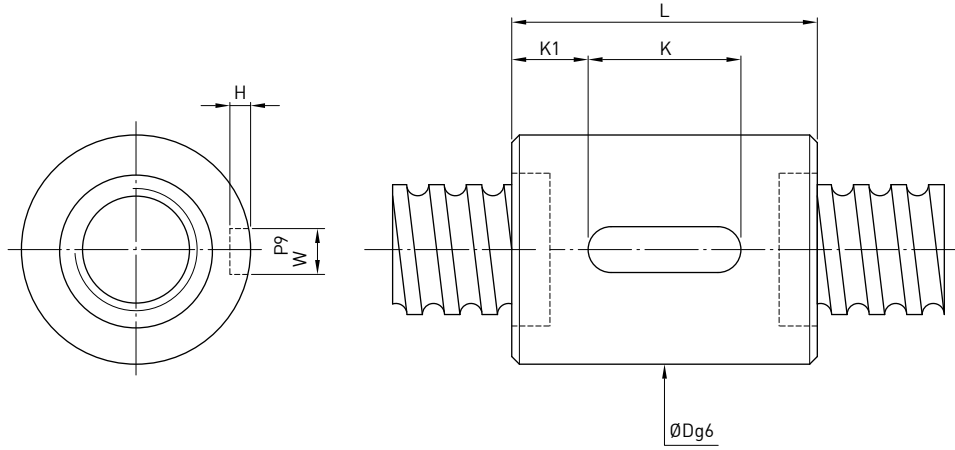

Model	Size		Ball Dia.	PCD	RD	Circuits	Stiffness kgf / $\mu\text{m}$ K	Dynamic Load $1 \times 10^6$ revs C (kgf)	Static Load Co (kgf)	Nut		Keyway				
	Nominal Dia.	Lead								D	L	K	W	H	K1	
50-10T6	50	12	6.350	51.4	44.91	6	94	6165	18511	69	74	102	40	6	3.5	31
50-12T3			7.938	51.8	43.688	3	50	4420	11047	73	78	82	40	6	3.5	21
50-12T4			51.8	43.688	4	63	5660	14730	73	78	95	40	6	3.5	27.5	
63-6T4	63	6	63.8	59.744	4	75	2674	10542	78	80	56	25	6	3.5	15.5	
63-6T6			63.8	59.744	6	113	3704	15813	78	80	70	32	6	3.5	19	
63-8T4		8	64	59.132	4	77	3395	12541	79	82	70	32	6	3.5	19	
63-8T6			64	59.132	6	114	4812	18811	79	82	91	40	6	3.5	25.5	
63-10T4		10	64.4	57.91	4	79	4860	15858	82	88	79	32	8	4	23.5	
63-10T6			64.4	57.91	6	115	6887	23786	82	88	102	40	8	4	31	
63-12T4	12	64.8	56.688	4	78	6479	19293	86	92	95	40	8	4	27.5		
63-12T6		64.8	56.688	6	113	9182	28939	86	92	123	50	8	4	36.5		
80-10T4	80	10	81.4	74.91	4	96	5559	21118	99	105	79	32	8	4	23.5	
80-10T6			81.4	74.91	6	140	7879	31677	99	105	102	40	8	4	31	
80-12T4		12	81.8	73.688	4	97	7430	25681	103	110	95	40	8	4	27.5	
80-12T6			81.8	73.688	6	141	10530	38521	103	110	123	50	8	4	36.5	
80-16T3		16	82.2	72.466	3	95	9663	31622	108	115	106	40	10	5	33	
80-16T4			82.2	72.466	4	130	12375	42162	108	115	124	50	10	5	37	
80-20T3	20	82.2	72.466	3	95	9663	31622	108	115	126	50	10	5	38		
80-20T4		82.2	72.466	4	125	12375	42162	108	115	149	63	10	5	43		
100-12T4	100	12	101.8	93.688	4	105	8306	33001	123	130	95	40	8	4	27.5	
100-12T6			101.8	93.688	6	175	11772	49502	123	130	123	50	8	4	36.5	
100-16T4		16	102.2	92.466	4	107	13569	53161	125	135	124	50	10	5	37	
100-16T6			102.2	92.466	6	140	19230	79741	125	135	161	63	10	5	49	
100-20T4	20	102.2	92.466	4	155	13569	53161	125	135	149	63	10	5	43		

Remark : Stiffness values listed above value are derived from theoretical formula while axial load is 30% of dynamic load rating without preload.

**F D I TYPE**

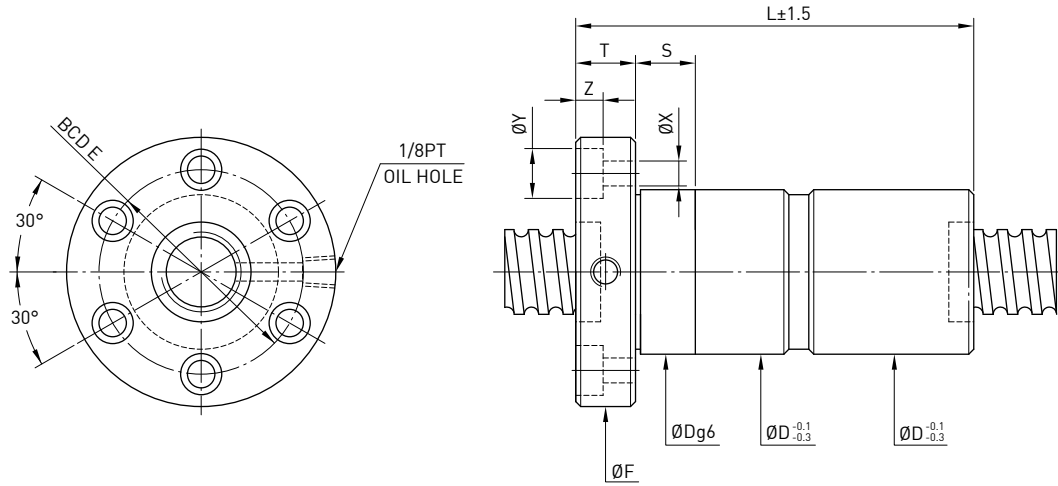

Model	Size		Ball Dia.	PCD	RD	Circuits	Stiffness kgf / $\mu\text{m}$ K	Dynamic Load $1 \times 10^6$ revs C (kgf)	Static Load Co (kgf)	Nut		Flange			Bolt			Fit	
	Nominal Dia.	Lead								D	L	F	T	BCD-E	X	Y	Z		S
16-5T3	16	5	3.175	16.6	13.324	3	20	731	1331	28	30	78	54	12	41	5.5	9.5	5.5	24
16-5T4				16.6	13.324	4	23	936	1775	28	30	90	54	12	41	5.5	9.5	5.5	24
20-5T3	20	6	3.969	20.6	17.324	3	39	852	1767	32	34	78	57	12	45	5.5	9.5	5.5	24
20-5T4				20.6	17.324	4	54	1091	2356	32	34	92	57	12	45	5.5	9.5	5.5	24
20-6T3				20.8	16.744	3	39	1091	2081	34	36	89	60	12	48	5.5	9.5	5.5	24
20-6T4				20.8	16.744	4	54	1398	2774	34	36	109	60	12	48	5.5	9.5	5.5	24
25-2.5T5	25	2.5	2.000	25.2	23.136	5	66	716	2117	35	40	87	65	10	51	6.6	11	6.5	24
25-5T3		5	3.175	25.6	22.324	3	55	977	2314	37	40	78	64	12	52	5.5	9.5	5.5	24
25-5T4				20.6	22.324	4	73	1252	3085	37	40	96	64	12	52	5.5	9.5	5.5	24
25-6T3		6	3.969	25.8	21.744	3	56	1272	2762	38	42	89	65	12	53	5.5	9.5	5.5	24
25-6T4				25.8	21.744	4	75	1628	3682	38	42	109	65	12	53	5.5	9.5	5.5	24
25-10T3		10	4.763	26	21.132	3	49	1643	3265	47	51	140	74	15	60	6.6	11	6.5	24
28-5T5	28	5	3.175	28.6	25.324	5	86	1619	4404	45	50	110	74	12	62	5.5	9.5	5.5	24
28-10T4		10	4.763	29	24.132	4	70	2199	4969	45	50	150	74	12	61	6.6	11	6.5	24
32-2.5T6	32	2.5	2.000	32.2	30.136	6	97	928	3339	45	51	106	74	12	62	5.5	9.5	5.5	24
32-5T3		5	3.175	32.6	29.324	3	64	1117	3081	44	48	78	74	12	60	6.6	11	6.5	24
32-5T4				32.6	29.324	4	82	1431	4108	44	48	96	74	12	60	6.6	11	6.5	24
32-5T6		32.6	29.324	6	121	2027	6162	44	48	118	74	12	60	6.6	11	6.5	24		
32-5.08T4		5.08	32.6	29.324	4	82	1430	4108	44	48	96	74	12	60	6.6	11	6.5	24	
32-6T3		6	3.969	32.8	36.856	3	65	1446	3620	45	50	89	76	12	62	6.6	11	6.5	24
32-6T4				32.8	36.856	4	84	1852	4826	45	50	109	76	12	62	6.6	11	6.5	24
32-6T6		32.8	36.856	6	125	2625	7239	45	50	137	76	12	62	6.6	11	6.5	24		
32-8T3		8	4.763	33	37.868	3	68	1810	4227	47	52	110	78	16	64	6.6	11	6.5	24
32-8T4				33	37.868	4	82	2317	5635	47	52	136	78	16	64	6.6	11	6.5	24
32-10T3	10	6.350	33.4	39.89	3	68	2539	5327	51	56	129	82	16	68	6.6	11	6.5	24	
32-10T4			33.4	39.89	4	82	3252	7102	51	56	155	82	16	68	6.6	11	6.5	24	
40-5T4	40	5	3.175	40.6	37.324	4	99	1599	5280	51	54	96	80	16	66	6.6	11	6.5	24
40-5T6				40.6	37.324	6	146	2265	7919	51	54	122	80	16	66	6.6	11	6.5	24
40-6T4		6	3.969	40.8	36.744	4	100	2136	6420	53	56	113	88	16	72	9	14	8.5	30
40-6T6				40.8	36.744	6	148	3028	9630	53	56	141	88	16	72	9	14	8.5	30
40-8T4		8	4.763	41	36.132	4	102	2728	7596	55	60	136	92	16	75	9	14	8.5	30
40-8T6				41	36.132	6	150	3866	11394	55	60	178	92	16	75	9	14	8.5	30
40-10T3		10	6.350	41.4	34.91	3	76	2959	7069	60	65	133	96	16	80	9	14	8.5	30
40-10T4				41.4	34.91	4	101	3789	9426	60	65	155	96	16	80	9	14	8.5	30
40-10T5				41.4	34.91	5	119	4590	1178	60	65	192	96	16	80	9	14	8.5	30
40-12T3				12	6.350	41.4	34.91	3	73	2958	7069	58	60	160	96	18	80	9	14
40-12T4	41.4	34.91	4			101	3789	9425	58	60	186	96	18	80	9	14	8.5	30	

Remark : Stiffness values listed above are derived from theoretical formula while preload is 10% of dynamic load rating.

**F D I TYPE**

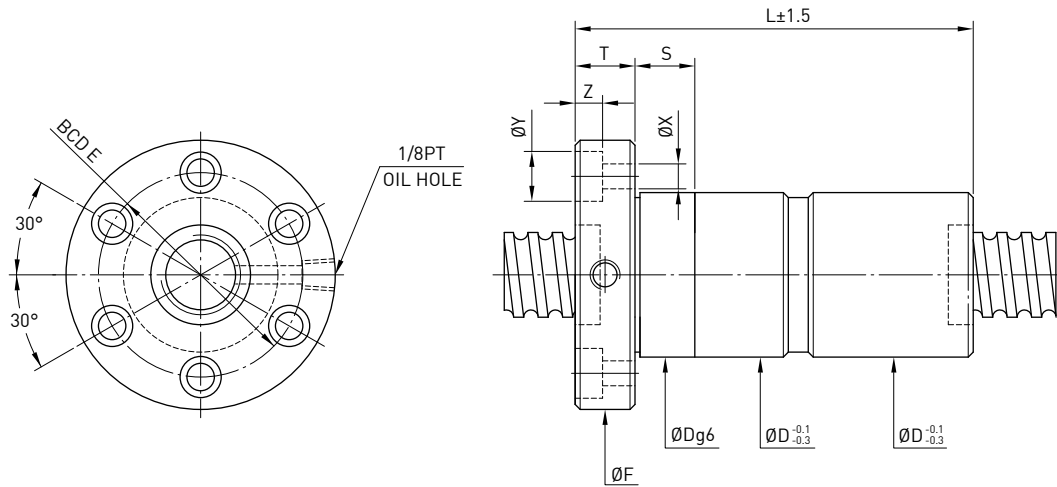

Model	Size		Ball Dia.	PCD	RD	Circuits	Stiffness kgf / $\mu\text{m}$ K	Dynamic Load $1 \times 10^6$ revs C (kgf)	Static Load Co (kgf)	Nut		Flange			Bolt			Fit	
	Nominal Dia.	Lead								D	L	F	T	BCD-E	X	Y	Z		S
45-10T4	45	10	7.144	46.6	39.299	4	108	4683	11930	68	70	160	110	18	90	11	17.5	11	30
45-12T3		12	6.350	46.4	39.91	3	80	3115	7952	68	70	183	110	16	90	11	17.5	11	30
45-16T3		16	7.144	46.6	39.299	3	82	3656	8947	68	70	183	110	16	90	11	17.5	11	30
50-5T4	50	5	3.175	50.6	47.324	4	121	1757	6745	62	65	96	96	16	80	9	14	8.5	30
50-5T6				6	177	2490	10117	62	65	122	96	16	80	9	14	8.5	30		
50-6T4		6	3.969	50.8	46.744	4	123	2388	8250	64	68	113	100	16	84	9	14	8.5	30
50-6T6	6			179	3384	12375	64	68	147	100	16	84	9	14	8.5	30			
50-8T4	50	8	4.763	51	46.132	4	122	2998	9578	65	70	136	102	16	85	9	14	8.5	30
50-8T6				6	178	4249	14367	65	70	178	102	16	85	9	14	8.5	30		
50-10T3		10	6.350	51.4	44.91	3	95	3397	9256	69	74	135	114	18	92	11	17.5	11	40
50-10T4	4			124	4350	12341	69	74	157	114	18	92	11	17.5	11	40			
50-10T6	6			184	6165	18511	69	74	203	114	18	92	11	17.5	11	40			
50-12T3	12	7.938	51.8	43.688	3	94	4420	11047	73	78	158	118	18	96	11	17.5	11	40	
50-12T4			4	124	5660	14730	73	78	184	118	18	96	11	17.5	11	40			
63-6T4			63	6	3.969	63.8	59.744	4	148	2674	10542	78	80	115	119	18	98	11	17.5
63-6T6	6	220				3704	15813	78	80	143	119	18	98	11	17.5	11	40		
63-8T4	8	4.763		64	59.132	4	152	3395	12541	79	82	138	122	18	100	11	17.5	11	40
63-8T6			6	222	4812	18811	79	82	180	122	18	100	11	17.5	11	40			
63-10T4			10	6.350	64.4	57.91	4	158	4860	15858	82	88	159	134	20	110	14	20	13
63-10T6	6	228			6887	23786	82	88	205	134	20	110	14	20	13	40			
63-12T4	12	7.938			64.8	56.688	4	152	6479	19293	86	92	186	138	20	114	14	20	13
63-12T6			6	224	9182	28939	86	92	242	138	20	114	14	20	13	40			
80-10T4			80	10	6.350	81.4	74.91	4	190	5559	21118	99	105	172	152	20	127	14	20
80-10T6	6	277				7879	31677	99	105	214	152	20	127	14	20	13	40		
80-12T4	12	7.938		81.8	73.688	4	192	7430	25681	103	110	190	170	24	138	18	26	17.5	50
80-12T6			6	280	10530	38521	103	110	246	170	24	138	18	26	17.5	50			
80-16T3			16	9.525	82.2	72.466	3	188	9663	31622	108	115	208	174	24	143	18	26	17.5
80-16T4	4	254			12375	42162	108	115	244	174	24	143	18	26	17.5	50			
80-20T3	20	9.525			82.2	72.466	3	189	9663	31622	108	115	250	174	24	143	18	26	17.5
80-20T4			4	248	12375	42162	108	115	296	174	24	143	18	26	17.5	50			
100-12T4	100	12	7.938	101.8	93.688	4	206	8306	33001	123	130	190	190	24	158	18	26	17.5	50
100-12T6				6	343	11772	49502	123	130	246	190	24	158	18	26	17.5	50		
100-16T4		16	9.525	102.2	92.466	4	212	13569	53161	135	135	244	194	24	163	18	26	17.5	60
100-16T6	6			276	19230	79741	135	135	318	194	24	163	18	26	17.5	60			
100-20T4	20	102.2	92.466	4	300	13569	53161	135	135	296	194	24	163	18	26	17.5	60		

Remark : Stiffness values listed above are derived from theoretical formula while preload is 10% of dynamic load rating.

**R D I TYPE**

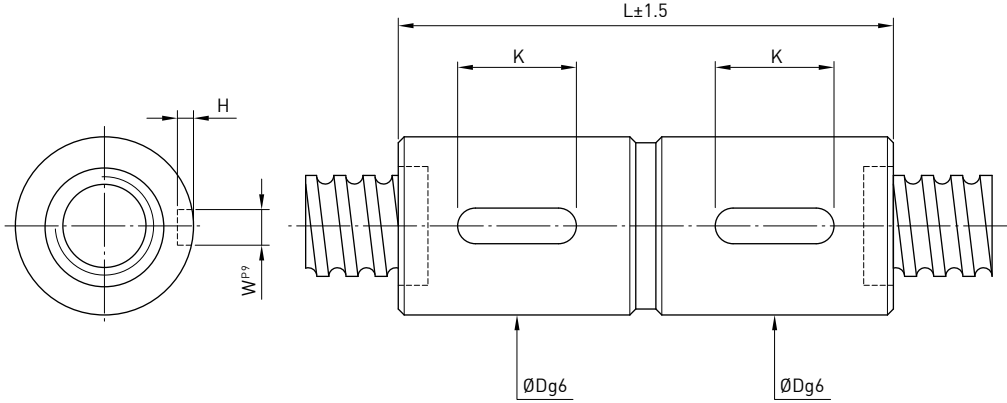

Model	Size		Ball Dia.	PCD	RD	Circuits	Stiffness kgf / $\mu\text{m}$ K	Dynamic Load $1 \times 10^6$ revs C (kgf)	Static Load Co (kgf)	Nut		Keyway				
	Nominal Dia.	Lead								D	L	K	W	H		
16-5T3	16	5	3.175	16.6	13.324	3	20	731	1331	28	30	72	20	3	1.8	
16-5T4				16.6	13.324	4	23	936	1775	28	30	85	20	3	1.8	
20-5T3	20	5		20.6	17.324	3	39	852	1767	32	34	75	20	3	1.8	
20-5T4				20.6	17.324	4	54	1091	2356	32	34	85	20	3	1.8	
20-6T3	20	6	3.969	20.8	16.744	3	39	1091	2081	34	36	87	20	4	2.5	
20-6T4				20.8	16.744	4	54	1398	2774	34	36	103	25	4	2.5	
25-5T3	25	5		25.6	22.324	3	55	977	2314	37	40	75	20	4	2.5	
25-5T4				25.6	22.324	4	73	1252	3085	37	40	85	20	4	2.5	
25-6T3	25	6	3.969	25.8	21.744	3	56	1272	2762	38	42	87	20	4	2.5	
25-6T4				25.8	21.744	4	75	1628	3682	38	42	103	25	4	2.5	
32-5T3	32	5		3.175	32.6	29.324	3	64	1117	3081	44	48	75	20	4	2.5
32-5T4					32.6	29.324	4	82	1431	4108	44	48	85	20	4	2.5
32-5T6		6	3.969	32.6	29.324	6	121	2027	6162	44	48	105	25	4	2.5	
32-6T3				32.8	28.744	3	65	1446	3620	45	50	87	20	5	3	
32-6T4	8	4.763		32.8	28.744	4	84	1852	4826	45	50	103	25	5	3	
32-6T6				32.8	28.744	6	125	2625	7239	45	50	127	32	5	3	
32-8T3	32	8	4.763	33	28.132	3	68	1810	4227	47	52	109	25	5	3	
32-8T4				33	28.132	4	82	2317	5635	47	52	127	25	5	3	
32-10T3	10	6.350		33.4	26.91	3	68	2539	5327	51	56	135	25	6	3.5	
32-10T4				33.4	26.91	4	82	3252	7102	51	56	155	32	6	3.5	
40-5T4	40	5	3.175	40.6	37.324	4	99	1599	5280	51	54	85	20	4	2.5	
40-5T6				40.6	37.324	6	146	2265	7919	51	54	105	25	4	2.5	
40-6T4		6	3.969	40.8	36.744	4	100	2136	6420	53	56	103	25	5	3	
40-6T6				40.8	36.744	6	148	3028	9630	53	56	127	32	5	3	
40-8T4	40	8	4.763	41	36.132	4	102	2728	7596	55	60	127	25	5	3	
40-8T6				41	36.132	6	150	3866	11394	55	60	161	40	5	3	
40-10T3	40	10	6.350	41.4	34.91	3	76	2959	7069	60	65	135	25	6	3.5	
40-10T4				41.4	34.91	4	101	3789	9426	60	65	155	32	6	3.5	

Remark : Stiffness values listed above are derived from theoretical formula while preload is 10% of dynamic load rating.

**R D I TYPE**

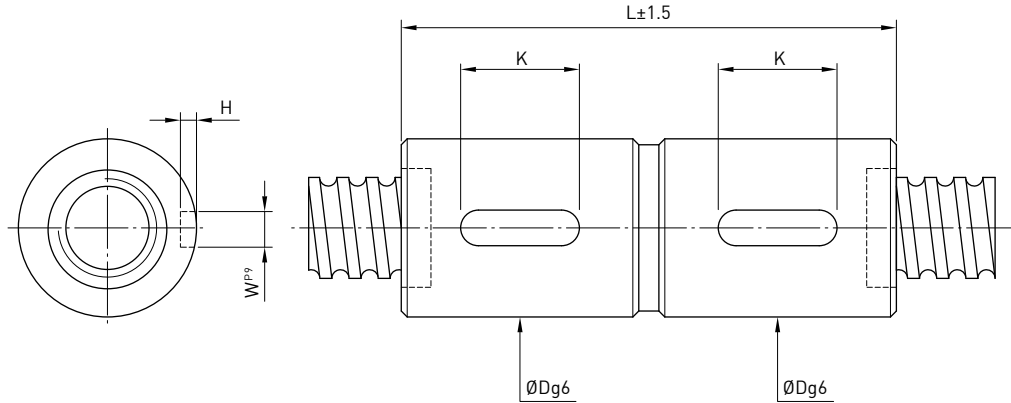

Model	Size		Ball Dia.	PCD	RD	Circuits	Stiffness kgf / $\mu\text{m}$ K	Dynamic Load $1 \times 10^6$ revs C (kgf)	Static Load Co (kgf)	Nut		Keyway				
	Nominal Dia.	Lead								D	L	K	W	H		
50-5T4	50	5	3.175	50.6	47.324	4	121	1757	6745	62	65	85	20	4	2.5	
50-5T6				50.6	47.324	6	177	2490	10117	62	65	105	25	4	2.5	
50-6T4		6	3.969	50.8	46.744	4	123	2388	8250	64	68	103	25	5	3	
50-6T6				50.8	46.744	6	179	3384	12375	64	68	127	32	5	3	
50-8T4		8	4.763	51	46.132	4	122	2998	9578	65	70	127	32	5	3	
50-8T6				51	46.132	6	178	4249	14367	65	70	161	40	5	3	
50-10T3		10	6.350	51.4	44.91	3	95	3397	9256	69	74	135	32	6	3.5	
50-10T4				51.4	44.91	4	124	4350	12341	69	74	155	32	6	3.5	
50-10T6		51.4	44.91	6	184	6165	18511	69	74	197	40	6	3.5			
50-12T3		12	7.938	51.8	43.688	3	94	4420	11047	73	78	161	40	6	3.5	
50-12T4				51.8	43.688	4	124	5660	14730	73	78	185	40	6	3.5	
63-6T4		63	6	3.969	63.8	59.744	4	148	2614	10542	78	80	106	25	6	3.5
63-6T6	63.8				59.744	6	220	3704	15813	78	80	130	32	6	3.5	
63-8T4	8		4.763	64	59.132	4	152	3395	12541	79	82	131	32	6	3.5	
63-8T6				64	59.132	6	222	4812	18811	79	82	165	40	6	3.5	
63-10T4	10		6.350	64.4	57.91	4	158	4860	15858	82	88	160	32	8	4	
63-10T6				64.4	57.91	6	228	6887	23786	82	88	202	40	8	4	
63-12T4	12		7.938	64.8	56.688	4	152	6479	19293	86	92	185	40	8	4	
63-12T6				64.8	56.688	6	224	9182	28939	86	92	238	50	8	4	
63-20T4	20		9.525	65.2	55.466	4	189	10657	31251	90	95	260	50	8	4	
80-10T4	80		10	6.350	81.4	74.91	4	190	5559	21118	99	105	160	32	8	4
80-10T6					81.4	74.91	6	277	7879	31677	99	105	202	40	8	4
80-12T4			12	7.938	81.8	73.688	4	192	7430	25681	103	110	185	40	8	4
80-12T6		81.8			73.688	6	280	10530	38521	103	110	238	50	8	4	
80-16T3		16	9.525	82.2	72.466	3	188	9663	31622	108	115	200	40	10	5	
80-16T4				82.2	72.466	4	254	12375	42162	108	115	236	50	10	5	
80-20T3		20	9.525	82.2	72.466	3	189	9663	31622	108	115	245	50	10	5	
80-20T4				82.2	72.466	4	248	12375	42162	108	115	289	63	10	5	
100-12T4		100	12	7.938	101.8	93.688	4	206	8306	33001	123	130	185	40	8	4
100-12T6					101.8	93.688	6	343	11772	49502	123	130	238	50	8	4
100-16T4			16	9.525	102.2	92.466	4	212	13569	53161	125	135	236	50	10	5
100-16T6					102.2	92.466	6	276	19230	79741	125	135	310	63	10	5
100-20T4	20		9.525	102.2	92.466	4	300	13569	53161	125	135	289	63	10	5	

Remark : Stiffness values listed above are derived from theoretical formula while preload is 10% of dynamic load rating.

**P F D W TYPE 1**

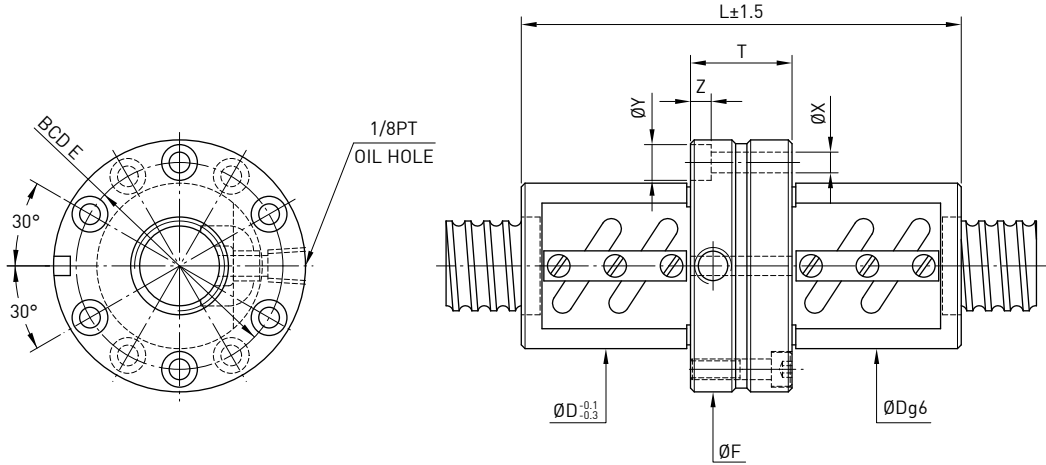

Model	Size		Ball Dia.	PCD	RD	Circuits	Stiffness kgf / $\mu\text{m}$ K	Dynamic Load $1 \times 10^4$ revs C (kgf)	Static Load Co (kgf)	Nut			Flange			Bolt			
	Nominal Dia.	Lead								D	L	T	F	BCD-E	X	Y	Z		
20-5B1	20	5	3.175	20.6	17.324	2.5x1	38	837	1733	44	87	27	67	55	5.5	9.5	5.5		
20-5B2				20.6	17.324	2.5x2	76	1519	3465	44	117	27	67	55	5.5	9.5	5.5		
20-6B1		6	3.969	20.8	16.744	2.5x1	40	1139	2187	48	95	29	71	59	5.5	9.5	5.5		
20-6C1				20.8	16.744	3.5x1	55	1512	3041	48	107	29	71	59	5.5	9.5	5.5		
25-5B1	25	5	3.175	25.6	22.324	2.5x1	46	939	2209	50	86	28	73	61	5.5	9.5	5.5		
25-5B2				25.6	22.324	2.5x2	90	1704	4417	50	116	28	73	61	5.5	9.5	5.5		
25-5C1		6	3.969	25.6	22.324	3.5x1	68	1252	3085	50	96	28	73	61	5.5	9.5	5.5		
25-6B2				25.8	21.744	2.5x2	94	2308	5523	56	131	29	82	69	5.5	9.5	5.5		
25-6C1	25.8	21.744	3.5x1	66	1690	3844	56	107	29	82	69	5.5	9.5	5.5	5.5				
32-5B1	32	5	3.175	32.6	29.324	2.5x1	55	1039	2833	58	91	33	85	71	6.6	11	6.5		
32-5B2				32.6	29.324	2.5x2	109	1886	5666	58	121	33	85	71	6.6	11	6.5		
32-6B1		6	3.969	32.8	28.744	2.5x1	57	1409	3510	62	95	29	89	75	6.6	11	6.5		
32-6B2				32.8	28.744	2.5x2	112	2556	7020	62	131	29	89	75	6.6	11	6.5		
32-8B1	8	4.763	4.763	33	28.132	2.5x1	58	1810	4227	66	125	39	100	82	9	14	8.5		
32-8B2				33	28.132	2.5x2	115	3284	8453	66	173	39	100	82	9	14	8.5		
32-10B1				10	6.350	33.4	26.91	2.5x1	58	2651	5600	74	185	38	108	90	9	14	8.5
32-10B2						33.4	26.91	2.5x2	118	4810	11199	74	208	38	108	90	9	14	8.5
32-10C1	33.4	26.91	3.5x1	86	3519	7785	74	168	38	108	90	9	14	8.5	8.5				
40-5B1	40	5	3.175	40.6	37.324	2.5x1	65	1141	3567	68	96	38	101	83	9	14	8.5		
40-5B2				40.6	37.324	2.5x2	132	2071	7134	68	126	38	101	83	9	14	8.5		
40-6B1		6	3.969	40.8	36.744	2.5x1	67	1552	4428	70	101	35	104	86	9	14	8.5		
40-6B2				40.8	36.744	2.5x2	136	2817	8855	70	137	35	104	86	9	14	8.5		
40-8B1	8	4.763	4.763	41	36.132	2.5x1	69	2003	5302	74	125	39	108	90	9	14	8.5		
40-8B2				41	36.132	2.5x2	137	3634	10603	74	173	39	108	90	9	14	8.5		
40-10B1				10	6.350	41.4	34.91	2.5x1	72	2959	7069	84	158	48	124	102	11	17.5	11
40-10B2						41.4	34.91	2.5x2	145	5370	14138	84	218	48	124	102	11	17.5	11
40-10C1	41.4	34.91	3.5x1	102	3932	9841	84	178	48	124	102	102	11	17.5	11				
40-12B1	12	7.144	7.144	41.6	34.299	2.5x1	70	3425	7837	86	174	48	128	106	11	17.5	11		
40-12B2				41.6	34.299	2.5x2	141	6217	15674	86	246	48	128	106	11	17.5	11		

Remark : Stiffness values listed above are derived from theoretical formula while preload is 10% of dynamic load rating.



**P F D W TYPE 1**

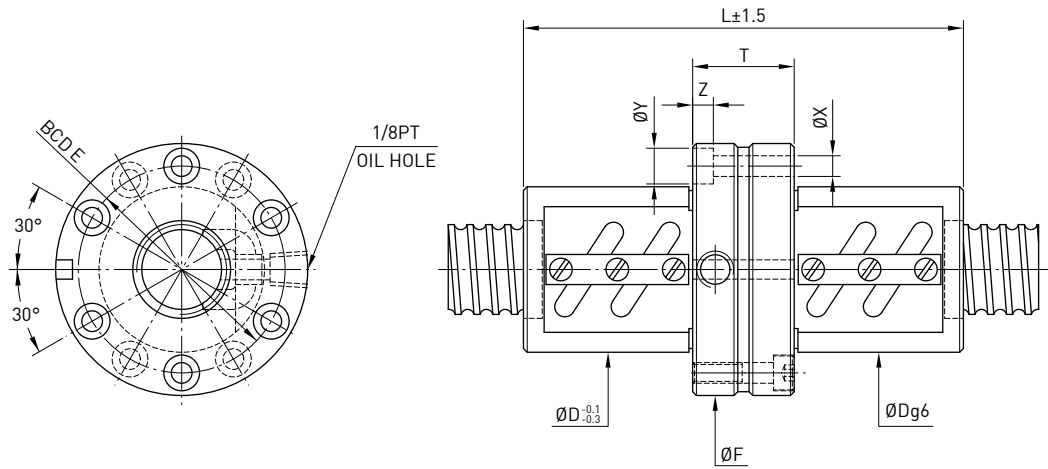

Model	Size		Ball Dia.	PCD	RD	Circuits	Stiffness kgf / $\mu\text{m}$ K	Dynamic Load $1 \times 10^6$ revs C (kgf)	Static Load Co (kgf)	Nut		Flange			Bolt		
	Nominal Dia.	Lead								D	L	T	F	BCD-E	X	Y	Z
50-8B1	50	8	4.763	51	46.132	2.5x1	81	2206	6705	87	133	47	129	107	11	17.5	11
50-8B2				51	46.132	2.5x2	165	4004	13409	87	181	47	129	107	11	17.5	11
50-10B1		10	6.350	51.4	44.91	2.5x1	87	3264	8835	94	158	48	135	113	11	17.5	11
50-10B2				51.4	44.91	2.5x2	173	5923	17670	94	218	48	135	113	11	17.5	11
50-12B2		12	7.938	51.8	43.688	2.5x2	178	8022	22094	102	260	58	146	122	14	20	13
50-12C1					51.8	43.688	3.5x1	123	5875	15380	102	200	58	146	122	14	20
63-10B2	63	10	6.350	64.4	57.91	2.5x2	206	6533	22371	110	228	58	154	130	14	20	13
63-10B3				64.4	57.91	2.5x3	305	9258	33556	110	288	58	154	130	14	20	13
63-12B2		12	7.938	64.8	56.688	2.5x2	214	8943	28062	118	260	58	166	141	14	20	13
80-12B2	81.8				73.688	2.5x2	257	9797	35422	136	260	58	185	159	14	20	13
80-12B3	80	20	9.525	81.8	73.688	2.5x3	380	13884	53132	136	340	58	185	159	14	20	13
80-20B2				82.2	72.466	2.5x2	338	16485	58851	145	404	66	204	172	18	26	17.5
100-20B2	100	20	9.525	102.2	92.466	2.5x2	400	18123	74425	170	404	86	243	205	22	32	21.5

Remark : Stiffness values listed above are derived from theoretical formula while preload is 10% of dynamic load rating.

**P F D W TYPE 2**

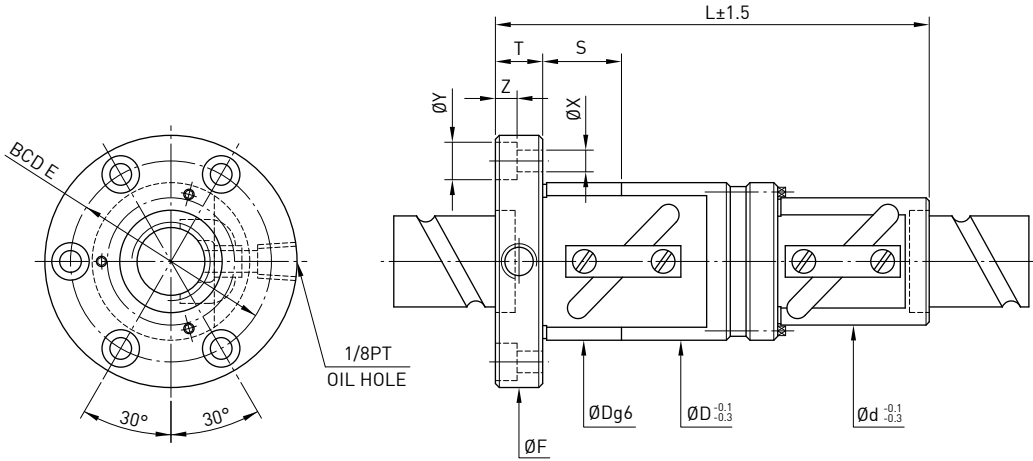

Model	Size		Ball Dia.	PCD	RD	Circuits	Stiffness kgf / $\mu\text{m}$ K	Dynamic Load $1 \times 10^6$ revs C (kgf)	Static Load Co (kgf)	Nut			Flange			Bolt			Fit	
	Nominal Dia.	Lead								D	d	L	F	T	BCD-E	X	Y	Z		S
20-20A1	20	20	3.969	20.8	16.744	1.5x1	26	719	1281	48	36	140	72	12	59	5.5	9.5	5.5	24	
25-16B1	25	16	4.763	26	21.132	2.5x1	56	1592	3237	62	45	148	89	16	75	6.6	11	6.5	24	
25-20B1		20		26	21.132	2.5x1	56	1592	3237	62	45	178	89	16	75	6.6	11	6.5	24	
25-25A1	25	26		21.132	1.5x1	32	1019	1927	62	45	166	89	16	75	6.6	11	6.5	24		
32-20B1	32	20		33	28.132	2.5x1	66	1810	4227	68	54	181	102	16	84	9	14	8.5	30	
32-25B1		25		33	28.132	2.5x1	66	1810	4227	68	54	218	102	16	84	9	14	8.5	30	
32-32A1		32		33	28.132	1.5x1	36	1154	2505	68	54	205	102	16	84	9	14	8.5	30	
40-25B1	40	25	6.350	41.4	34.91	2.5x1	78	2959	7069	84	65	224	126	18	104	11	17.5	11	30	
40-32B1		32		41.4	34.91	2.5x1	78	2959	7069	84	65	276	126	18	104	11	17.5	11	30	
40-40A1		40		41.4	34.91	1.5x1	48	1875	4159	84	65	274	126	18	104	11	17.5	11	30	
50-40A1	50	40		7.938	51.8	43.688	1.5x1	54	2801	6499	106	82	264	152	22	128	13	20	13	40
50-50A1		50			51.8	43.688	1.5x1	60	2801	6499	106	82	320	152	22	128	13	20	13	40

Remark : Stiffness values listed above are derived from theoretical formula while preload is 10% of dynamic load rating.

**P F D W TYPE**

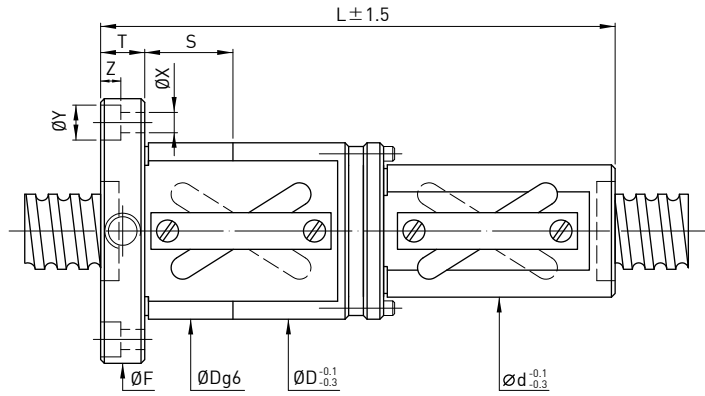
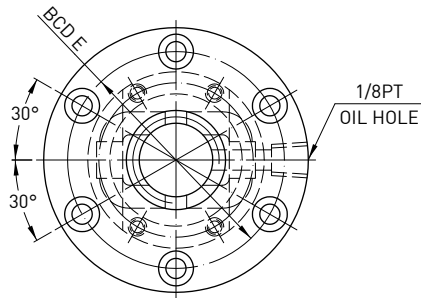

Model	Nominal Dia.	Lead	Circuits	Nut Type	Dynamic Load $1 \times 10^6$ revs C (kgf)	Static Load Co (kgf)	Ball Dia.	Start type	D	d	L	F	T	BCD-E	X	Y	Z	S
36-20B2	36	20	2.5x2	PFDW	5447	13597	6.35	2	94	76	191	136	18	114	11	17.5	11	30
40-25B2	40	25	2.5x2	PFDW	6743	17002	7.144	2	98	80	230	140	18	118	11	17.5	11	30
40-30B2		30	2.5x2	PFDW	6743	17002	7.144	2	98	80	250	140	18	118	11	17.5	11	30
40-32B3	45	32	2.5x3	PFDW	7771	21823	6.35	3	96	78	270	142	22	118	13	20	13	30
45-25B2		25	2.5x2	PFDW	6991	19186	7.144	2	101	83	230	143	18	121	11	17.5	11	30
45-30B2	50	30	2.5x2	PFDW	6991	19186	7.144	2	101	83	250	143	18	121	11	17.5	11	30
45-32B3		32	2.5x3	PFDW	7857	24730	6.35	3	98	80	270	144	22	120	13	20	13	30
50-25B2	55	25	2.5x2	PFDW	7033	21370	7.144	2	103	85	230	145	18	123	11	17.5	11	40
50-30B2		30	2.5x2	PFDW	7033	21370	7.144	2	103	85	250	145	18	123	11	17.5	11	40
50-32B3	55	32	2.5x3	PFDW	8148	27525	6.35	3	101	83	270	147	22	123	13	20	13	40
55-25B2		25	2.5x2	PFDW	7518	23553	7.144	2	105	87	230	147	18	125	11	17.5	11	40
55-30B2	55	30	2.5x2	PFDW	7518	23553	7.144	2	105	87	250	147	18	125	11	17.5	11	40
55-32B3		32	2.5x3	PFDW	8332	30207	6.35	3	103	85	270	149	22	125	13	20	13	40

Remark : Stiffness values listed above are derived from theoretical formula while preload is 10% of dynamic load rating.

**P F D I TYPE**

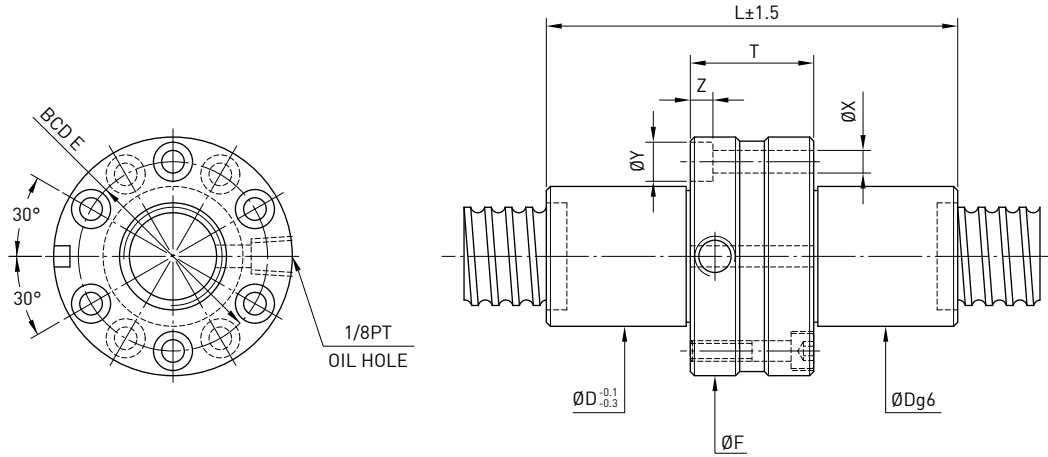

Model	Size		Ball Dia.	PCD	RD	Circuits	Stiffness kgf / $\mu$ m K	Dynamic Load $1 \times 10^6$ revs C (kgf)	Static Load Co (kgf)	Flange					Bolt		
	Nominal Dia.	Lead								D	L	F	T	BCD-E	X	Y	Z
20-5T3	20	5	3.175	20.6	17.324	3	39	852	1767	34	100	58	30	46	5.5	9.5	5.5
20-5T4				20.6	17.324	4	54	1091	2356	34	110	58	30	46	5.5	9.5	5.5
20-6T3		6	3.969	20.8	16.744	3	39	1091	2081	36	111	58	29	46	5.5	9.5	5.5
20-6T4				20.8	16.744	4	54	1398	2774	36	127	58	29	46	5.5	9.5	5.5
25-5T3	25	5	3.175	25.6	22.324	3	55	977	2314	40	100	63	30	51	5.5	9.5	5.5
25-5T4				25.6	22.324	4	73	1252	3085	40	110	63	30	51	5.5	9.5	5.5
25-6T3		6	3.969	25.8	21.744	3	56	1272	2762	40	111	63	29	51	5.5	9.5	5.5
25-6T4				25.8	21.744	4	75	1628	3682	40	127	63	29	51	5.5	9.5	5.5
32-5T3	32	5	3.175	32.6	29.324	3	64	1117	3081	48	100	75	30	61	6.6	11	6.5
32-5T4				32.6	29.324	4	82	1431	4108	48	110	75	30	61	6.6	11	6.5
32-6T3		6	3.969	32.8	28.744	3	65	1446	3620	50	111	75	29	61	6.6	11	6.5
32-6T4				32.8	28.744	4	84	1852	4826	50	127	75	29	61	6.6	11	6.5
32-8T3		8	4.763	33	28.132	3	68	1810	4227	52	139	84	35	68	9	14	8.5
32-8T4				33	28.132	4	82	2317	5635	52	157	84	35	68	9	14	8.5
32-10T3	10	6.350	33.4	26.91	3	68	2539	5327	56	165	88	35	70	9	14	8.5	
32-10T4			33.4	26.91	4	82	3252	7102	56	185	88	35	70	9	14	8.5	
40-5T4	40	5	3.175	40.6	37.324	4	99	1599	5280	54	115	90	35	72	9	14	8.5
40-5T6				40.6	37.324	6	146	2265	7919	54	135	90	35	72	9	14	8.5
40-6T4		6	3.969	40.8	36.744	4	100	2136	6420	56	133	90	35	72	9	14	8.5
40-6T6				40.8	36.744	6	148	3028	9630	56	157	90	35	72	9	14	8.5
40-8T4		8	4.763	41	36.132	4	102	2728	7596	60	157	94	35	76	9	14	8.5
40-8T6				41	36.132	6	150	3866	11394	60	191	94	35	76	9	14	8.5
40-10T3		10	6.350	41.4	34.91	3	76	2529	7069	62	175	104	45	82	11	17.5	11
40-10T4				41.4	34.91	4	101	3789	9426	62	195	104	45	82	11	17.5	11
50-5T4	50	5	3.175	50.6	47.324	4	121	1757	6745	65	115	100	35	82	9	14	8.5
50-5T6				50.6	47.324	6	177	2490	10117	65	135	100	35	82	9	14	8.5
50-6T4		6	3.969	50.8	46.744	4	123	2388	8250	68	136	100	38	82	9	14	8.5
50-6T6				50.8	46.744	6	179	3384	12375	68	160	100	38	82	9	14	8.5
50-8T4		8	4.763	51	46.132	4	122	2998	9578	70	165	112	43	90	11	17.5	11
50-8T6				51	46.132	6	178	4249	14367	70	199	112	43	90	11	17.5	11
50-10T3		10	6.350	51.4	44.91	3	95	3397	9256	74	175	114	45	92	11	17.5	11
50-10T4				51.4	44.91	4	124	4350	12341	74	195	114	45	92	11	17.5	11
50-10T6		10	6.350	51.4	44.91	6	184	6165	18511	74	235	114	43	92	11	17.5	11
50-12T3				12	7.938	51.8	43.688	3	94	4420	11047	75	203	121	49	97	14
50-12T4		51.8	43.688			4	124	5660	14730	75	227	121	49	97	14	20	13

Remark : Stiffness values listed above are derived from theoretical formula while preload is 10% of dynamic load rating.

**P F D I TYPE**

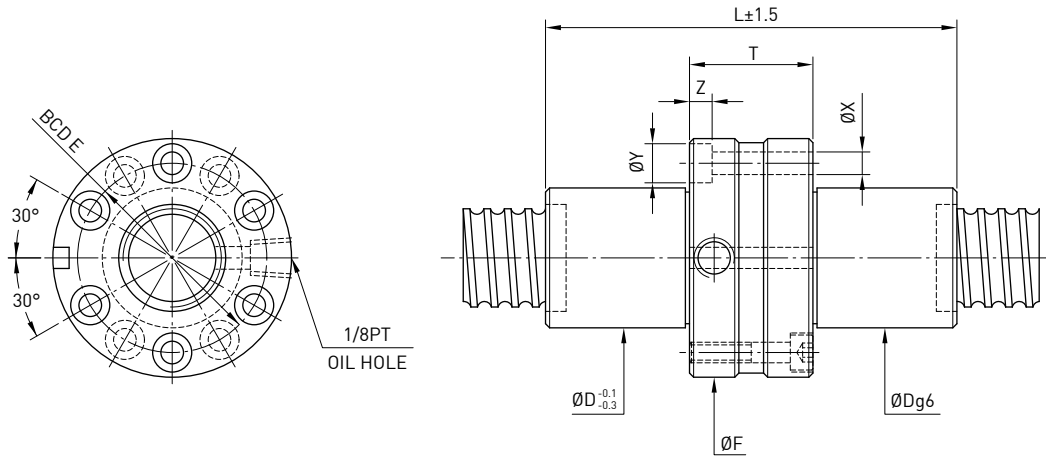

Model	Size		Ball Dia.	PCD	RD	Circuits	Stiffness kgf / $\mu\text{m}$ K	Dynamic Load $1 \times 10^6$ revs C (kgf)	Static Load Co (kgf)	Flange				Bolt			
	Nominal Dia.	Lead								D	L	F	T	BCD-E	X	Y	Z
63-6T4	63	6	3.969	63.8	59.744	4	148	2614	10542	80	142	122	44	100	11	17.5	11
63-6T6				63.8	59.744	6	220	3704	15813	80	166	122	44	100	11	17.5	11
63-8T4		8	4.763	64	59.132	4	152	3395	12541	82	165	124	43	102	11	17.5	11
63-8T6				64	59.132	6	222	4812	18811	82	199	124	43	102	11	17.5	11
63-10T4		10	6.350	64.4	57.91	4	158	4860	15858	85	205	131	55	107	14	20	13
63-10T6				64.4	57.91	6	228	6887	23786	85	245	131	53	107	14	20	13
63-12T4	12	7.938	64.8	56.688	4	152	6479	19293	90	230	136	52	112	14	20	13	
63-12T6			64.8	56.688	6	224	9182	28939	90	280	136	52	112	14	20	13	
80-10T4	80	10	6.350	81.4	74.91	4	190	5559	21118	105	205	151	55	127	14	20	13
80-10T6				81.4	74.91	6	277	7879	31677	105	245	151	53	127	14	20	13
80-12T4		12	7.938	81.8	73.688	4	192	7430	25681	110	230	156	52	132	14	20	13
80-12T6				81.8	73.688	6	280	10530	38521	110	280	156	52	132	14	20	13
80-20T3		20	9.525	82.2	72.466	3	189	9663	31622	115	301	173	65	143	18	26	17.5
80-20T4				82.2	72.466	4	248	12375	42162	115	346	173	66	143	18	26	17.5
100-10T6	100	10	6.350	101.4	94.91	6	236	8662	40469	125	245	171	53	147	14	20	13
100-12T6		12	9.525	102.2	92.466	6	343	19230	79741	130	292	188	64	158	18	26	17.5
100-20T4		20	9.525	102.2	92.466	4	300	13569	53161	135	356	205	76	169	22	32	21.5

Remark : Stiffness values listed above are derived from theoretical formula while preload is 10% of dynamic load rating.

**O F S W TYPE**

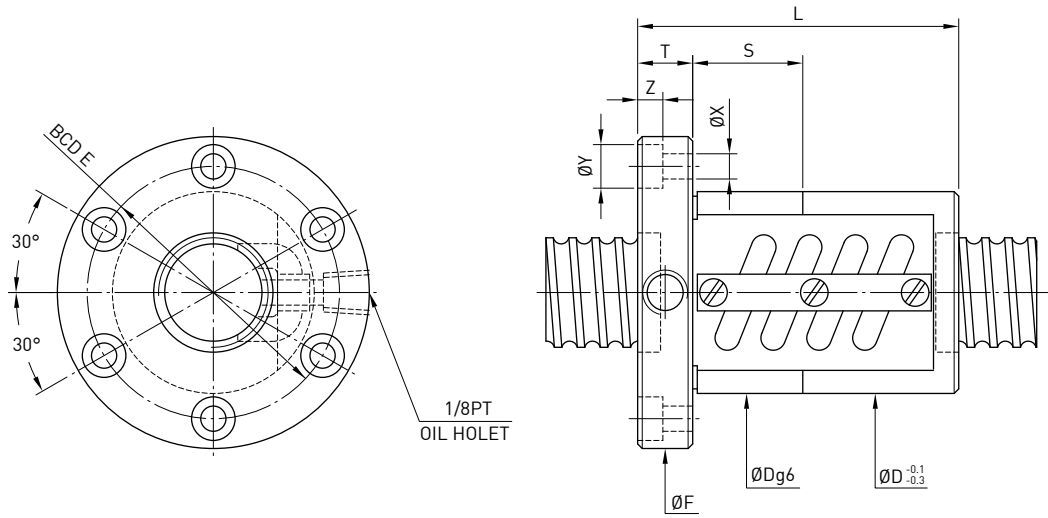

Model	Size		Ball Dia.	PCD	RD	Circuits	Stiffness kgf / $\mu\text{m}$ K	Dynamic Load $1 \times 10^6$ revs C (kgf)	Static Load Co (kgf)	Nut		Flange			Bolt			Fit
	Nominal Dia.	Lead								D	L	F	T	BCD-E	X	Y	Z	
16-5B1	16	5	3.175	16.6	13.324	2.5x1	32	763	1400	40	58	64	12	51	5.5	9.5	5.5	24
16-5A1				16.6	13.324	1.5x1	20	482	820	40	50	64	12	51	5.5	9.5	5.5	24
20-5B1	20	5	3.175	20.6	17.324	2.5x1	38	837	1733	44	60	68	12	55	5.5	9.5	5.5	24
20-5A2				20.6	17.324	1.5x2	46	979	2079	44	70	68	12	55	5.5	9.5	5.5	24
20-6B1	20	6	3.969	20.8	16.744	2.5x1	40	1139	2187	48	69	72	12	59	5.5	9.5	5.5	24
25-4B1				25	4	2.381	25.25	22.792	2.5x1	38	544	1376	46	48	69	11	57	5.5
25-4B2	25.25	22.792	2.5x2				74	988	2752	46	72	69	11	57	5.5	9.5	5.5	12
25-5B1	25	5	3.175	25.6	22.324	2.5x1	46	939	2209	50	60	74	12	62	5.5	9.5	5.5	24
25-5A2				25.6	22.324	1.5x2	48	1078	2594	50	70	74	12	62	5.5	9.5	5.5	24
25-5C1	25	5	3.175	25.6	22.324	3.5x1	68	1252	3085	50	72	74	12	62	5.5	9.5	5.5	24
25-6A2				25	6	3.969	25.8	21.744	1.5x2	56	1462	3249	56	82	82	12	69	6.6
25-6C1	25.8	21.744	3.5x1				66	1690	3844	56	81	82	12	69	6.6	11	6.5	24
25-10A1	25	10	4.763	26	21.132	1.5x1	29	1019	1927	60	81	86	16	73	6.6	11	6.5	24
28-5B1				28	5	3.175	28.6	25.324	2.5x1	51	984	2466	55	60	85	12	69	6.6
28-5B2	28.6	25.324	2.5x2				98	1785	4932	55	96	85	12	69	6.6	11	6.5	24
28-6A2	28	6	3.175	28.6	25.324	1.5x2	59	1150	2960	55	80	85	12	69	6.6	11	6.5	24
32-5B1				32	5	3.175	32.6	29.324	2.5x1	55	1039	2833	58	62	84	12	71	6.6
32-5A2	32.6	29.324	1.5x2				65	1216	3400	58	70	84	12	71	6.6	11	6.5	24
32-5C1	32	5	3.175	32.6	29.324	3.5x1	76	1388	3967	58	72	84	12	71	6.6	11	6.5	24
32-6B1				32	6	3.969	32.8	28.744	2.5x1	57	1409	3510	62	70	88	12	75	6.6
32-6A2	32.8	28.744	1.5x2				67	1633	4168	62	81	88	12	75	6.6	11	6.5	24
32-6C1	32	6	3.969	32.8	28.744	3.5x1	78	1888	4936	62	83	88	12	75	6.6	11	6.5	24
32-8B1				32	8	4.763	33	28.132	2.5x1	58	1810	4227	66	92	100	16	82	9
32-8A2	33	28.132	1.5x2				69	2094	5009	66	106	100	16	82	9	14	8.5	30
32-8C1	32	8	4.763	33	28.132	3.5x1	82	2428	5948	66	108	100	16	82	9	14	8.5	30
32-10B1				32	10	6.350	33.4	26.91	2.5x1	58	2651	5600	74	110	108	16	90	9
32-10A1	33.4	26.91	1.5x1				36	1673	3278	74	90	108	16	90	9	14	8.5	30
32-12A1	32	12	6.350	33.4	26.91	1.5x1	37	1672	3278	74	97	108	18	90	9	14	8.5	15
32-12B1				33.4	26.91	2.5x1	61	2650	5599	74	117	108	18	90	9	14	8.5	15

Remark : Stiffness values listed above are derived from theoretical formula while preload is 10% of dynamic load rating.

**O F S W TYPE**

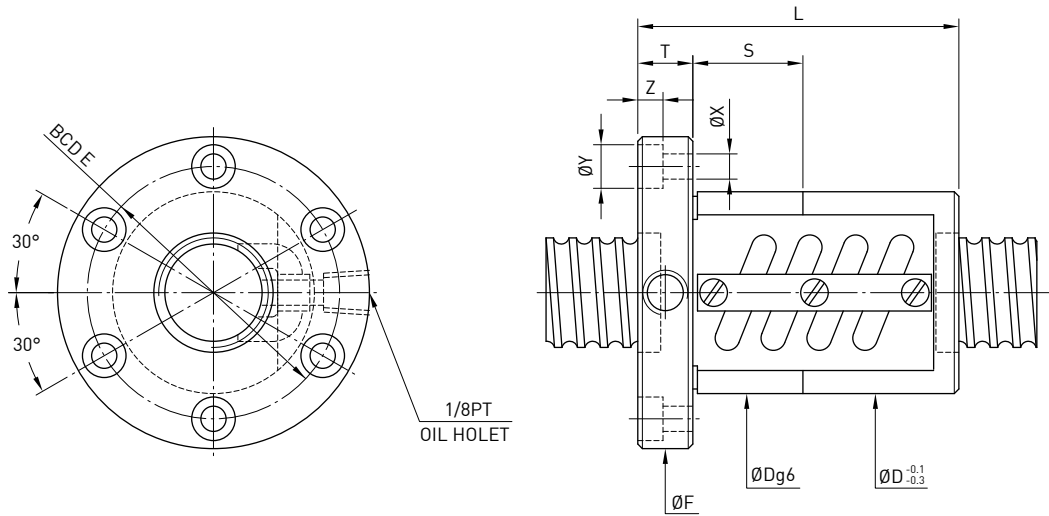

Model	Size		Ball Dia.	PCD	RD	Circuits	Stiffness kgf / $\mu\text{m}$ K	Dynamic Load $1 \times 10^6$ revs C (kgf)	Static Load Co (kgf)	Nut		Flange			Bolt			Fit
	Nominal Dia.	Lead								D	L	F	T	BCD-E	X	Y	Z	
36-6B1	36	6	3.175	36.6	33.324	2.5x1	62	1486	3969	65	68	100	12	82	6.6	11	6.5	24
36-6B2				36.6	33.324	2.5x2	121	2696	7937	65	103	100	12	82	6.6	11	6.5	24
36-10A1		10	6.350	37.4	30.91	1.5x1	40	1779	3718	75	90	120	18	98	11	17.5	11	30
36-16B1		16		37.4	30.91	2.5x1	67	2812	6334	74	136	114	18	90	9	14	8.5	15
40-5B1	40	5	3.175	40.6	37.324	2.5x1	65	1141	3567	68	65	102	16	84	9	14	8.5	30
40-5B2				40.6	37.324	2.5x2	132	2071	7134	68	95	102	16	84	9	14	8.5	30
40-6B2		6	3.969	40.8	36.744	2.5x2	136	2817	8855	70	109	104	16	86	9	14	8.5	30
40-8B1		8		41	36.132	2.5x1	69	2003	5302	74	90	108	16	90	9	14	8.5	30
40-8C1			41	36.132	3.5x1	96	2679	7438	74	108	108	16	90	9	14	8.5	30	
40-10B1		10	6.350	41.4	34.91	2.5x1	72	2959	7069	84	110	125	18	104	11	17.5	11	30
40-10C1				41.4	34.91	3.5x1	102	3932	9841	84	132	125	18	104	11	17.5	11	30
40-12B1		12	7.144	41.6	34.299	2.5x1	72	3425	7837	86	117	128	18	106	11	17.5	11	40
40-16A1	16	41.6		34.299	1.5x1	46	2208	4703	86	117	128	18	106	11	17.5	11	40	
45-10B1	45	10	6.350	46.4	39.91	2.5x1	76	3111	7953	88	110	132	18	110	11	17.5	11	30
45-12B1		12	7.938	46.8	38.688	2.5x1	81	4202	9900	96	132	142	22	117	13	20	13	40
50-5A2	50	5	3.175	50.6	47.324	1.5x2	96	1447	5382	80	74	114	16	96	9	14	8.5	30
50-5A3				50.6	47.324	1.5x3	143	2051	8072	80	103	114	16	96	9	14	8.5	30
50-6B2		6	3.969	50.8	46.744	2.5x2	161	3093	11149	84	110	118	16	100	9	14	8.5	30
50-8B1		8		51	46.132	2.5x1	81	2206	6705	87	92	128	18	107	11	17.5	11	30
50-8B2			51	46.132	2.5x2	165	4004	13409	87	140	128	18	107	11	17.5	11	30	
50-10B2		10	6.350	51.4	44.91	2.5x2	173	5923	17670	94	170	135	18	114	11	17.5	11	30
50-10C1				51.4	44.91	3.5x1	120	4393	12481	94	130	135	18	114	11	17.5	11	30
50-12B1		12	7.938	51.8	43.688	2.5x1	123	4420	11047	102	132	150	22	125	13	20	13	40
55-10C1	55	10	6.350	56.4	49.91	3.5x1	132	4562	13661	100	130	140	18	118	11	17.5	11	40
55-12B1		12	7.938	56.8	48.688	2.5x1	128	4624	12195	105	132	154	22	127	13	20	13	40
63-8A2	63	8	4.763	64	59.132	1.5x2	107	2826	10129	104	108	146	18	124	11	17.5	11	40
63-10B2		10	6.350	64.4	57.91	2.5x2	206	6533	22371	110	172	152	20	130	11	17.5	11	40
63-12B1		12	7.938	64.8	56.688	2.5x1	107	4927	14031	118	135	166	22	141	13	20	13	40
63-16B1		16	9.525	65.2	55.466	2.5x1	140	8189	23005	124	158	172	22	147	13	20	13	40
63-20A1		20		65.2	55.466	1.5x1	84	5306	13890	124	147	172	22	147	13	20	13	40
70-10B1	70	10	6.350	71.4	64.91	2.5x1	114	3770	12506	124	112	170	20	145	13	20	13	40
70-12B1		12	7.938	71.8	63.688	2.5x1	118	5169	15638	130	132	178	22	152	13	20	13	40

Remark : Stiffness values listed above are derived from theoretical formula while preload is 10% of dynamic load rating.

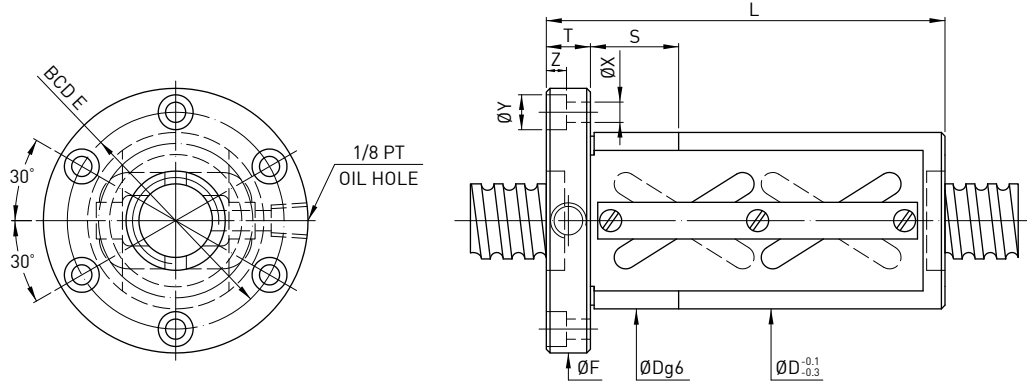
**O F S W TYPE**

Model	Nominal Dia.	Lead	Circuits	Nut Type	Dynamic Load 1x10 <sup>6</sup> revs C (kgf)	Static Load Co (kgf)	Ball Dia.	Start type	D	L	F	T	BCD-E	X	Y	Z	S
36-20C1	36	20	3.5x1	OFSW	4478	10201	6.35	2	94	121	136	18	114	11	17.5	11	30
40-20C1	40	20	3.5x1	OFSW	4810	11367	6.35	2	96	121	138	18	116	11	17.5	11	30
40-20B2		20	2.5x2	OFSW	6537	16238	6.35	2	96	161	138	18	116	11	17.5	11	30
45-20C1	45	20	3.5x1	OFSW	4845	12823	6.35	2	98	122	140	18	118	11	17.5	11	30
45-20B2		20	2.5x2	OFSW	6585	18318	6.35	2	98	162	140	18	118	11	17.5	11	30
45-25C1	50	25	3.5x1	OFSW	5501	19186	7.144	2	101	141	143	18	121	11	17.5	11	30
50-20C1		20	3.5x1	OFSW	5027	14278	6.35	2	101	122	143	18	121	11	17.5	11	40
50-20B2	50	20	2.5x2	OFSW	6831	20397	6.35	2	101	162	143	18	121	11	17.5	11	40
50-25C1		25	3.5x1	OFSW	5782	16033	7.144	2	103	141	145	18	123	11	17.5	11	40
50-30C1	55	30	3.5x1	OFSW	5782	16033	7.144	2	103	160	145	18	123	11	17.5	11	40
55-20C1		20	3.5x1	OFSW	5158	15733	6.35	2	103	122	145	18	123	11	17.5	11	40
55-20B2	55	20	2.5x2	OFSW	7009	22476	6.35	2	103	162	145	18	123	11	17.5	11	40
55-25C1		25	3.5x1	OFSW	6181	17670	7.144	2	105	141	147	18	125	11	17.5	11	40
55-30C1	55	30	3.5x1	OFSW	6181	17670	7.144	2	105	160	147	18	125	11	17.5	11	40



**O F S I TYPE**

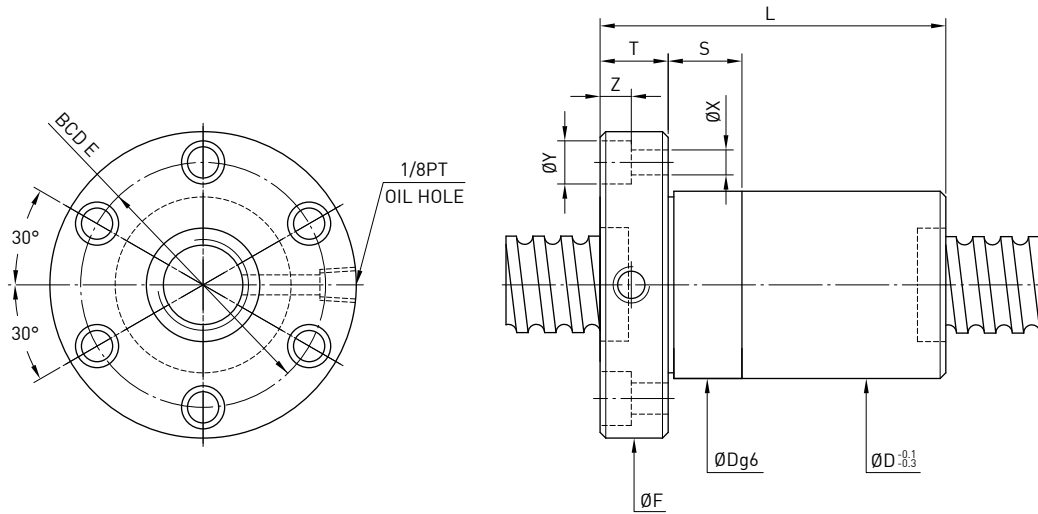

Model	Size		Ball Dia.	PCD	RD	Circuits	Stiffness kgf / $\mu\text{m}$ K	Dynamic Load $1 \times 10^6$ revs C (kgf)	Static Load Co (kgf)	Nut		Flange			Bolt			Fit
	Nominal Dia.	Lead								D	L	F	T	BCD-E	X	Y	Z	
20-5T3	20	5	3.175	20.6	17.324	3x2	39	852	1767	34	67	57	12	45	5.5	9.5	5.5	24
20-6T3		6	3.969	20.8	16.744	3x2	39	1091	2081	36	77	60	12	48	5.5	9.5	5.5	24
25-5T3	25	5	3.175	25.6	22.324	3x2	55	977	2314	40	67	64	12	52	5.5	9.5	5.5	24
25-6T3		6	3.969	25.8	21.744	3x2	56	1272	2762	42	77	65	12	53	5.5	9.5	5.5	24
32-5T3	32	5	3.175	32.6	29.324	3x2	64	1117	3081	48	67	74	12	60	6.5	11	6.5	24
32-5T4				32.6	29.324	4x2	82	1431	4108	48	77	74	12	60	6.5	11	6.5	24
32-6T3		6	3.969	32.8	28.744	3x2	65	1446	3620	50	67	76	12	62	6.5	11	6.5	24
32-6T4				32.8	28.744	4x2	84	1852	4826	50	90	76	12	62	6.5	11	6.5	24
32-8T3		8	4.763	33	28.132	3x2	68	1810	4227	52	100	78	16	64	6.6	11	6.5	24
32-8T4				33	28.132	4x2	82	2317	5635	52	117	78	16	64	6.6	11	6.5	24
32-10T3	10	6.350	33.4	26.91	3x2	68	2539	5327	56	120	82	16	68	6.6	11	6.5	24	
36-8T4	36	8	4.763	37	32.132	4	88	2531	6614	56	116	86	15	70	9	14	8.5	25
40-5T4	40	5	3.175	40.6	37.324	4x2	99	1599	5280	54	81	80	16	66	6.6	11	6.5	24
40-5T6				40.6	37.324	6x2	146	2265	7919	54	102	80	16	66	6.6	11	6.5	24
40-6T4		6	3.969	40.8	36.744	4x2	100	2136	6420	56	94	88	16	72	9	14	8.5	30
40-6T6				40.8	36.744	6x2	148	3028	9630	56	119	88	16	72	9	14	8.5	30
40-8T4		8	4.763	41	36.132	4x2	102	2728	7596	60	117	92	16	75	9	14	8.5	30
40-10T3		10	6.350	41.4	34.91	3x2	76	2959	7069	65	123	96	16	80	9	14	8.5	30
40-10T4			41.4	34.91	4x2	101	3789	9426	65	143	96	16	80	9	14	8.5	30	
50-5T4	50	5	3.175	50.6	47.324	4x2	121	1757	6745	65	81	96	16	80	9	14	8.5	30
50-5T6				50.6	47.324	6x2	177	2490	10117	65	102	96	16	80	9	14	8.5	30
50-6T4		6	3.969	50.8	46.744	4x2	123	2388	8250	68	94	100	16	84	9	14	8.5	30
50-6T6				50.8	46.744	6x2	179	3384	12375	68	119	100	16	84	9	14	8.5	30
50-8T4		8	4.763	51	46.132	4x2	122	2998	9578	70	120	102	16	85	9	14	8.8	30
50-10T3		10	6.350	51.4	44.91	3x2	95	3397	9256	74	123	114	18	92	11	17.5	11	40
50-10T4	51.4			44.91	4x2	124	4350	12341	74	143	114	18	92	11	17.5	11	40	
50-12T3	12	7.938	51.8	43.688	3x2	94	4420	11047	78	147	118	18	96	11	17.5	11	40	
63-6T4	63	6	3.969	63.8	59.744	4x2	148	2614	10542	80	96	119	18	98	11	17.5	11	40
63-6T3				63.8	59.744	3x2	220	3704	15813	80	121	119	18	98	11	17.5	11	40
63-8T4		8	4.763	64	59.132	4x2	152	3395	12541	82	119	122	18	100	11	17.5	11	40
63-10T4				10	6.350	64.4	57.91	4x2	158	4860	15858	88	147	134	20	110	14	20
63-12T3		12	7.938	64.8	56.688	3x2	114	5059	14470	92	150	138	20	114	14	20	13	40

Remark : Stiffness values listed above are derived from theoretical formula while preload is 10% of dynamic load rating.

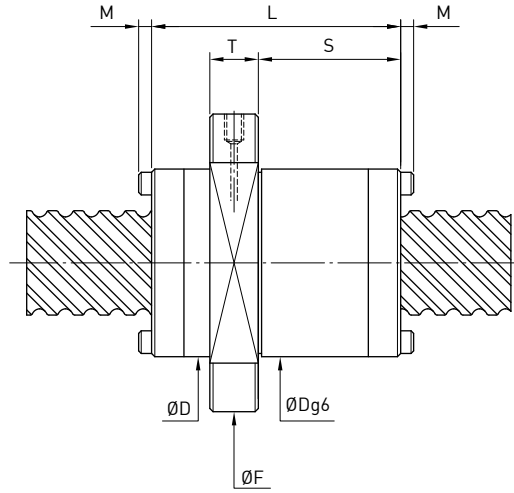
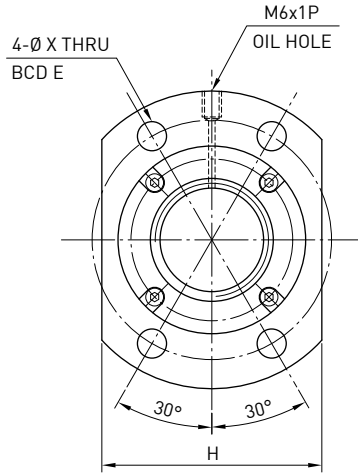
**F S H TYPE**

Model	Size		Ball Dia.	PCD	RD	Circuits	Stiffness kgf / $\mu\text{m}$ K	Dynamic Load $1 \times 10^6$ revs C (kgf)	Static Load Co (kgf)	Nut		Flange				Bolt		Fit	
	Nominal Dia.	Lead								D	L	F	T	BCD-E	H	X	S	M	
15-20S1	15	20	3.175	15.6	12.324	1.8x1	18	540	1030	34	45	55	10	45	36	5.5	24	0	
16-16S2	16	16		16.6	13.324	1.8x2	35	1060	2280	32	48	53	10	42	38	4.5	26	0	
16-16S4				16.6	13.324	1.8x4	68	1930	4560	33	48	58	10	45	38	6.6	26	0	
16-16S2				16.6	13.324	1.8x2	35	1060	2280	33	48	58	10	45	38	6.6	26	0	
16-16S4				16.6	13.324	1.8x4	68	1930	4560	33	48	58	10	45	38	6.6	26	0	
20-20S2	20	20		20.6	17.324	1.8x2	42	1180	2860	39	48	62	10	50	46	5.5	27.5	0	
20-20S2				20.6	17.324	1.8x2	42	1180	2860	38	58	62	10	50	46	5.5	32.5	3	
20-20S4				20.6	17.324	1.8x4	81	2150	5720	38	58	62	10	50	46	5.5	32.5	3	
25-25S2				25	25	25.8	21.744	1.8x2	53	1770	4470	47	67	74	12	60	56	6.6	39.5
25-25S4	25.8	21.744				1.8x4	105	3220	8940	47	67	74	12	60	56	6.6	39.5	3	
32-32S2	32	32	33			28.132	1.8x2	66	2510	6770	58	85	92	15	74	68	9	48	0
32-32S4			33			28.132	1.8x4	128	4550	13540	58	85	92	15	74	68	9	48	0
40-40S2	40	40	6.350	41.4	34.91	1.8x2	82	4130	11450	72	102	114	17	93	84	11	60	0	
40-40S4				41.4	34.91	1.8x4	159	7500	22910	72	102	114	17	93	84	11	60	0	
50-50S2	50	50	7.938	51.8	43.688	1.8x2	100	6170	17900	90	125	135	20	112	104	14	83.5	0	
50-50S4				51.8	43.688	1.8x4	193	11210	35800	90	125	135	20	112	104	14	83.5	0	

Remark : Stiffness values listed above are derived from theoretical formula while preload is 5% of dynamic load rating.

**D F S V TYPE**

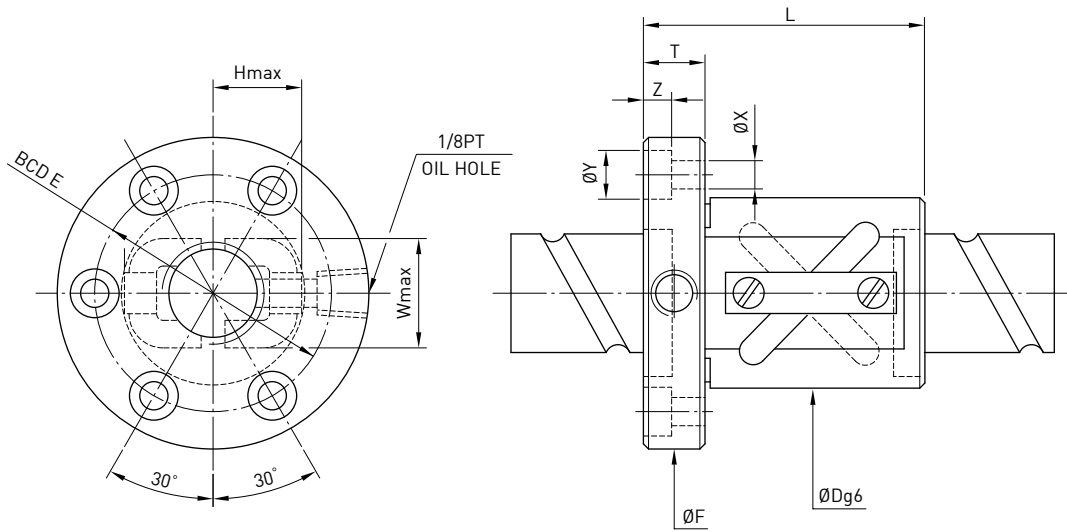

Model	Size		Ball Dia.	PCD	RD	Circuits	Dynamic Load 1x10 <sup>6</sup> revs C (kgf)	Static Load Co (kgf)	Nut		Flange			Return Tube		Bolt		
	Nominal Dia.	Lead							D	L	F	T	BCD-E	W	H	X	Y	Z
16-16A2	16	16	3.175	16.6	13.324	1.5x2	704	1376	32	60	55	12	43	22	22	5.5	9.5	5.5
20-20A2	20	20		20.6	17.324	1.5x2	793	1745	36	69	60	12	47	28	27	5.5	9.5	5.5
25-25A2	25	25	3.969	25.8	21.744	1.5x2	1174	2730	42	69	70	12	55	32	28	6.6	11	6.5
32-32A2	32	32	4.763	33	28.132	1.5x2	1682	4208	54	94	100	15	80	40	37	9	14	8.5
40-40A2	40	40	6.350	41.4	34.91	1.5x2	2806	7222	65	115	106	18	85	52	42	11	17.5	11

## 6.3 Miniature Ground Ballscrew

**F S I** TYPE (SHAFT OD 6, LEAD 1)

◀ Miniature

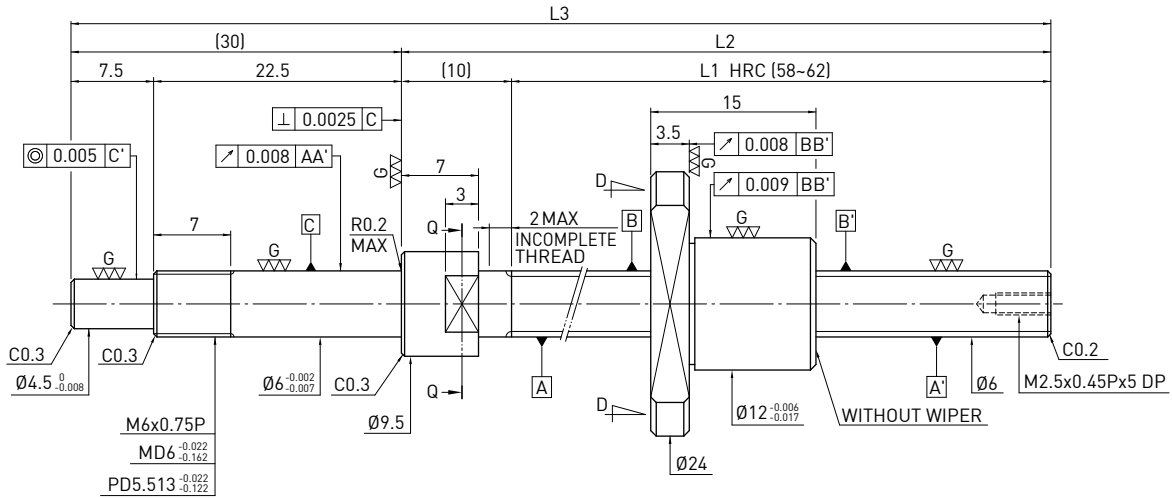

Ball screw Data	
Direction	Right Hand
Lead (mm)	1.0
Lead Angle	2.99°
P.C.D (mm)	6.1
Screw P.C.D (mm)	6.1
RD (mm)	5.261
Steel Ball (mm)	Ø0.8
Circuits	1x3
Dynamic Load C (Kgf)	66
Static Load Co (Kgf)	111
Axial Play (mm)	0      0.005 MAX
Drag Torque (Kgf-cm)	0.13 MAX    0.03 MAX
Spacer Ball	-      -

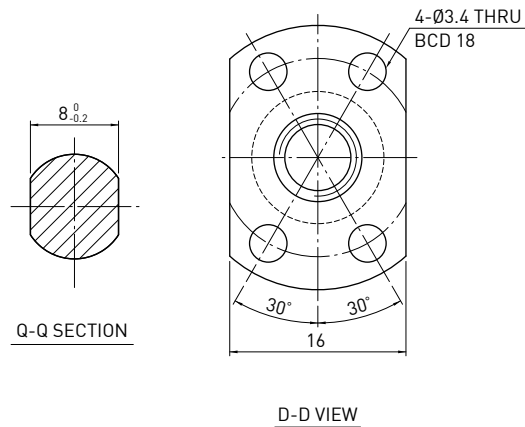

Unit : mm

Stroke	HIWIN Code	L1	L2	L3	Accuracy grade
40	R6-1.0T3-FSI-65-105-0.008	65	75	105	3
70	R6-1.0T3-FSI-95-135-0.008	95	105	135	3
100	R6-1.0T3-FSI-125-165-0.008	125	135	165	3

**F S I TYPE (SHAFT OD 8, LEAD 1)**

◀ Miniature

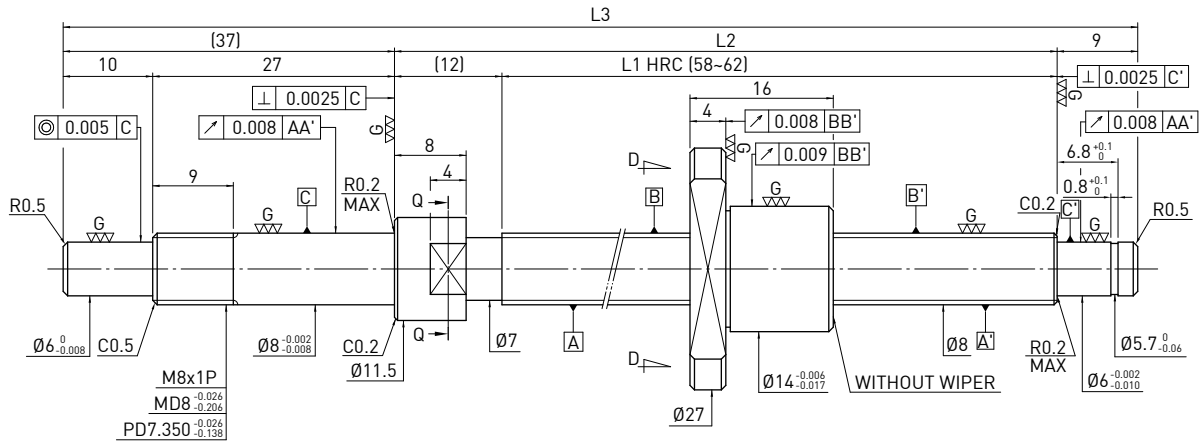

Ball screw Data	
Direction	Right Hand
Lead (mm)	1.0
Lead Angle	2.25°
P.C.D (mm)	8.1
Screw P.C.D (mm)	8.1
RD (mm)	7.261
Steel Ball (mm)	Ø0.8
Circuits	1x3
Dynamic Load C (Kgf)	79
Static Load Co (Kgf)	157
Axial Play (mm)	0      0.005 MAX
Drag Torque (Kgf-cm)	0.18 MAX      0.05 MAX
Spacer Ball	-      -

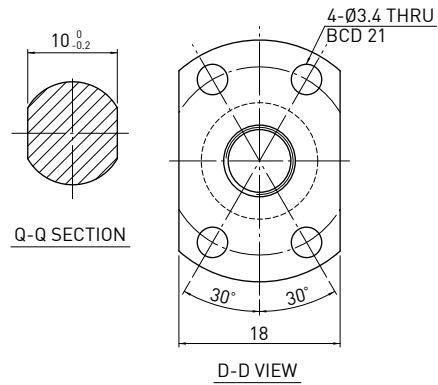

Unit : mm

Stroke	HIWIN Code	L1	L2	L3	Accuracy grade
40	R8-1.0T3-FSI-80-138-0.008	80	92	138	3
70	R8-1.0T3-FSI-110-168-0.008	110	122	168	3
100	R8-1.0T3-FSI-140-198-0.008	140	152	198	3
150	R8-1.0T3-FSI-190-248-0.008	190	202	248	3

**F S I** TYPE (SHAFT OD 8, LEAD 1.5)

◀ Miniature

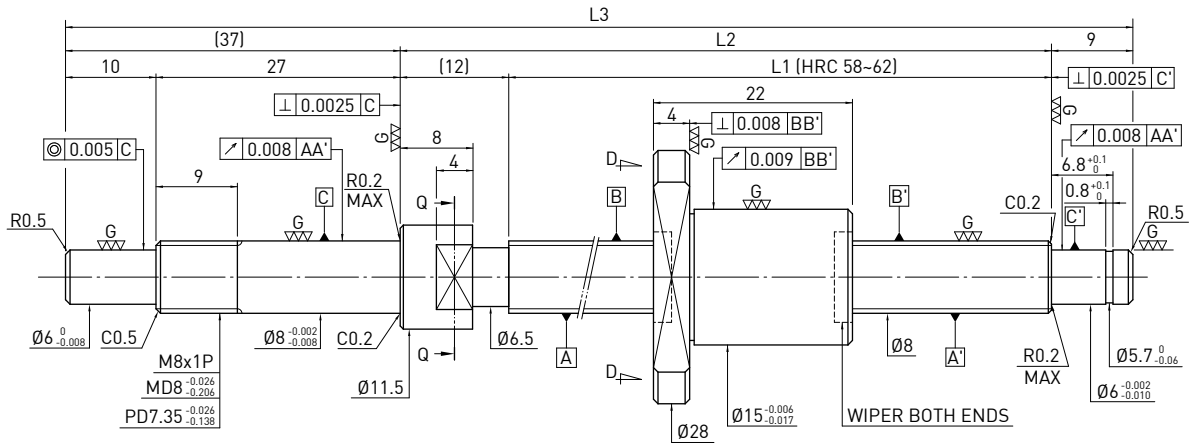

Ball screw Data	
Direction	Right Hand
Lead (mm)	1.5
Lead Angle	3.37°
P.C.D (mm)	8.1
Screw P.C.D (mm)	8.2
RD (mm)	7.15
Steel Ball (mm)	Ø1
Circuits	1x3
Dynamic Load C (Kgf)	105
Static Load Co (Kgf)	191
Axial Play (mm)	0      0.005 MAX
Drag Torque (Kgf-cm)	0.2 MAX      0.05 MAX
Spacer Ball	-      -

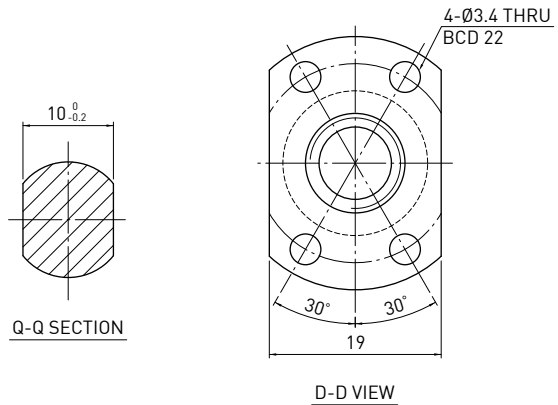

Unit : mm

Stroke	HIWIN Code	L1	L2	L3	Accuracy grade
40	R8-1.5T3-FSI-80-138-0.008	80	92	138	3
70	R8-1.5T3-FSI-110-168-0.008	110	122	168	3
100	R8-1.5T3-FSI-140-198-0.008	140	152	198	3
150	R8-1.5T3-FSI-190-248-0.008	190	202	248	3

**F S I TYPE (SHAFT OD 8, LEAD 2)**

◀ Miniature

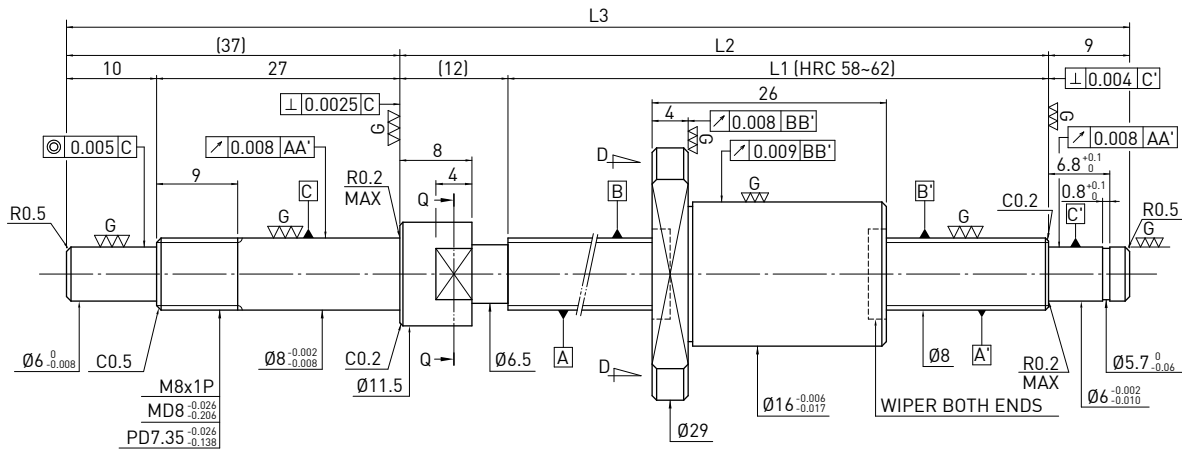

Ball screw Data	
Direction	Right Hand
Lead (mm)	2.0
Lead Angle	4.44°
P.C.D (mm)	8.2
Screw P.C.D (mm)	8.2
RD (mm)	6.652
Steel Ball (mm)	Ø1.5
Circuits	1x3
Dynamic Load C (Kgf)	170
Static Load Co (Kgf)	267
Axial Play (mm)	0      0.005 MAX
Drag Torque (Kgf-cm)	0.20 MAX      0.05 MAX
Spacer Ball	-      -

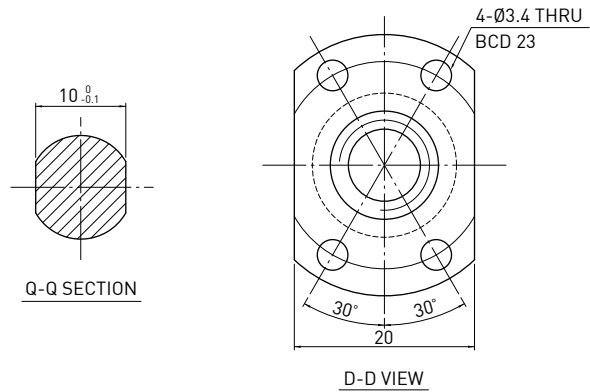

Unit : mm

Stroke	HIWIN Code	L1	L2	L3	Accuracy grade
40	R8-2T3-FSI-80-138-0.008	80	92	138	3
70	R8-2T3-FSI-110-168-0.008	110	122	168	3
100	R8-2T3-FSI-140-198-0.008	140	152	198	3
150	R8-2T3-FSI-190-248-0.008	190	202	248	3

**F S I TYPE (SHAFT OD 10, LEAD 2)**

◀ Miniature

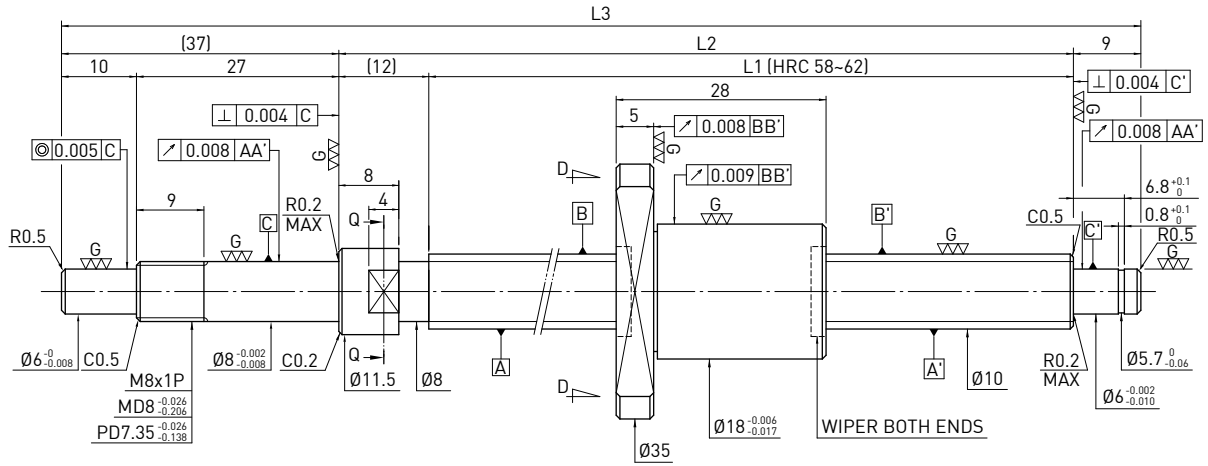

Ball screw Data		
Direction	Right Hand	
Lead (mm)	2	
Lead Angle	3.57°	
P.C.D (mm)	10.2	
Screw P.C.D (mm)	10.2	
RD (mm)	8.652	
Steel Ball (mm)	Ø1.5	
Circuits	1x3	
Dynamic Load C (Kgf)	196	
Static Load Co (Kgf)	348	
Axial Play (mm)	0	0.005 MAX
Drag Torque (Kgf-cm)	0.01-0.24	0.05 MAX
Spacer Ball	-	-

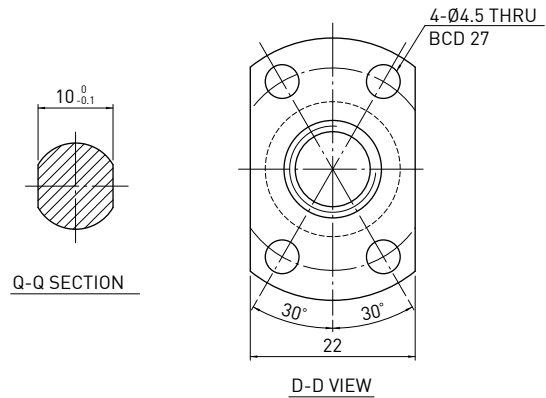

Unit : mm

Stroke	HIWIN Code	L1	L2	L3	Accuracy grade
50	R10-2T3-FSI-100-158-0.008	100	112	158	3
100	R10-2T3-FSI-150-208-0.008	150	162	208	3
150	R10-2T3-FSI-200-258-0.008	200	212	258	3
200	R10-2T3-FSI-250-308-0.008	250	262	308	3



**F S I TYPE (SHAFT OD 10, LEAD 2.5)**

◀ Miniature

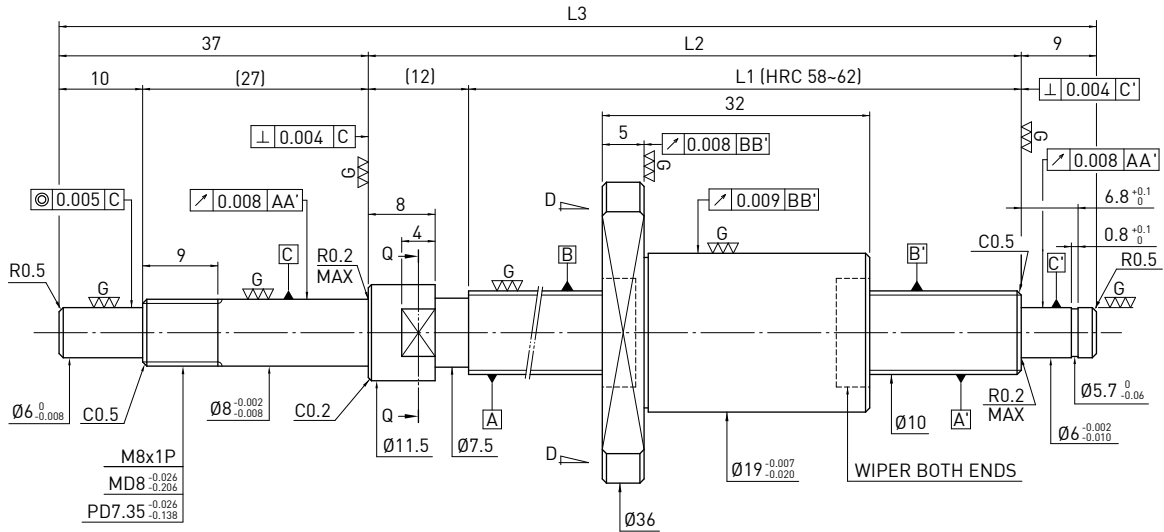

Ball screw Data	
Direction	Right Hand
Lead (mm)	2.5
Lead Angle	4.46°
P.C.D (mm)	10.2
Screw P.C.D (mm)	10.2
RD (mm)	8.136
Steel Ball (mm)	Ø2
Circuits	1x3
Dynamic Load C (Kgf)	274
Static Load Co (Kgf)	438
Axial Play (mm)	0      0.005 MAX
Drag Torque (Kgf-cm)	0.02-0.3      0.05 MAX
Spacer Ball	-      -

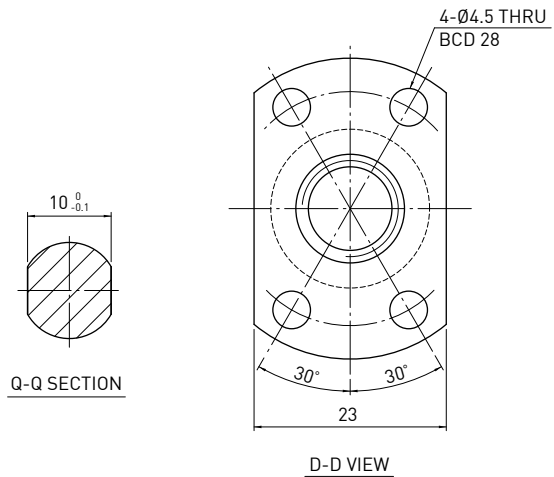

Unit : mm

Stroke	HIWIN Code	L1	L2	L3	Accuracy grade
50	R10-2.5T3-FSI-100-158-0.008	100	112	158	3
100	R10-2.5T3-FSI-150-208-0.008	150	162	208	3
150	R10-2.5T3-FSI-200-258-0.008	200	212	258	3
200	R10-2.5T3-FSI-250-308-0.008	250	262	308	3

**F S I** TYPE (SHAFT OD 12, LEAD 2)

◀ Miniature

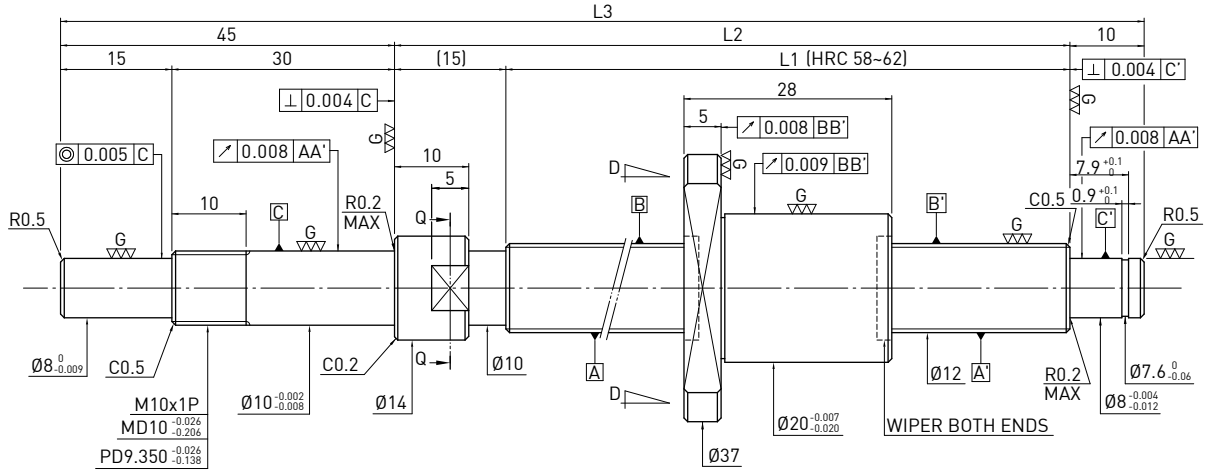

Ball screw Data	
Direction	Right Hand
Lead (mm)	2
Lead Angle	2.99°
P.C.D (mm)	12.2
Screw P.C.D (mm)	12.2
RD (mm)	10.625
Steel Ball (mm)	Ø1.5
Circuits	1x3
Dynamic Load C (Kgf)	217
Static Load Co (Kgf)	430
Axial Play (mm)	0      0.005 MAX
Drag Torque (Kgf-cm)	0.04-0.35      0.1 MAX
Spacer Ball	-      -

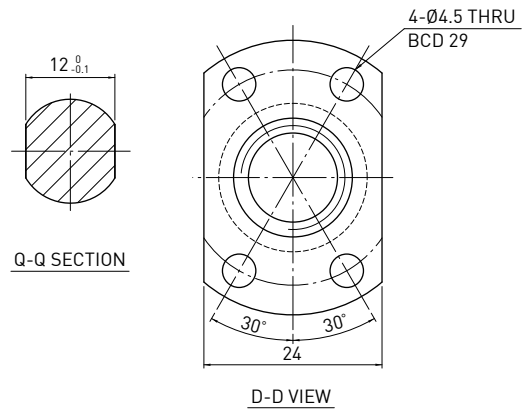

Unit : mm

Stroke	HIWIN Code	L1	L2	L3	Accuracy grade
50	R12-2T3-FSI-110-180-0.008	110	125	180	3
100	R12-2T3-FSI-160-230-0.008	160	175	230	3
150	R12-2T3-FSI-210-280-0.008	210	225	280	3
200	R12-2T3-FSI-260-330-0.008	260	275	330	3
250	R12-2T3-FSI-310-380-0.008	310	325	380	3

**F S I TYPE (SHAFT OD 12, LEAD 2.5)**

◀ Miniature

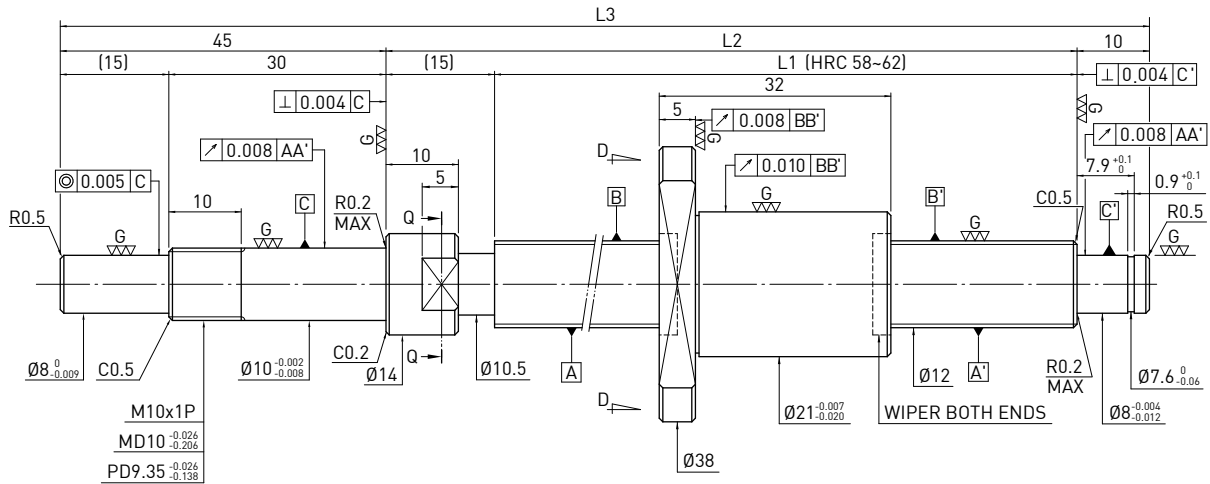

Ball screw Data	
Direction	Right Hand
Lead (mm)	2.5
Lead Angle	3.73°
P.C.D (mm)	12.2
Screw P.C.D (mm)	12.2
RD (mm)	10.136
Steel Ball (mm)	Ø2
Circuits	1x3
Dynamic Load C (Kgf)	309
Static Load Co (Kgf)	546
Axial Play (mm)	0      0.005 MAX
Drag Torque (Kgf-cm)	0.04-0.35      0.1 MAX
Spacer Ball	-      -

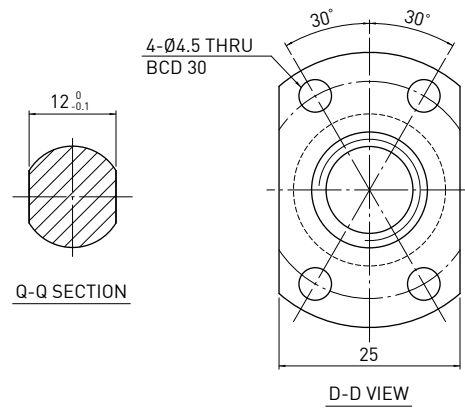

Unit : mm

Stroke	HIWIN Code	L1	L2	L3	Accuracy grade
50	R12-2.5T3-FSI-110-180-0.008	110	125	180	3
100	R12-2.5T3-FSI-160-230-0.008	160	175	230	3
150	R12-2.5T3-FSI-210-280-0.008	210	225	280	3
200	R12-2.5T3-FSI-260-330-0.008	260	275	330	3
250	R12-2.5T3-FSI-310-380-0.008	310	325	380	3

**F S I TYPE (SHAFT OD 14, LEAD 2)**

◀ Miniature

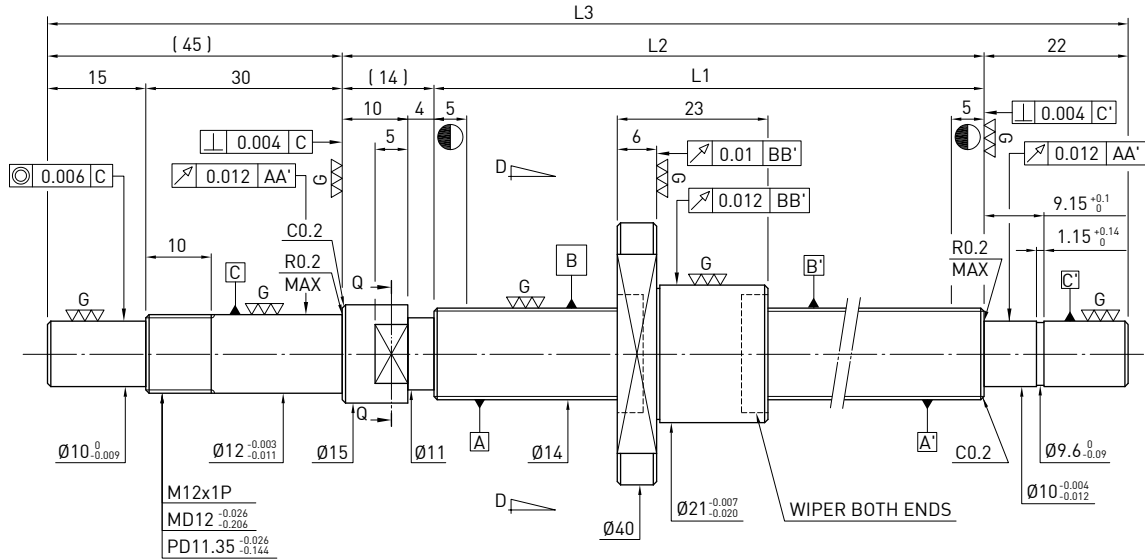

Ball screw Data	
Direction	Right Hand
Lead (mm)	2
Lead Angle	2.57°
P.C.D (mm)	14.2
Screw P.C.D (mm)	14.2
RD (mm)	12.652
Steel Ball (mm)	$\varnothing 1.5$
Circuits	1x3
Dynamic Load C (Kgf)	236
Static Load Co (Kgf)	511
Axial Play (mm)	0      0.005 or less
Drag Torque (Kgf-cm)	0.05-0.5      -
Spacer Ball	-      -

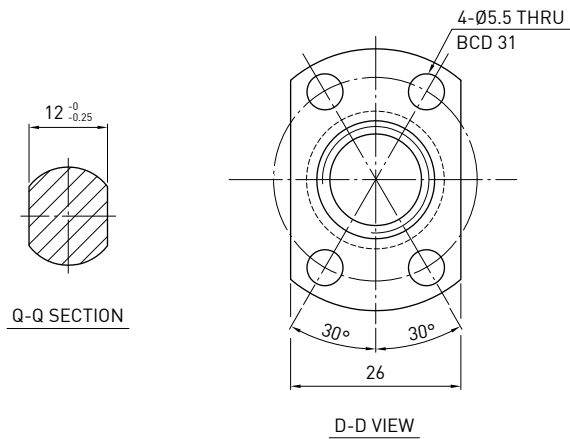

Unit : mm

Stroke	HIWIN Code	L1	L2	L3	Accuracy grade
50	R14-2T3-FSI-85-166-0.008	85	99	166	3
100	R14-2T3-FSI-135-216-0.008	135	149	216	3
150	R14-2T3-FSI-185-266-0.008	185	199	266	3
200	R14-2T3-FSI-235-316-0.008	235	249	316	3
250	R14-2T3-FSI-335-416-0.008	335	349	416	3

**F S I TYPE (SHAFT OD 14, LEAD 4)**

◀ Miniature

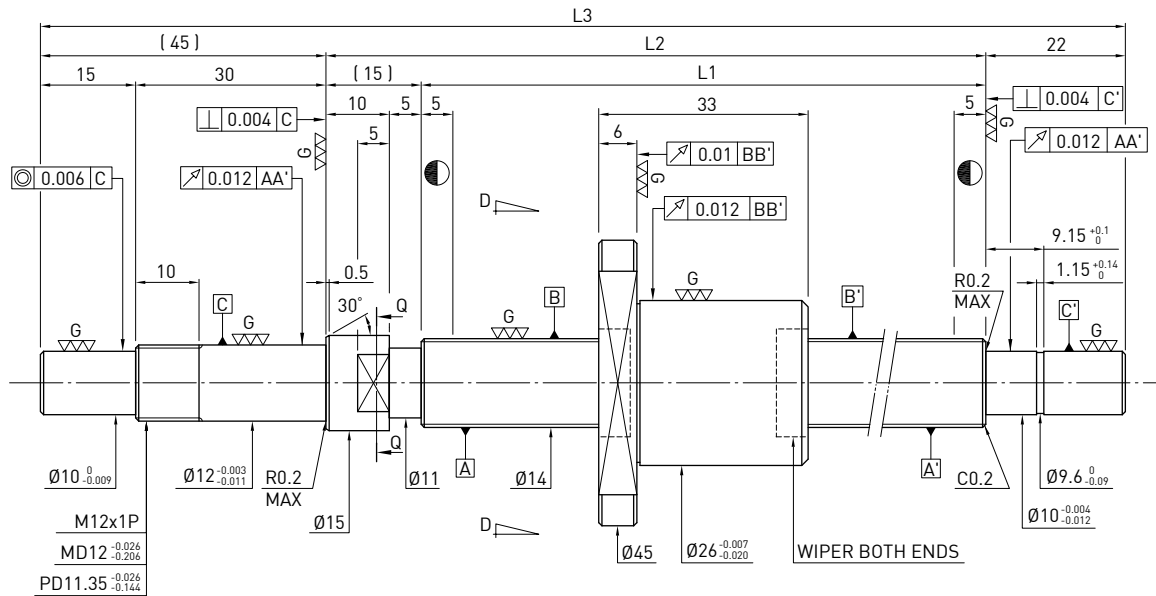

Ball screw Data	
Direction	Right Hand
Lead (mm)	4
Lead Angle	5.11°
P.C.D (mm)	14.25
Screw P.C.D (mm)	14.25
RD (mm)	11.792
Steel Ball (mm)	Ø2.381
Circuits	1x3
Dynamic Load C (Kgf)	403
Static Load Co (Kgf)	725
Axial Play (mm)	0      0.005 or less
Drag Torque (Kgf-cm)	0.1-0.7      -
Spacer Ball	-      -

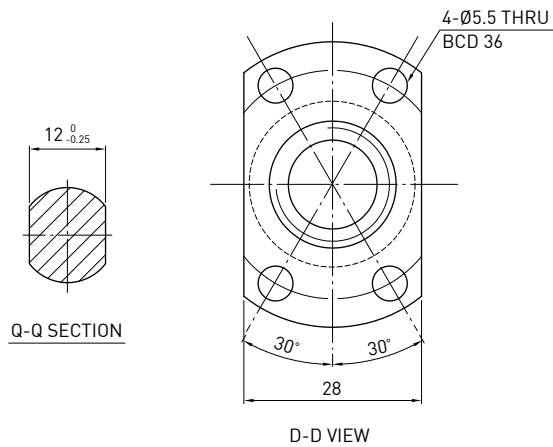

Unit : mm

Stroke	HIWIN Code	L1	L2	L3	Accuracy grade
100	R14-4T3-FSI-148-230-0.008	148	163	230	3
150	R14-4T3-FSI-198-280-0.008	198	213	280	3
200	R14-4T3-FSI-248-330-0.008	248	263	330	3
300	R14-4T3-FSI-348-430-0.008	348	363	430	3
400	R14-4T3-FSI-448-530-0.008	448	463	530	3

**F S B TYPE (SHAFT OD 10, LEAD 4)**

◀ Miniature

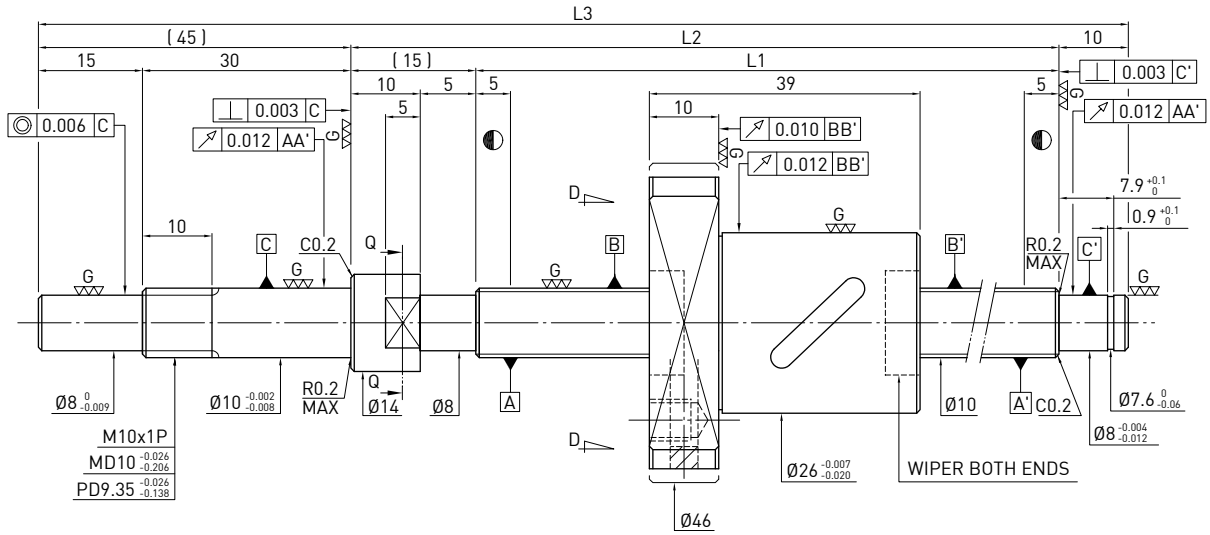

Ball screw Data	
Direction	Right Hand
Lead (mm)	4
Lead Angle	7.11°
P.C.D (mm)	10.2
Screw P.C.D (mm)	10.2
RD (mm)	8.136
Steel Ball (mm)	Ø2
Circuits	2.5x1
Dynamic Load C (Kgf)	176      280
Static Load Co (Kgf)	225      449
Axial Play (mm)	0      0.005 or less
Drag Torque (Kgf-cm)	0.05-0.4      -0.1
Spacer Ball	1 : 1      -

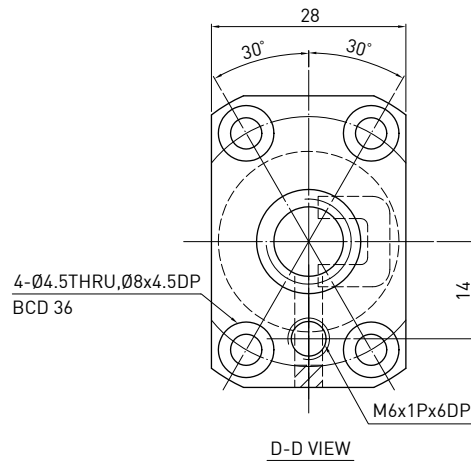
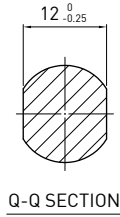

Unit : mm

Stroke	HIWIN Code	L1	L2	L3	Accuracy grade
50	R10-4B1-FSB-110-180-0.008	110	125	180	3
100	R10-4B1-FSB-160-230-0.008	160	175	230	3
150	R10-4B1-FSB-210-280-0.008	210	225	280	3
200	R10-4B1-FSB-260-330-0.008	260	275	330	3
250	R10-4B1-FSB-310-380-0.008	310	325	380	3
300	R10-4B1-FSB-360-430-0.008	360	375	430	3

**F S W TYPE (SHAFT OD 12, LEAD 5)**

◀ Miniature

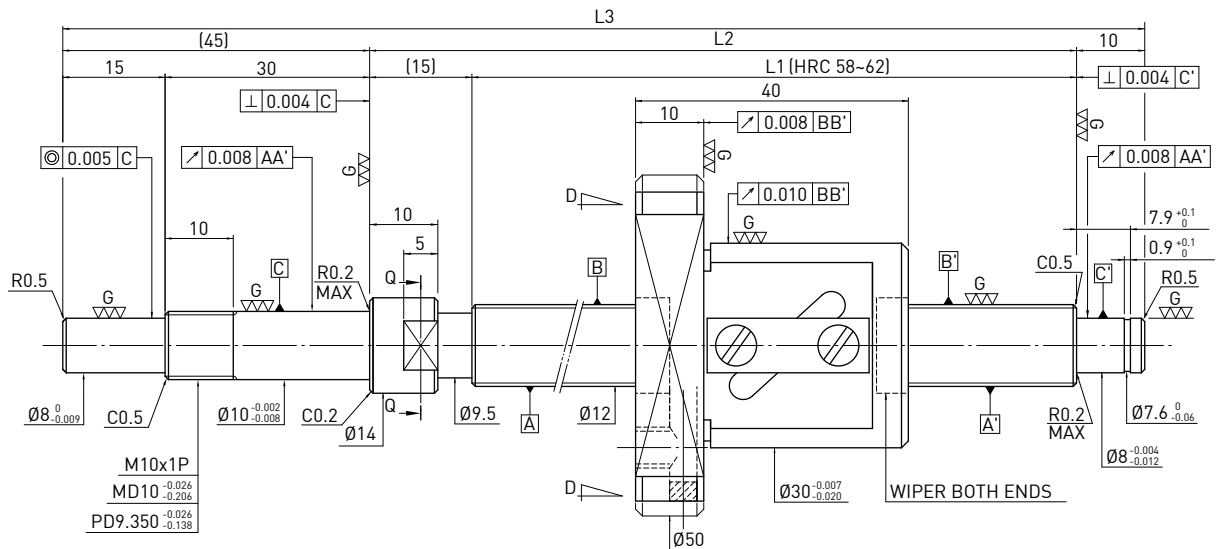

Ball screw Data	
Direction	Right Hand
Lead (mm)	5
Lead Angle	7.4°
P.C.D (mm)	12.25
Screw P.C.D (mm)	12.25
RD (mm)	9.792
Steel Ball (mm)	Ø2.381
Circuits	2.5x1
Dynamic Load C (Kgf)	241      382
Static Load Co (Kgf)	319      637
Axial Play (mm)	0      0.005 MAX
Drag Torque (Kgf-cm)	0.1-0.45      0.1 MAX
Spacer Ball	1 : 1      -

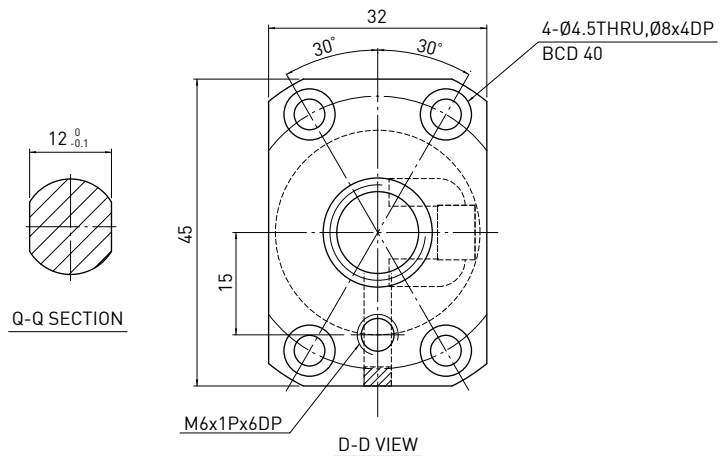

Unit : mm

Stroke	HIWIN Code	L1	L2	L3	Accuracy grade
50	R12-5B1-FSW -110-180-0.008	110	125	180	3
100	R12-5B1-FSW -160-230-0.008	160	175	230	3
150	R12-5B1-FSW -210-280-0.008	210	225	280	3
200	R12-5B1-FSW -260-330-0.008	260	275	330	3
250	R12-5B1-FSW -310-380-0.008	310	325	380	3
350	R12-5B1-FSW -410-480-0.008	410	425	480	3
450	R12-5B1-FSW -510-580-0.008	510	525	580	3

**F S W TYPE (SHAFT OD 12, LEAD 10)**

◀ Miniature

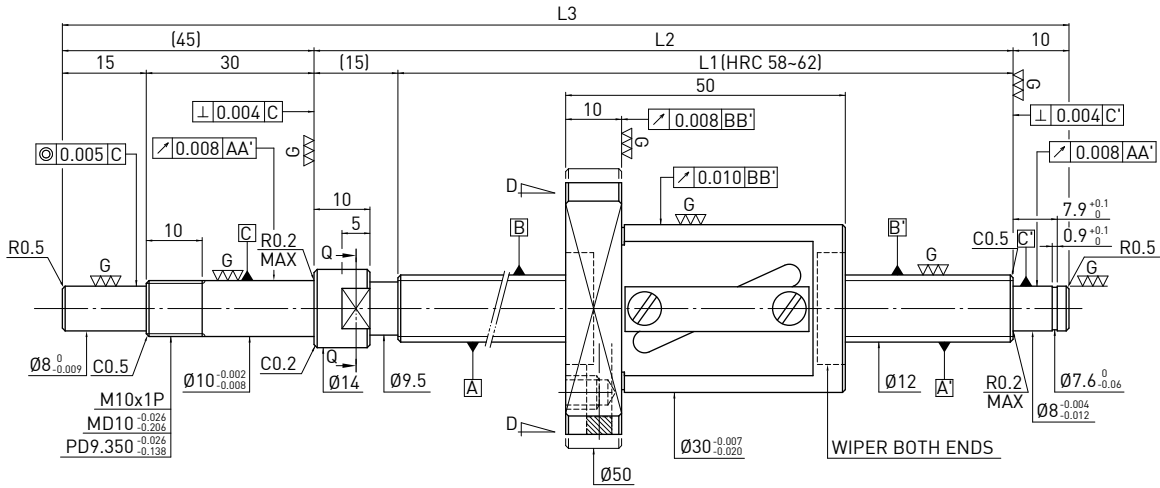

Ball screw Data		
Direction	Right Hand	
Lead (mm)	10	
Lead Angle	14.57°	
P.C.D (mm)	12.25	
Screw P.C.D (mm)	12.25	
RD (mm)	9.792	
Steel Ball (mm)	Ø2.381	
Circuits	2.5x1	
Dynamic Load C (Kgf)	241	382
Static Load Co (Kgf)	319	637
Axial Play (mm)	0	0.005 MAX
Drag Torque (Kgf-cm)	0.1-0.5	0.5 MAX
Spacer Ball	1 : 1	-

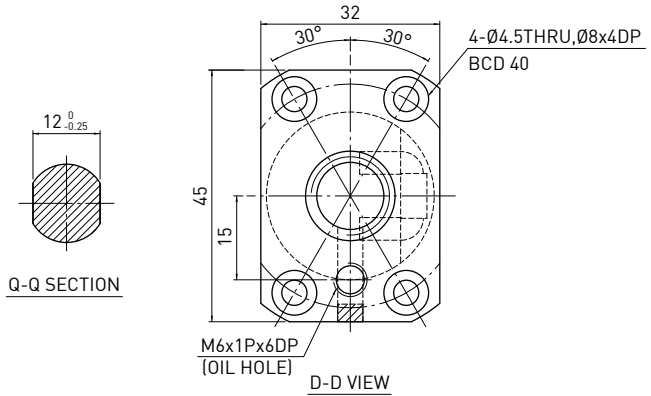

Unit : mm

Stroke	HIWIN Code	L1	L2	L3	Accuracy grade
100	R12-10B1-FSW-160-230-0.008	160	175	230	3
150	R12-10B1-FSW-210-280-0.008	210	225	280	3
250	R12-10B1-FSW-310-380-0.008	310	325	380	3
350	R12-10B1-FSW-410-480-0.008	410	425	480	3
450	R12-10B1-FSW-510-580-0.008	510	525	580	3



**F S W TYPE (SHAFT OD 14, LEAD 5)**

◀ Miniature

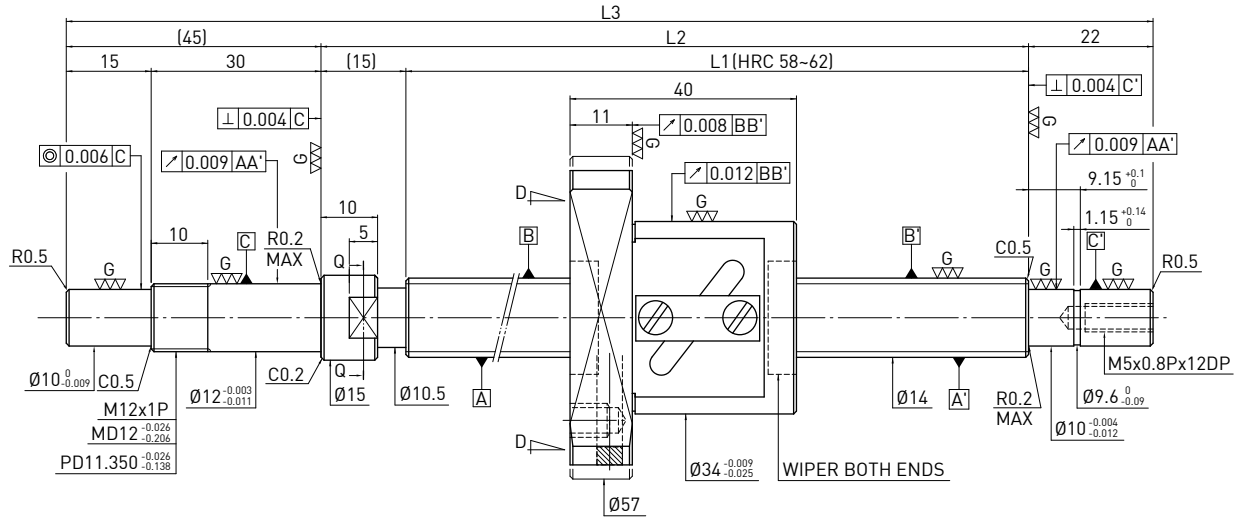

Ball screw Data	
Direction	Right Hand
Lead (mm)	5
Lead Angle	6.22°
P.C.D (mm)	14.6
Screw P.C.D (mm)	14.6
RD (mm)	11.324
Steel Ball (mm)	Ø3.175
Circuits	2.5x1
Dynamic Load C (Kgf)	448      710
Static Load Co (Kgf)	608      1215
Axial Play (mm)	0      0.005 MAX
Drag Torque (Kgf-cm)	0.15-0.70      0.2 MAX
Spacer Ball	1 : 1      -

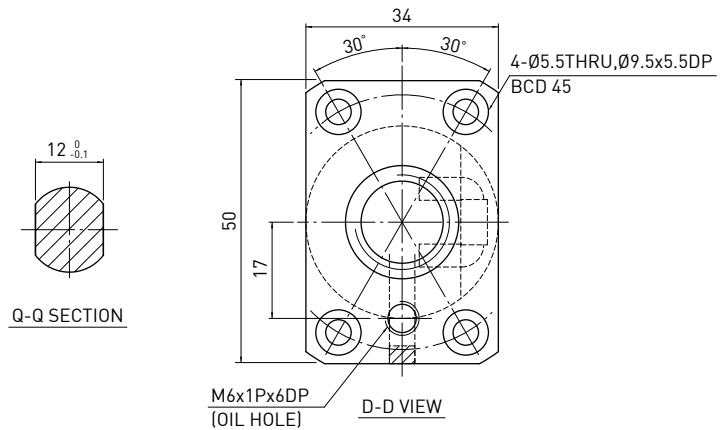

Unit : mm

Stroke	HIWIN Code	L1	L2	L3	Accuracy grade
100	R14-5B1-FSW-189-271-0.008	189	204	271	3
150	R14-5B1-FSW-239-321-0.008	239	254	321	3
250	R14-5B1-FSW-339-421-0.008	339	354	421	3
350	R14-5B1-FSW-439-521-0.008	439	454	521	3
450	R14-5B1-FSW-539-621-0.008	539	554	621	3
600	R14-5B1-FSW-689-771-0.008	689	704	771	3

**F S W TYPE (SHAFT OD 14, LEAD 8)**

◀ Miniature

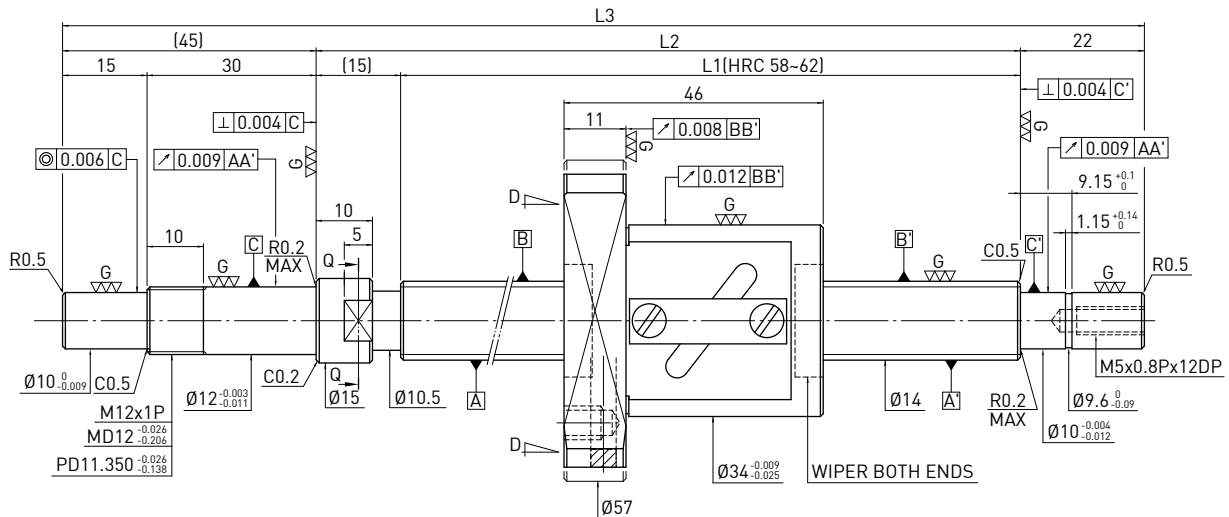

Ball screw Data	
Direction	Right Hand
Lead (mm)	8
Lead Angle	9.89°
P.C.D (mm)	14.6
Screw P.C.D (mm)	14.6
RD (mm)	11.324
Steel Ball (mm)	Ø3.175
Circuits	2.5x1
Dynamic Load C (Kgf)	448      710
Static Load Co (Kgf)	608      1215
Axial Play (mm)	0      0.005 MAX
Drag Torque (Kgf-cm)	0.15-0.79      0.24 MAX
Spacer Ball	1 : 1      -

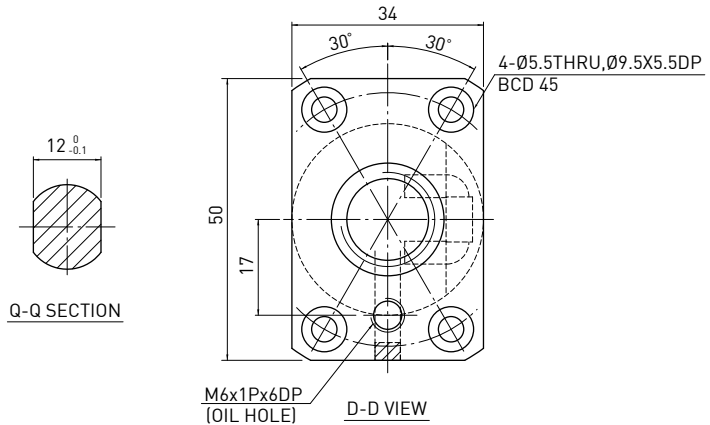

Unit : mm

Stroke	HIWIN Code	L1	L2	L3	Accuracy grade
100	R14-8B1-FSW-189-271-0.008	189	204	271	3
150	R14-8B1-FSW-239-321-0.008	239	254	321	3
200	R14-8B1-FSW-289-371-0.008	289	304	371	3
250	R14-8B1-FSW-339-421-0.008	339	354	421	3
300	R14-8B1-FSW-389-471-0.008	389	404	471	3
350	R14-8B1-FSW-439-521-0.008	439	454	521	3
400	R14-8B1-FSW-489-571-0.008	489	504	571	3
450	R14-8B1-FSW-539-621-0.008	539	554	621	3
500	R14-8B1-FSW-589-671-0.008	589	604	671	3
550	R14-8B1-FSW-639-721-0.008	639	654	721	3
600	R14-8B1-FSW-689-771-0.008	689	704	771	3
700	R14-8B1-FSW-789-871-0.008	789	804	871	3

**F S B TYPE (SHAFT OD 10, LEAD 10)**

◀ Miniature

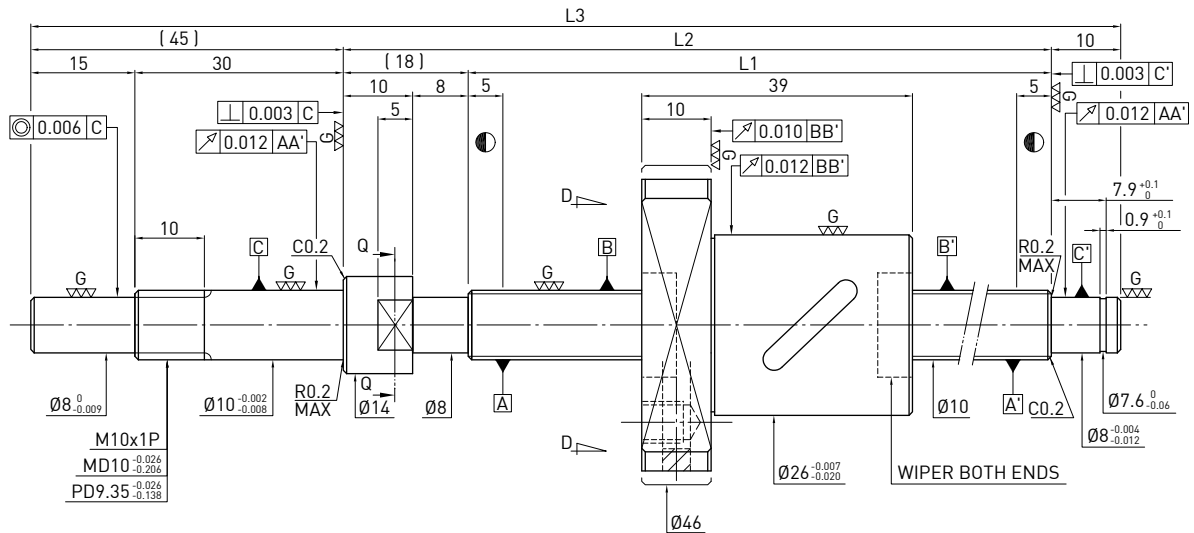

Ball screw Data	
Direction	Right Hand
Lead (mm)	10
Lead Angle	16.71°
P.C.D (mm)	10.6
Screw P.C.D (mm)	10.6
RD (mm)	7.324
Steel Ball (mm)	Ø3.175
Circuits	1.5x1
Dynamic Load C (Kgf)	223      354
Static Load Co (Kgf)	245      489
Axial Play (mm)	0      0.005 or less
Drag Torque (Kgf-cm)	0.1-0.5      -
Spacer Ball	1 : 1      -

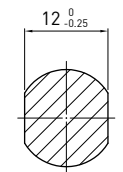

Q-Q SECTION

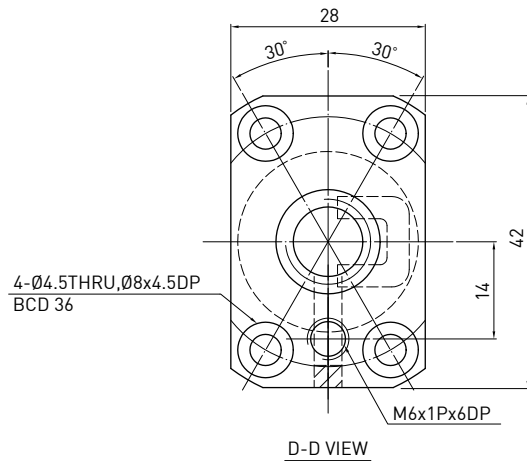

D-D VIEW

Unit : mm

Stroke	HIWIN Code	L1	L2	L3	Accuracy grade
100	R10-10A1-FSB-167-240-0.008	167	185	240	3
150	R10-10A1-FSB-217-290-0.008	217	235	290	3
200	R10-10A1-FSB-267-340-0.008	267	285	340	3
250	R10-10A1-FSB-317-390-0.008	317	335	390	3
300	R10-10A1-FSB-367-440-0.008	367	385	440	3

## 6.4 End Machining Ground Ballscrew Series

**F S W TYPE (SHAFT OD 15, LEAD 10)**

◀ Standard

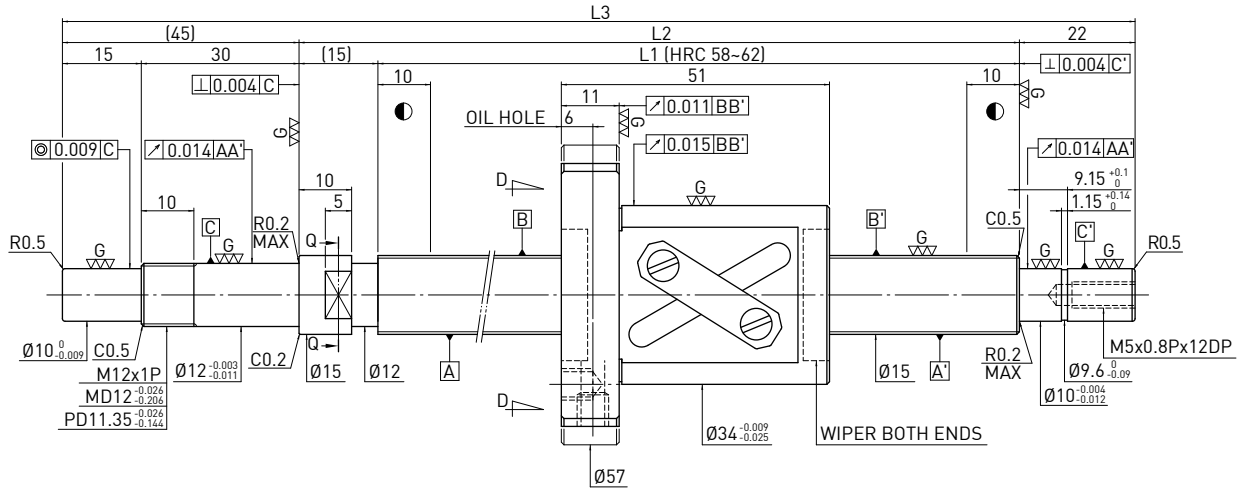

Ball screw Data	
Direction	Right Hand
Lead (mm)	10
Lead Angle	11.53°
P.C.D (mm)	15.6
Screw P.C.D (mm)	15.6
RD (mm)	12.324
Steel Ball (mm)	Ø3.175
Circuits	2.5x1
Dynamic Load C (Kgf)	460      729
Static Load Co (Kgf)	645      1290
Axial Play (mm)	0      0.005 MAX
Drag Torque (Kgf-cm)	0.15-0.79      0.24 MAX
Spacer Ball	1 : 1      -

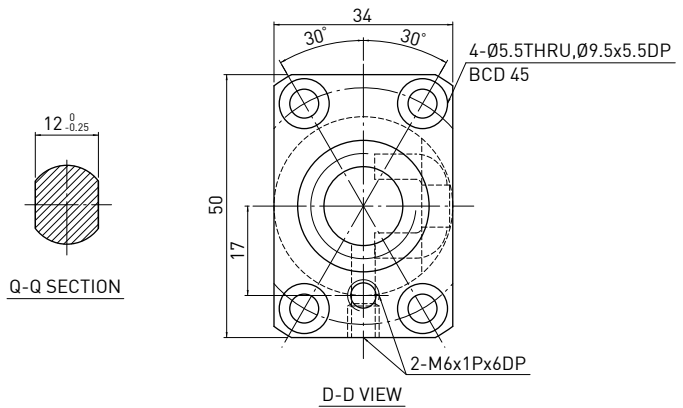

Unit : mm

Stroke	HIWIN Code	L1	L2	L3	Accuracy grade
100	R15-10B1-FSW-189-271-0.018	189	204	271	5
150	R15-10B1-FSW-239-321-0.018	239	254	321	5
200	R15-10B1-FSW-289-371-0.018	289	304	371	5
250	R15-10B1-FSW-339-421-0.018	339	354	421	5
300	R15-10B1-FSW-389-471-0.018	389	404	471	5
350	R15-10B1-FSW-439-521-0.018	439	454	521	5
400	R15-10B1-FSW-489-571-0.018	489	504	571	5
450	R15-10B1-FSW-539-621-0.018	539	554	621	5
500	R15-10B1-FSW-589-671-0.018	589	604	671	5
550	R15-10B1-FSW-639-721-0.018	639	654	721	5
600	R15-10B1-FSW-689-771-0.018	689	704	771	5
700	R15-10B1-FSW-789-871-0.018	789	804	871	5
800	R15-10B1-FSW-889-971-0.018	889	904	971	5
1000	R15-10B1-FSW-1089-1171-0.018	1089	1104	1171	5

**F S W TYPE (SHAFT OD 16, LEAD 5)**

◀ Standard

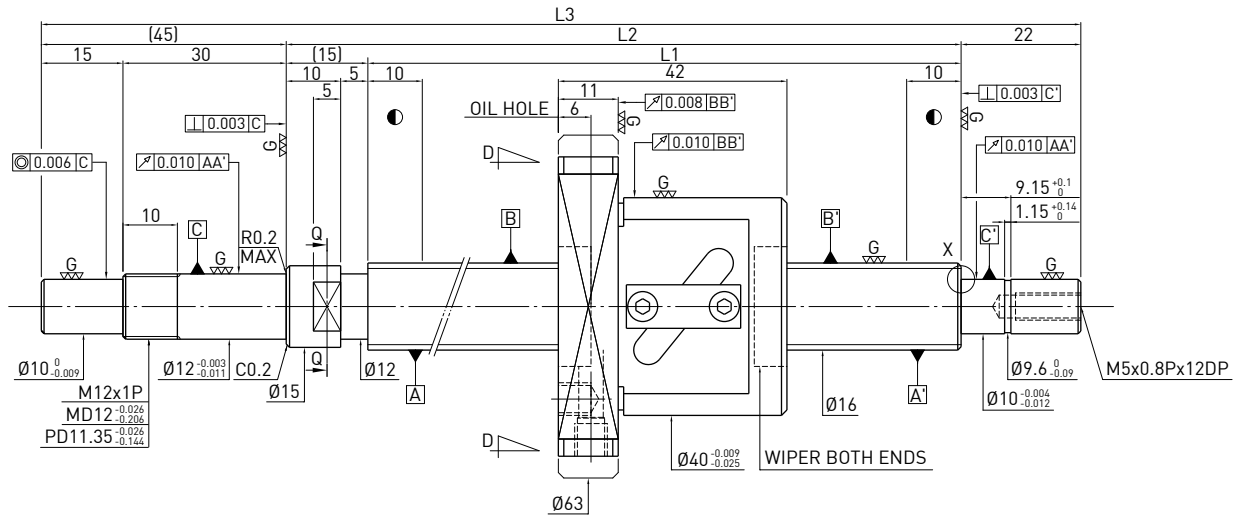

Ball screw Data	
Direction	Right Hand
Lead (mm)	5
Lead Angle	5.48°
P.C.D (mm)	16.6
Screw P.C.D (mm)	16.2
RD (mm)	13.324
Steel Ball (mm)	Ø3.175
Circuits	2.5x1
Dynamic Load C (Kgf)	481      763
Static Load Co (Kgf)	670      1399
Axial Play (mm)	0      0.005 or less
Drag Torque (Kgf-cm)	0.15~0.8      ~0.2
Spacer Ball	1 : 1      -

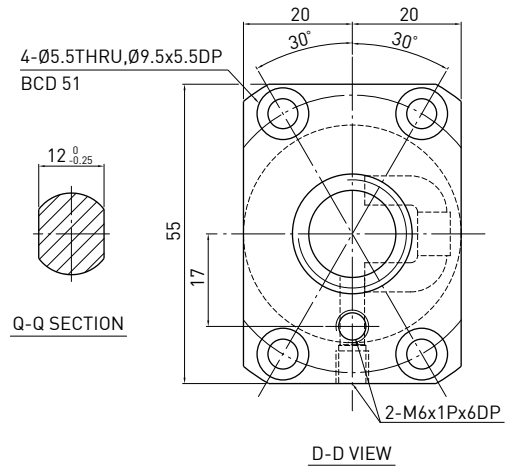
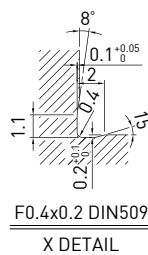

Unit : mm

Stroke	HIWIN Code	L1	L2	L3	Accuracy grade
100	R16-5B1-FSW-189-271-0.018	189	204	271	5
200	R16-5B1-FSW-289-371-0.018	289	304	371	5
300	R16-5B1-FSW-389-471-0.018	389	404	471	5
400	R16-5B1-FSW-489-571-0.018	489	504	571	5
600	R16-5B1-FSW-689-771-0.018	689	704	771	5
800	R16-5B1-FSW-889-971-0.018	889	904	971	5

**F S W TYPE (SHAFT OD 20, LEAD 4)**

◀ Standard

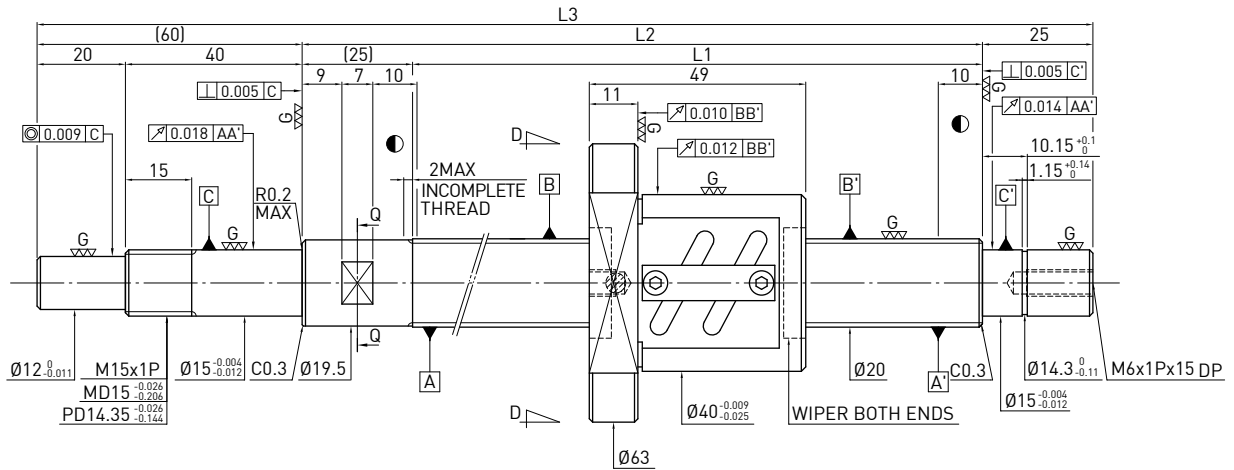

Ball screw Data	
Direction	Right Hand
Lead (mm)	4
Lead Angle	3.6°
P.C.D (mm)	20.25
Screw P.C.D (mm)	20.25
RD (mm)	17.792
Steel Ball (mm)	Ø2.381
Circuits	2.5x2
Dynamic Load C (Kgf)	561
Static Load Co (Kgf)	1085
Axial Play (mm)	0
Drag Torque (Kgf-cm)	0.12-0.68
Spacer Ball	1 : 1

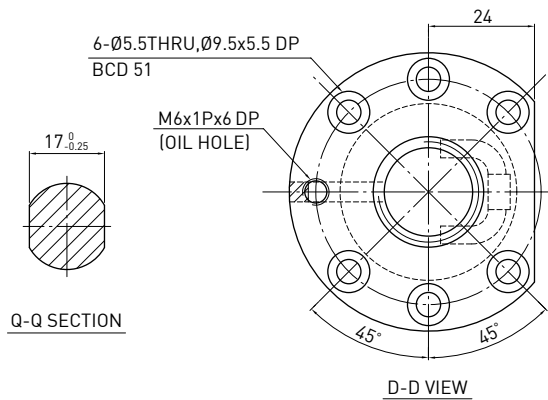

Unit : mm

Stroke	HIWIN Code	L1	L2	L3	Accuracy grade
150	R20-4B2-FSW-225-335-0.018	225	250	335	5
200	R20-4B2-FSW-275-385-0.018	275	300	385	5
300	R20-4B2-FSW-375-485-0.018	375	400	485	5
400	R20-4B2-FSW-475-585-0.018	475	500	585	5
500	R20-4B2-FSW-575-685-0.018	575	600	685	5
350	R15-10B1-FSW-439-521-0.018	439	454	521	5

**F S W TYPE (SHAFT OD 20, LEAD 5)**

◀ Standard

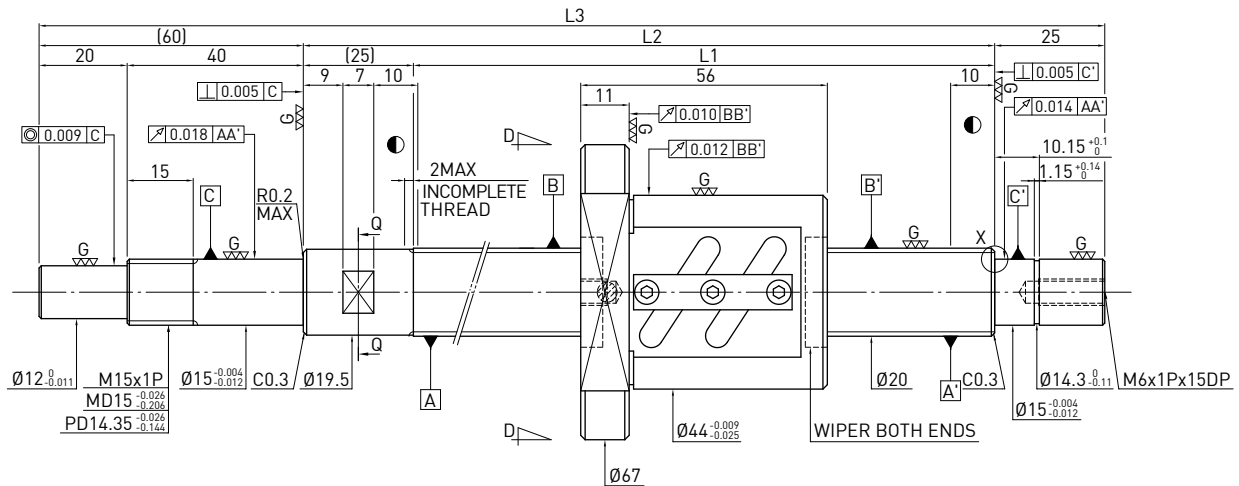

Ballscrew Data	
Direction	Right Hand
Lead (mm)	5
Lead Angle	4.42°
P.C.D (mm)	20.6
Screw P.C.D (mm)	20.6
RD (mm)	17.324
Steel Ball (mm)	Ø3.175
Circuits	2.5x2
Dynamic Load C (Kgf)	952
Static Load Co (Kgf)	1732
Axial Play (mm)	0
Drag Torque (Kgf-cm)	0.28-1.32
Spacer Ball	1 : 1

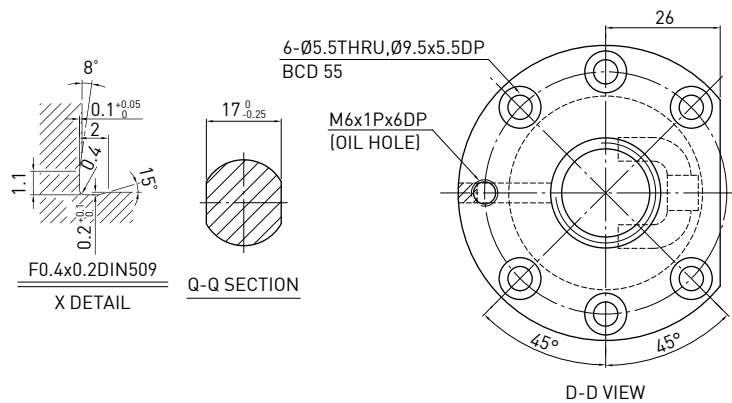

Unit : mm

Stroke	HIWIN Code	L1	L2	L3	Accuracy grade
150	R20-5B2-FSW-225-335-0.018	225	250	335	5
200	R20-5B2-FSW-275-385-0.018	275	300	385	5
300	R20-5B2-FSW-375-485-0.018	375	400	485	5
400	R20-5B2-FSW-475-585-0.018	475	500	585	5
500	R20-5B2-FSW-575-685-0.018	575	600	685	5
700	R20-5B2-FSW-775-885-0.018	775	800	885	5

**F S W** TYPE (SHAFT OD 20, LEAD 10)

◀ Standard

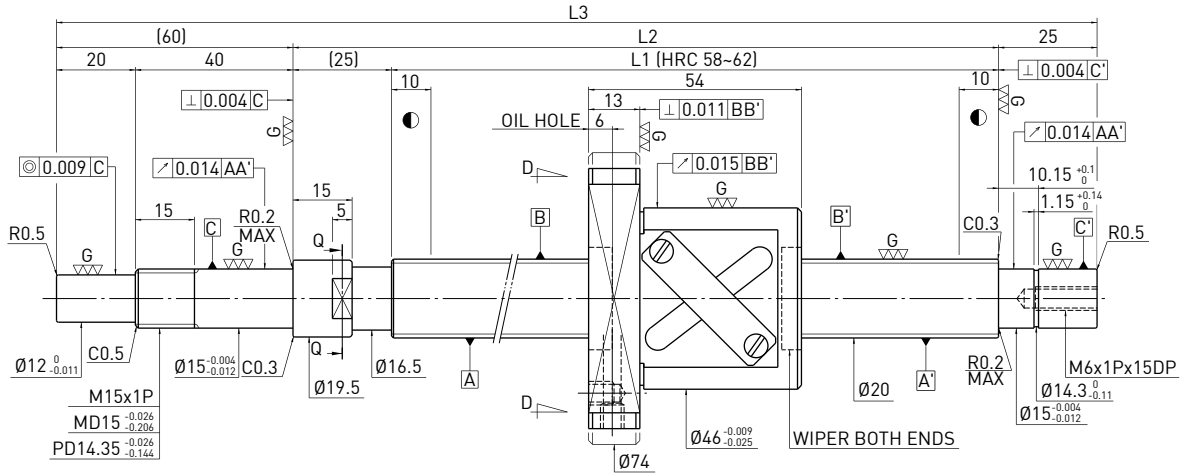

Ball screw Data	
Direction	Right Hand
Lead (mm)	10
Lead Angle	8.7°
P.C.D (mm)	20.8
Screw P.C.D (mm)	20.8
RD (mm)	16.744
Steel Ball (mm)	Ø3.969
Circuits	2.5x1
Dynamic Load C (Kgf)	718      1139
Static Load Co (Kgf)	1094      2187
Axial Play (mm)	0      0.005 MAX
Drag Torque (Kgf-cm)	0.2-1.2      0.3 MAX
Spacer Ball	1 : 1      -

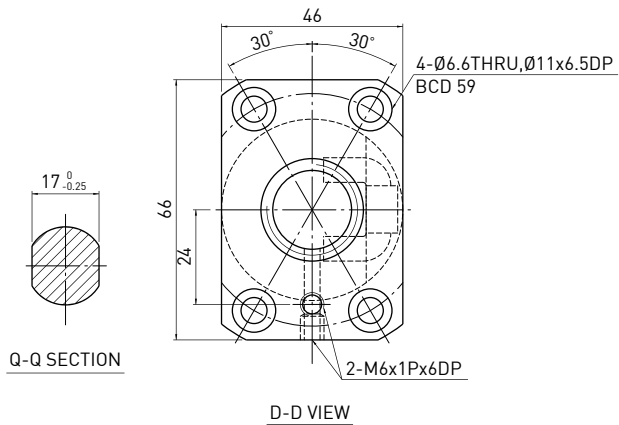

Unit : mm

Stroke	HIWIN Code	L1	L2	L3	Accuracy grade
200	R20-10B1-FSW- 289 - 399-0.018	289	314	399	5
300	R20-10B1-FSW- 389 - 499-0.018	389	414	499	5
400	R20-10B1-FSW- 489 - 599-0.018	489	514	599	5
500	R20-10B1-FSW- 589 - 699-0.018	589	614	699	5
600	R20-10B1-FSW- 689 - 799-0.018	689	714	799	5
700	R20-10B1-FSW- 789 - 899-0.018	789	814	899	5
800	R20-10B1-FSW- 889 - 999-0.018	889	914	999	5
900	R20-10B1-FSW- 989 - 1099-0.018	989	1014	1099	5
1000	R20-10B1-FSW- 1089 - 1199-0.018	1089	1114	1199	5
1100	R20-10B1-FSW- 1189 - 1299-0.018	1189	1214	1299	5
1400	R20-10B1-FSW- 1289 - 1399-0.018	1289	1314	1399	5



**F S W** TYPE (SHAFT OD 20, LEAD 20)

◀ Standard

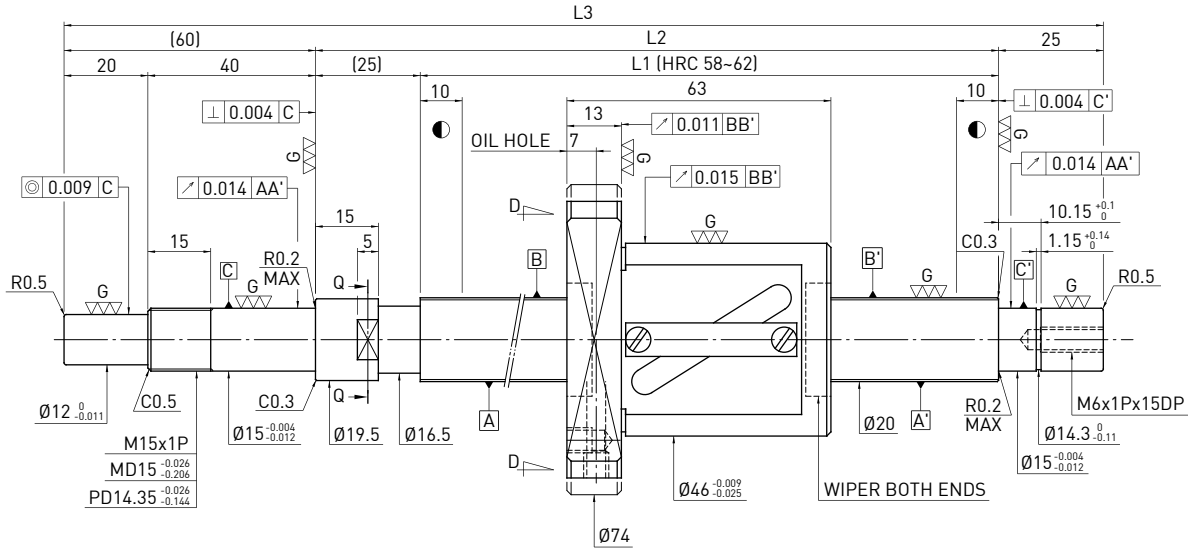

Ball screw Data	
Direction	Right Hand
Lead (mm)	20
Lead Angle	17.01°
P.C.D (mm)	20.8
Screw P.C.D (mm)	20.8
RD (mm)	16.744
Steel Ball (mm)	Ø3.969
Circuits	1.5x1
Dynamic Load C (Kgf)	453      719
Static Load Co (Kgf)	641      1280
Axial Play (mm)	0      0.005 MAX
Drag Torque (Kgf-cm)	0.2-1.2      0.3 MAX
Spacer Ball	1 : 1      -

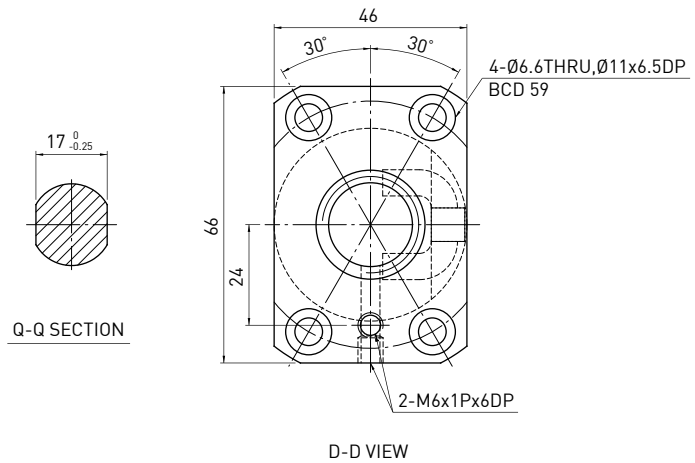

Unit : mm

Stroke	HIWIN Code	L1	L2	L3	Accuracy grade
200	R20-20A1-FSW-310-420-0.018	310	335	420	5
300	R20-20A1-FSW-410-520-0.018	410	435	520	5
400	R20-20A1-FSW-510-620-0.018	510	535	620	5
500	R20-20A1-FSW-610-720-0.018	610	635	720	5
600	R20-20A1-FSW-710-820-0.018	710	735	820	5
700	R20-20A1-FSW-810-920-0.018	810	835	920	5
800	R20-20A1-FSW-910-1020-0.018	910	935	1020	5
900	R20-20A1-FSW-1010-1120-0.018	1010	1035	1120	5
1000	R20-20A1-FSW-1110-1220-0.018	1110	1135	1220	5
1100	R20-20A1-FSW-1210-1320-0.018	1210	1235	1320	5
1400	R20-20A1-FSW-1510-1620-0.018	1510	1535	1620	5

**F S W** TYPE (SHAFT OD 25, LEAD 4)

◀ Standard

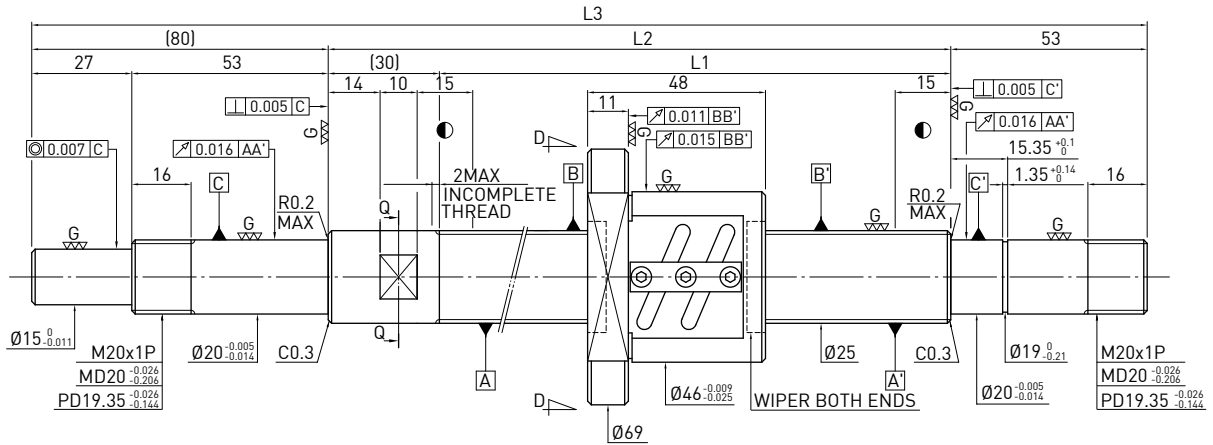

Ball screw Data	
Direction	Right Hand
Lead (mm)	4
Lead Angle	2.89°
P.C.D (mm)	25.25
Screw P.C.D (mm)	25.25
RD (mm)	22.792
Steel Ball (mm)	$\varnothing 3.81$
Circuits	2.5x2
Dynamic Load C (Kgf)	622
Static Load Co (Kgf)	1376
Axial Play (mm)	0
Drag Torque (Kgf-cm)	0.15-0.85
Spacer Ball	1 : 1

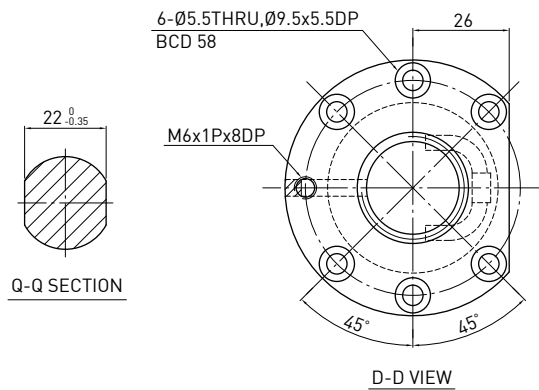

Unit : mm

Stroke	HIWIN Code	L1	L2	L3	Accuracy grade
150	R25-4B2-FSW-220-383-0.018	220	250	383	5
200	R25-4B2-FSW-270-433-0.018	270	300	433	5
300	R25-4B2-FSW-370-533-0.018	370	400	533	5
400	R25-4B2-FSW-470-633-0.018	470	500	633	5
500	R25-4B2-FSW-570-733-0.018	570	600	733	5

**F S W TYPE (SHAFT OD 25, LEAD 5)**

◀ Standard

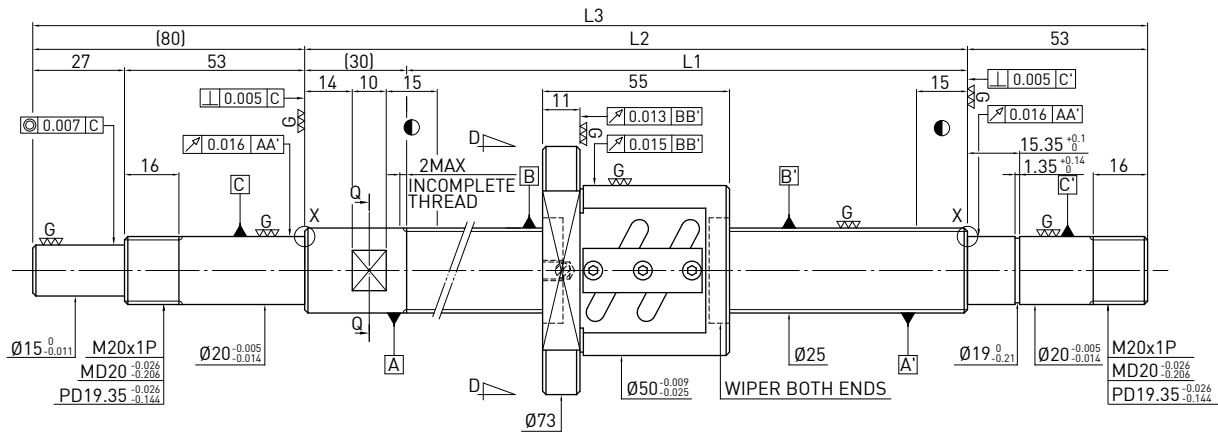

Ball screw Data	
Direction	Right Hand
Lead (mm)	5
Lead Angle	3.56°
P.C.D (mm)	25.6
Screw P.C.D (mm)	25.6
RD (mm)	22.324
Steel Ball (mm)	Ø3.175
Circuits	2.5x2
Dynamic Load C (Kgf)	1073
Static Load Co (Kgf)	2209
Axial Play (mm)	0
Drag Torque (Kgf-cm)	0.36~1.44
Spacer Ball	1 : 1

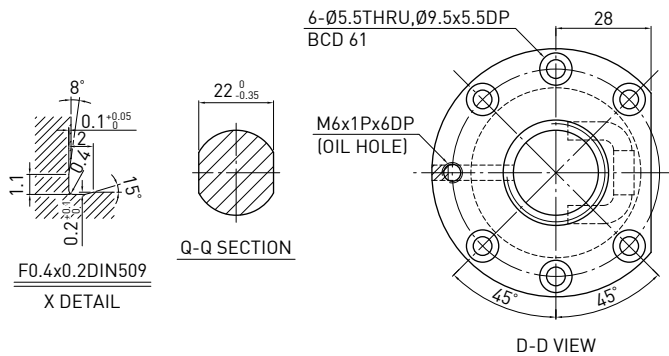

Unit : mm

Stroke	HIWIN Code	L1	L2	L3	Accuracy grade
150	R25-5B2-FSW-220-383-0.018	220	250	383	5
200	R25-5B2-FSW-270-433-0.018	270	300	433	5
300	R25-5B2-FSW-370-533-0.018	370	400	533	5
400	R25-5B2-FSW-470-633-0.018	470	500	633	5
500	R25-5B2-FSW-570-733-0.018	570	600	733	5
600	R25-5B2-FSW-670-833-0.018	670	700	833	5
700	R25-5B2-FSW-770-933-0.018	770	800	933	5
900	R25-5B2-FSW-970-1133-0.018	970	1000	1133	5
1000	R25-5B2-FSW-1170-1333-0.018	1170	1200	1333	5

**F S W TYPE (SHAFT OD 25, LEAD 6)**

◀ Standard

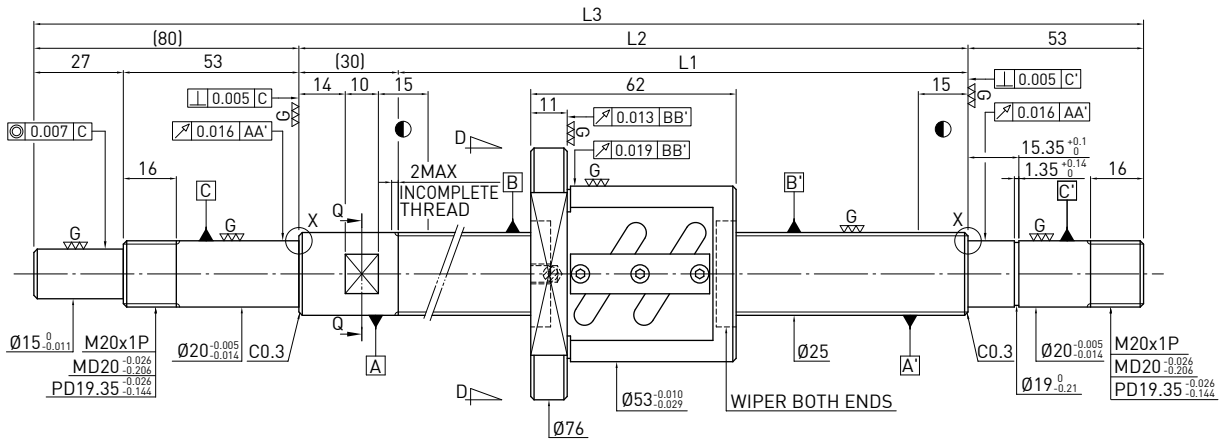

Ballscrew Data	
Direction	Right Hand
Lead (mm)	6
Lead Angle	4.23°
P.C.D (mm)	25.8
Screw P.C.D (mm)	25.8
RD (mm)	21.744
Steel Ball (mm)	Ø3.969
Circuits	2.5x2
Dynamic Load C (Kgf)	1453
Static Load Co (Kgf)	2761
Axial Play (mm)	0
Drag Torque (Kgf-cm)	0.42~2.4
Spacer Ball	1 : 1

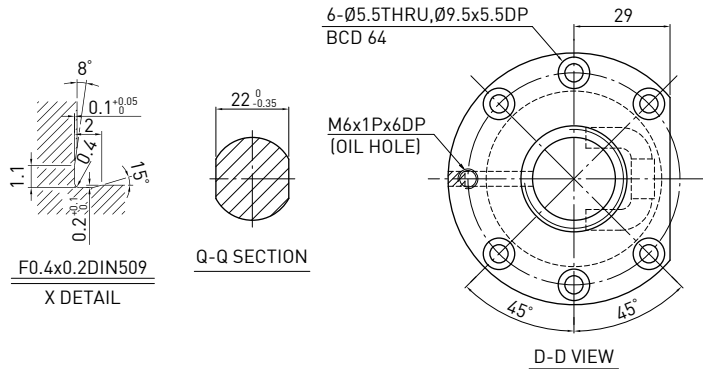

Unit : mm

Stroke	HIWIN Code	L1	L2	L3	Accuracy grade
250	R25-6B2-FSW-370-533-0.018	370	400	533	5
450	R25-6B2-FSW-570-733-0.018	570	600	733	5
650	R25-6B2-FSW-770-933-0.018	770	800	933	5

**F S W TYPE (SHAFT OD 25, LEAD 10)**

◀ Standard

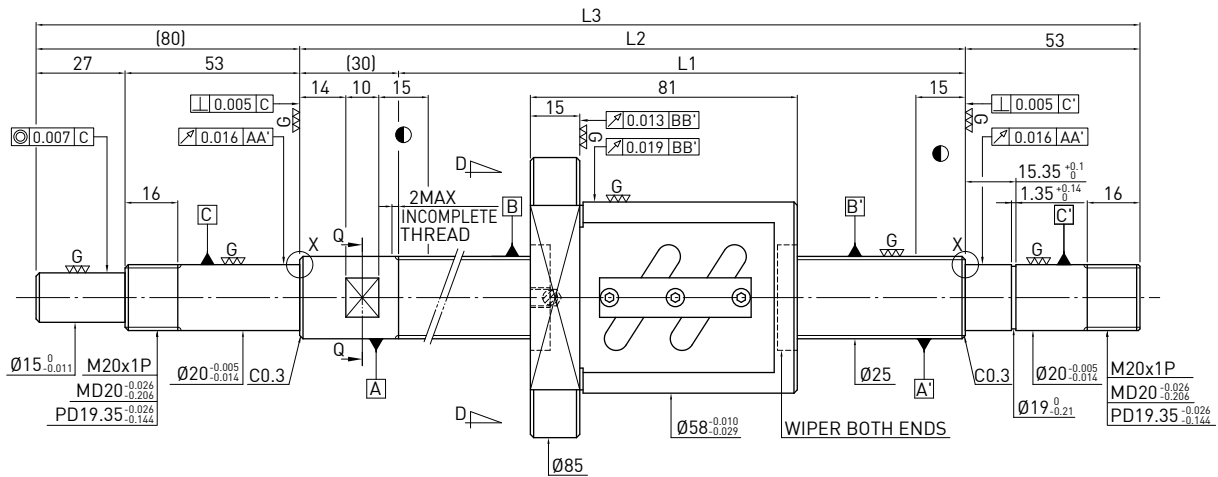

Ballscrew Data	
Direction	Right Hand
Lead (mm)	10
Lead Angle	6.98°
P.C.D (mm)	26
Screw P.C.D (mm)	26
RD (mm)	21.132
Steel Ball (mm)	$\varnothing 4.763$
Circuits	1.5x2
Dynamic Load C (Kgf)	1164
Static Load Co (Kgf)	1927
Axial Play (mm)	0
Drag Torque (Kgf-cm)	0.42-2.4
Spacer Ball	1 : 1

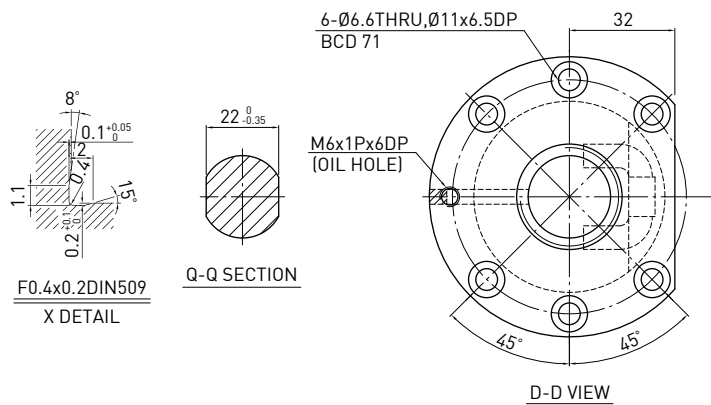

Unit : mm

Stroke	HIWIN Code	L1	L2	L3	Accuracy grade
250	R25-10A2-FSW-370-533-0.018	370	400	533	5
450	R25-10A2-FSW-570-733-0.018	570	600	733	5
650	R25-10A2-FSW-770-933-0.018	770	800	933	5
850	R25-10A2-FSW-970-1133-0.018	970	1000	1133	5
1050	R25-10A2-FSW-1170-1333-0.018	1170	1200	1333	5

**F S W** TYPE (SHAFT OD 28, LEAD 5)

◀ Standard

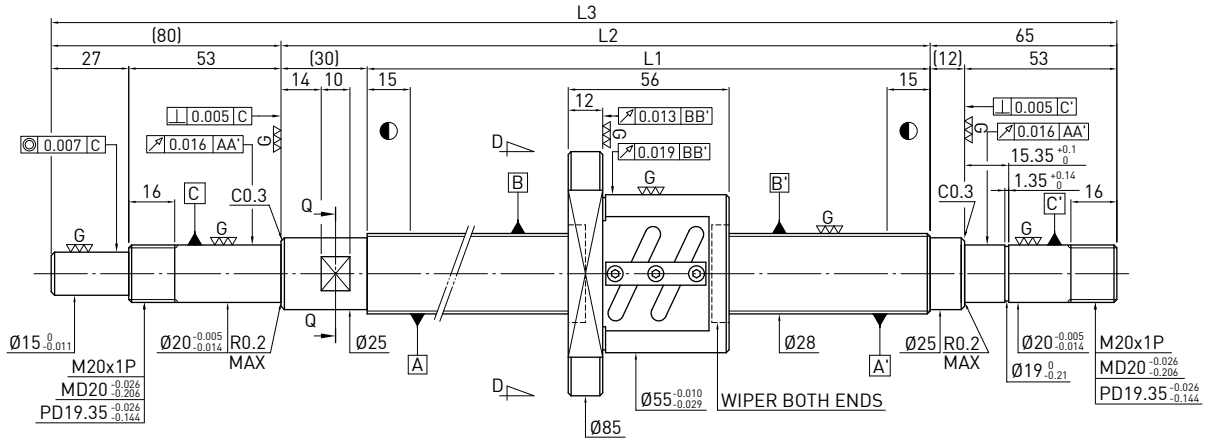

Ball screw Data	
Direction	Right Hand
Lead (mm)	5
Lead Angle	3.19°
P.C.D (mm)	28.6
Screw P.C.D (mm)	28.6
RD (mm)	25.324
Steel Ball (mm)	$\varnothing 3.175$
Circuits	2.5x2
Dynamic Load C (Kgf)	1124
Static Load Co (Kgf)	2466
Axial Play (mm)	0
Drag Torque (Kgf-cm)	0.3-1.7
Spacer Ball	1 : 1

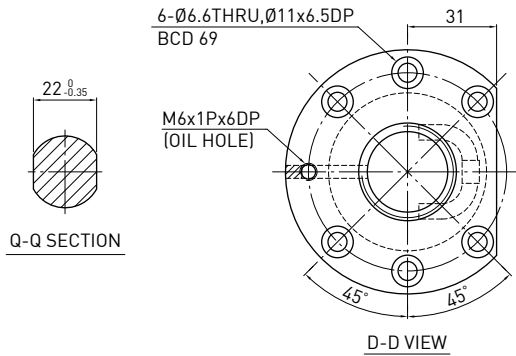

Unit : mm

Stroke	HIWIN Code	L1	L2	L3	Accuracy grade
200	R28-5B2-FSW-270-399-0.018	270	300	399	5
300	R28-5B2-FSW-370-499-0.018	370	400	499	5
400	R28-5B2-FSW-470-599-0.018	470	500	599	5
450	R28-5B2-FSW-558-733-0.018	558	600	733	5
650	R28-5B2-FSW-758-933-0.018	758	800	933	5
850	R28-5B2-FSW-958-1133-0.018	958	1000	1133	5
1050	R28-5B2-FSW-1158-1333-0.018	1158	1200	1333	5

**F S W TYPE (SHAFT OD 28, LEAD 6)**

◀ Standard

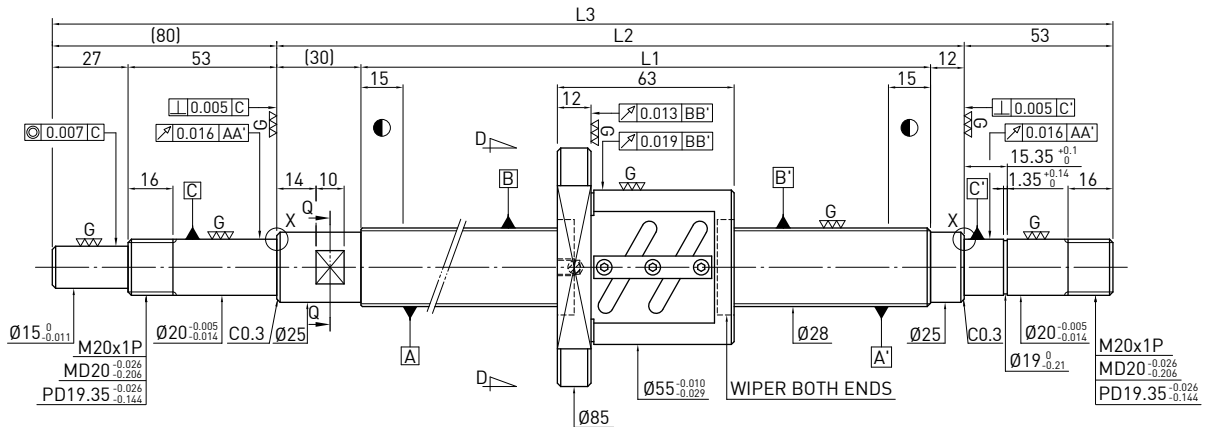

Ballscrew Data	
Direction	Right Hand
Lead (mm)	6
Lead Angle	3.82°
P.C.D (mm)	28.6
Screw P.C.D (mm)	28.6
RD (mm)	25.324
Steel Ball (mm)	Ø3.175
Circuits	2.5x2
Dynamic Load C (Kgf)	1124
Static Load Co (Kgf)	2466
Axial Play (mm)	0
Drag Torque (Kgf-cm)	0.36-2.04
Spacer Ball	1 : 1

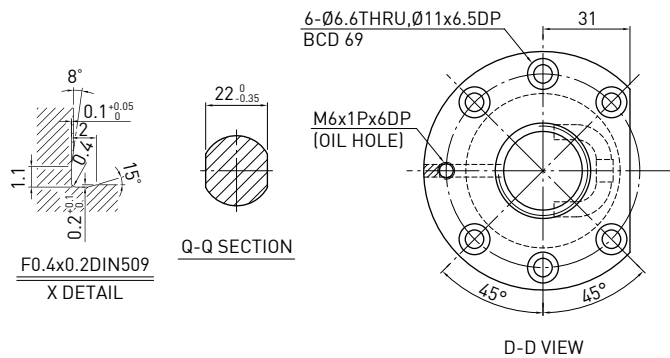

Unit : mm

Stroke	HIWIN Code	L1	L2	L3	Accuracy grade
250	R28-6B2-FSW-370-499-0.018	370	400	499	5
450	R28-6B2-FSW-570-699-0.018	570	600	699	5
650	R28-6B2-FSW-758-933-0.018	758	800	933	5
850	R28-6B2-FSW-958-1133-0.018	958	1000	1133	5
1050	R28-6B2-FSW-1158-1333-0.018	1158	1200	1333	5

**F S W** TYPE (SHAFT OD 32, LEAD 5)

◀ Standard

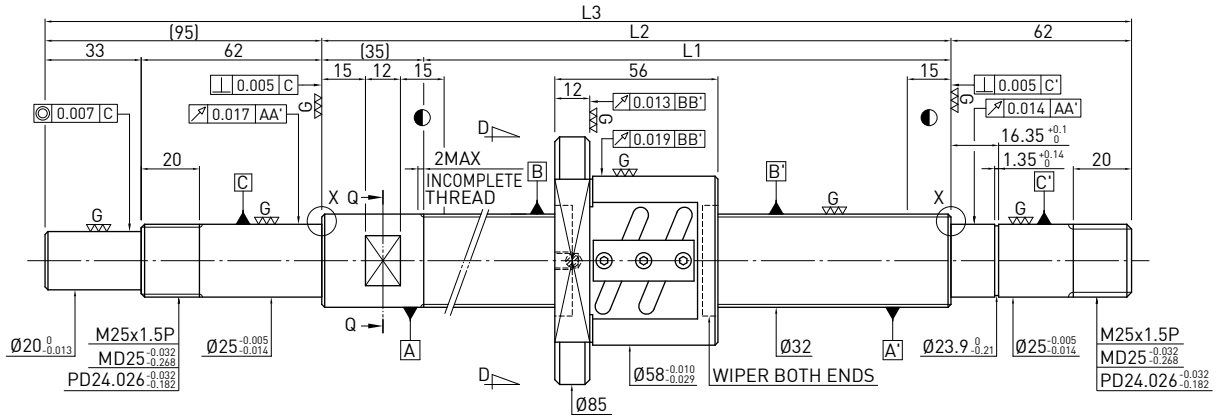

Ballscrew Data	
Direction	Right Hand
Lead (mm)	5
Lead Angle	2.79°
P.C.D (mm)	32.6
Screw P.C.D (mm)	32.6
RD (mm)	29.324
Steel Ball (mm)	Ø3.175
Circuits	2.5x2
Dynamic Load C (Kgf)	1188
Static Load Co (Kgf)	2833
Axial Play (mm)	0
Drag Torque (Kgf-cm)	0.48-1.92
Spacer Ball	1 : 1

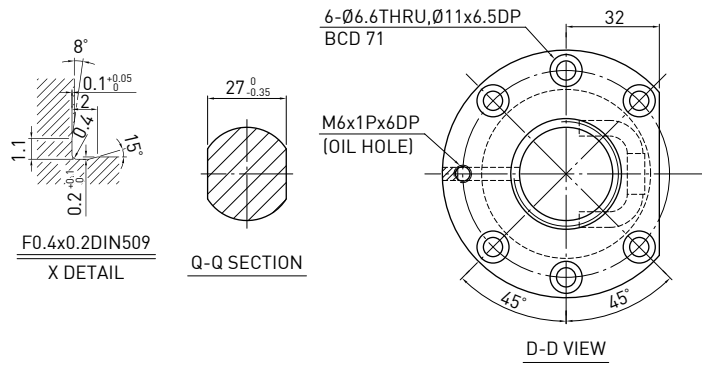

Unit : mm

Stroke	HIWIN Code	L1	L2	L3	Accuracy grade
150	R32-5B2-FSW-265-415-0.018	265	300	415	5
250	R32-5B2-FSW-365-515-0.018	365	400	515	5
350	R32-5B2-FSW-465-615-0.018	465	500	615	5
450	R32-5B2-FSW-565-715-0.018	565	600	715	5
550	R32-5B2-FSW-665-857-0.018	665	700	857	5
650	R32-5B2-FSW-765-957-0.018	765	800	957	5
850	R32-5B2-FSW-965-1157-0.018	965	1000	1157	5
1050	R32-5B2-FSW-1165-1357-0.018	1165	1200	1357	5



**F S W TYPE (SHAFT OD 32, LEAD 6)**

◀ Standard

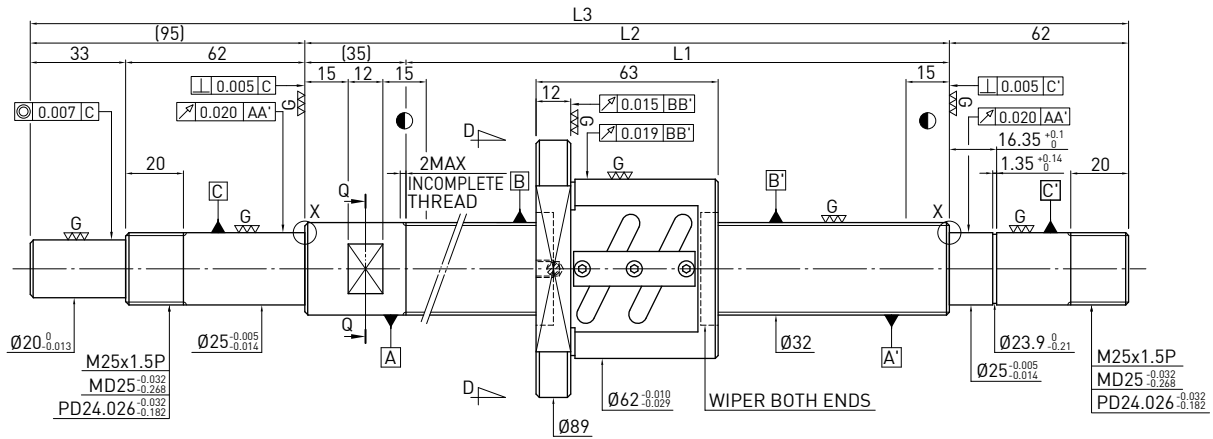

Ballscrew Data	
Direction	Right Hand
Lead (mm)	6
Lead Angle	3.33°
P.C.D (mm)	32.8
Screw P.C.D (mm)	32.8
RD (mm)	28.744
Steel Ball (mm)	Ø3.969
Circuits	2.5x2
Dynamic Load C (Kgf)	1610
Static Load Co (Kgf)	3510
Axial Play (mm)	0
Drag Torque (Kgf-cm)	0.48-2.72
Spacer Ball	1 : 1

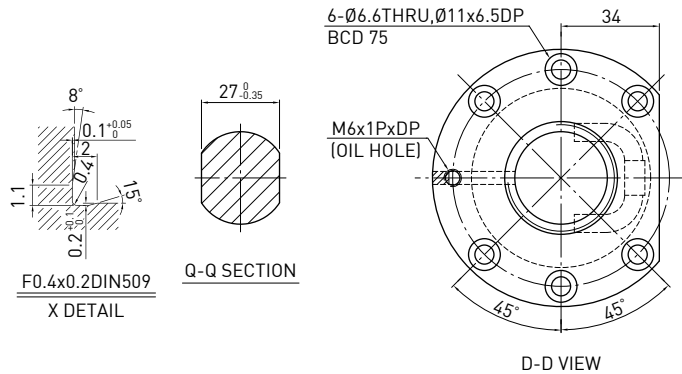

Unit : mm

Stroke	HIWIN Code	L1	L2	L3	Accuracy grade
250	R32-6B2-FSW-365-515-0.018	365	400	515	5
450	R32-6B2-FSW-565-715-0.018	565	600	715	5
650	R32-6B2-FSW-765-957-0.018	765	800	957	5
850	R32-6B2-FSW-965-1157-0.018	965	1000	1157	5
1050	R32-6B2-FSW-1165-1357-0.018	1165	1200	1357	5
1350	R32-6B2-FSW-1465-1657-0.018	1465	1500	1657	5

**F S V TYPE (SHAFT OD 16, LEAD 16)**

◀ Standard

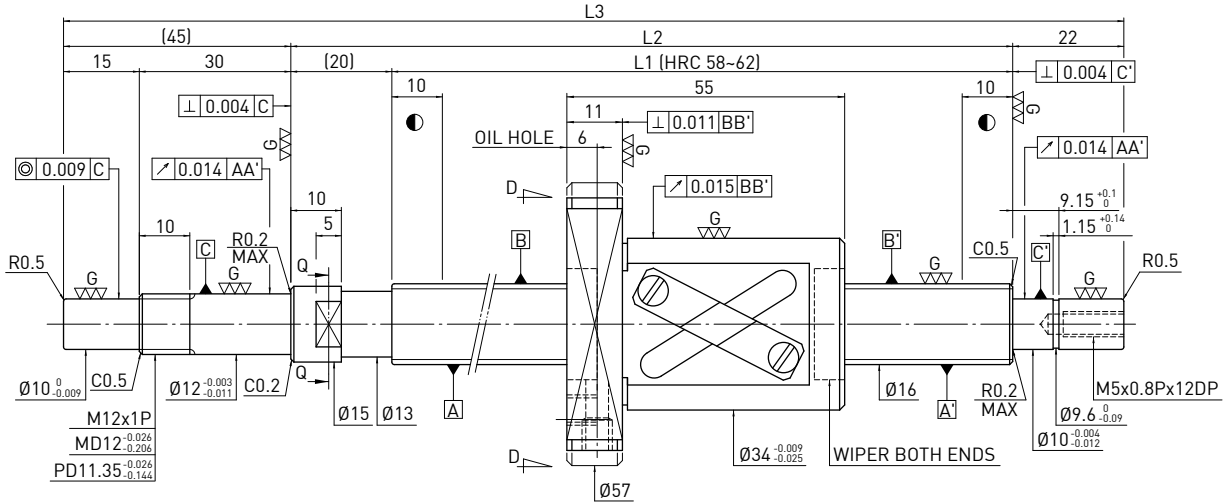

Ballscrew Data		
Direction	Right Hand	
Lead (mm)	16	
Lead Angle	17.05°	
P.C.D (mm)	16.6	
Screw P.C.D (mm)	16.6	
RD (mm)	13.324	
Steel Ball (mm)	$\varnothing 3.175$	
Circuits	1.5x1	
Dynamic Load C (Kgf)	304	481
Static Load Co (Kgf)	410	819
Axial Play (mm)	0	0.005 MAX
Drag Torque (Kgf-cm)	0.15-0.79	0.24 MAX
Spacer Ball	1 : 1	-

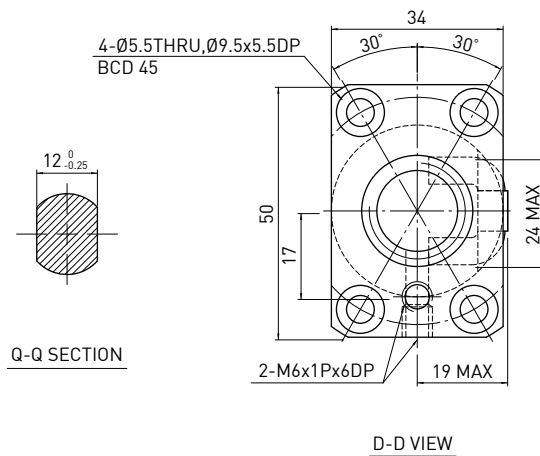

Unit : mm

Stroke	HIWIN Code	L1	L2	L3	Accuracy grade
100	R16-16A1-FSV-184-271-0.018	184	204	271	5
150	R16-16A1-FSV-234-321-0.018	234	254	321	5
200	R16-16A1-FSV-284-371-0.018	284	304	371	5
250	R16-16A1-FSV-334-421-0.018	334	354	421	5
300	R16-16A1-FSV-384-471-0.018	384	404	471	5
350	R16-16A1-FSV-434-521-0.018	434	454	521	5
400	R16-16A1-FSV-484-571-0.018	484	504	571	5
450	R16-16A1-FSV-534-621-0.018	534	554	621	5
500	R16-16A1-FSV-584-671-0.018	584	604	671	5
550	R16-16A1-FSV-634-721-0.018	634	654	721	5
600	R16-16A1-FSV-684-771-0.018	684	704	771	5
700	R16-16A1-FSV-784-871-0.018	784	804	871	5
800	R16-16A1-FSV-884-971-0.018	884	904	971	5

**F S V TYPE (SHAFT OD 25, LEAD 20)**

◀ Standard

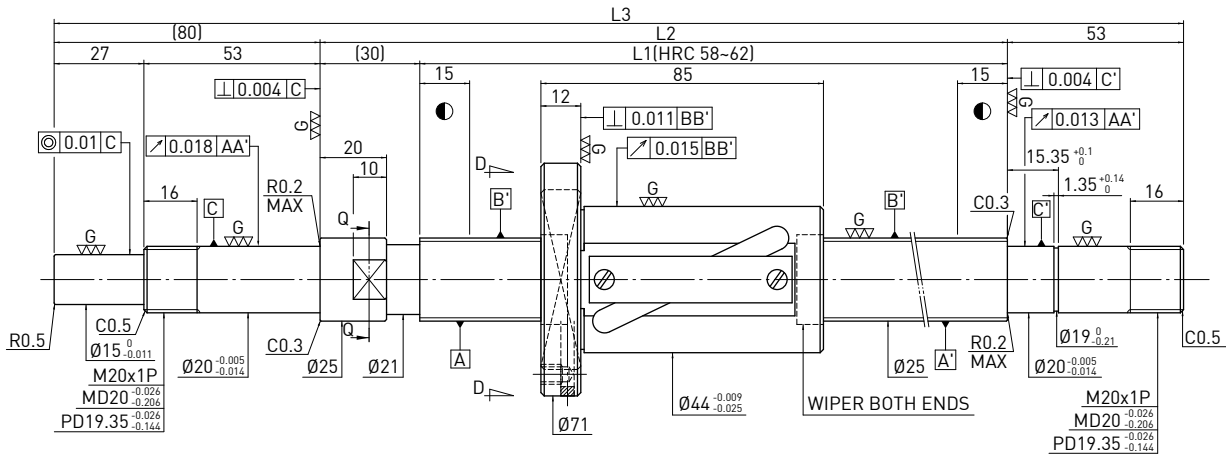

Ball screw Data		
Direction	Right Hand	
Lead (mm)	20	
Lead Angle	13.75°	
P.C.D (mm)	26	
Screw P.C.D (mm)	26	
RD (mm)	21.132	
Steel Ball (mm)	Ø4.763	
Circuits	2.5x1	
Dynamic Load C (Kgf)	1003	1591
Static Load Co (Kgf)	1619	3236
Axial Play (mm)	0	0.005 MAX
Drag Torque (Kgf-cm)	0.4~2.5	0.5 MAX
Spacer Ball	1 : 1	-

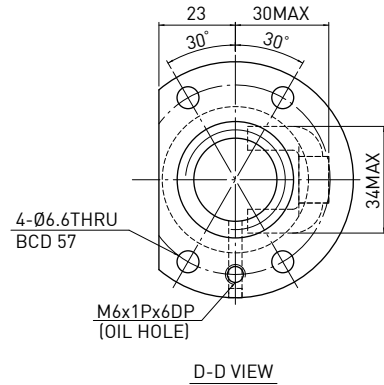
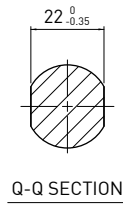

Unit : mm

Stroke	HIWIN Code	L1	L2	L3	Accuracy grade
600	R25-20B1-FSV- 750- 913-0.018	750	780	913	5
800	R25-20B1-FSV- 950- 1113-0.018	950	980	1113	5
1000	R25-20B1-FSV- 1150- 1313-0.018	1150	1180	1313	5
1200	R25-20B1-FSV- 1350- 1513-0.018	1350	1380	1513	5
1400	R25-20B1-FSV- 1550- 1713-0.018	1550	1580	1713	5
1600	R25-20B1-FSV- 1750- 1913-0.018	1750	1780	1913	5

**F S V TYPE (SHAFT OD 25, LEAD 25)**

◀ Standard

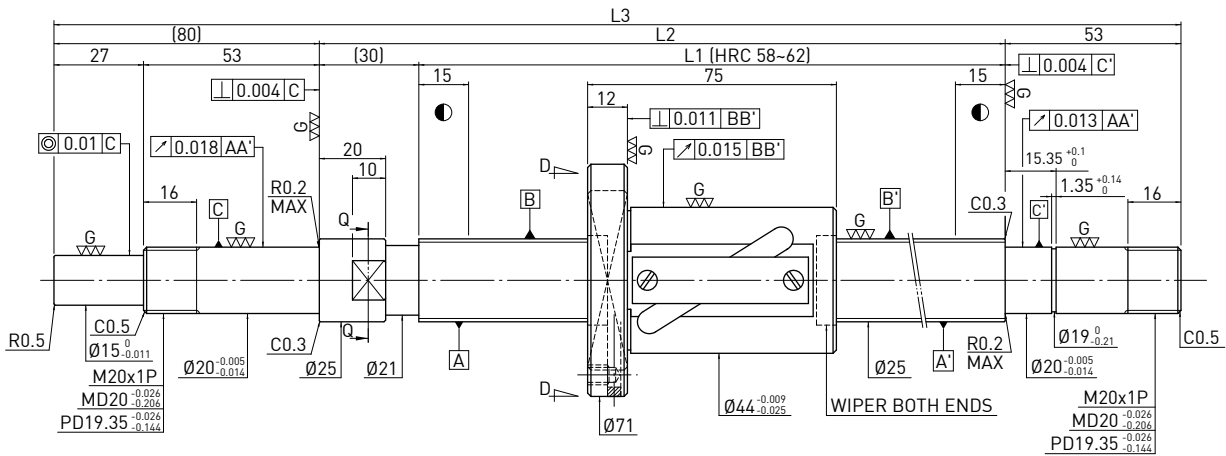

Ballscrew Data		
Direction	Right Hand	
Lead (mm)	25	
Lead Angle	17.01°	
P.C.D (mm)	26	
Screw P.C.D (mm)	26	
RD (mm)	21.132	
Steel Ball (mm)	Ø4.763	
Circuits	1.5x1	
Dynamic Load C (Kgf)	642	1018
Static Load Co (Kgf)	964	1926
Axial Play (mm)	0	0.005 MAX
Drag Torque (Kgf-cm)	0.4-2.5	0.25 MAX
Spacer Ball	1 : 1	-

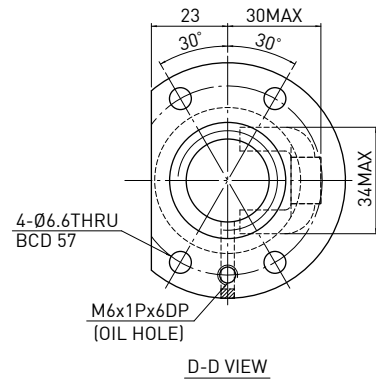
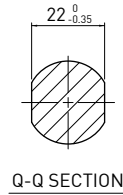

Unit : mm

Stroke	HIWIN Code	L1	L2	L3	Accuracy grade
600	R25-25A1-FSV-750-913-0.018	750	780	913	5
800	R25-25A1-FSV-950-1113-0.018	950	980	1113	5
1000	R25-25A1-FSV-1150-1313-0.018	1150	1180	1313	5
1200	R25-25A1-FSV-1350-1513-0.018	1350	1380	1513	5
1400	R25-25A1-FSV-1550-1713-0.018	1550	1580	1713	5
1600	R25-25A1-FSV-1750-1913-0.018	1750	1780	1913	5
2000	R25-25A1-FSV-2150-2313-0.018	2150	2180	2313	5

**F S V TYPE (SHAFT OD 32, LEAD 25)**

◀ Standard

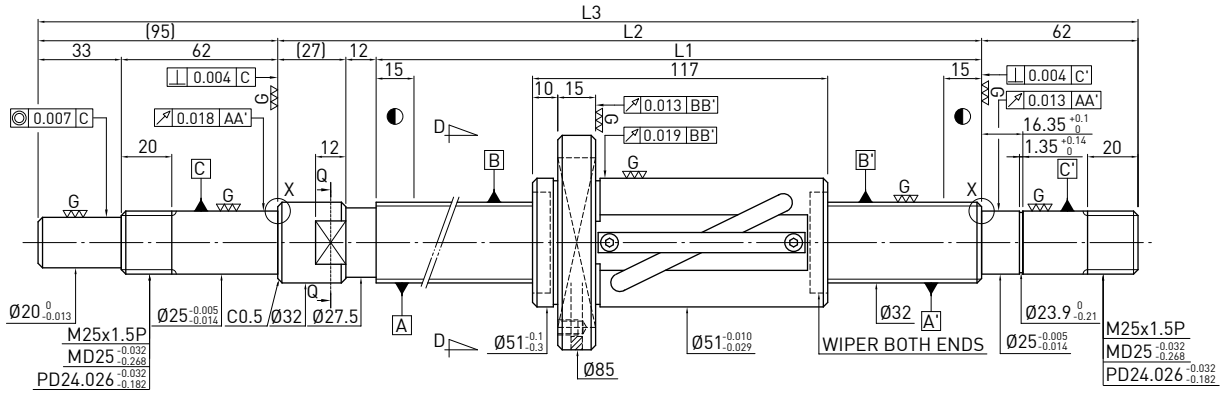

Ballscrew Data		
Direction	Right Hand	
Lead (mm)	25	
Lead Angle	13.56°	
P.C.D (mm)	33	
Screw P.C.D (mm)	33	
RD (mm)	28.132	
Steel Ball (mm)	Ø4.763	
Circuits	2.5x1	
Dynamic Load C (Kgf)	1140	1809
Static Load Co (Kgf)	2113	4226
Axial Play (mm)	0	0.005 or less
Drag Torque (Kgf-cm)	0.69-3.21	-0.8
Spacer Ball	1 : 1	-

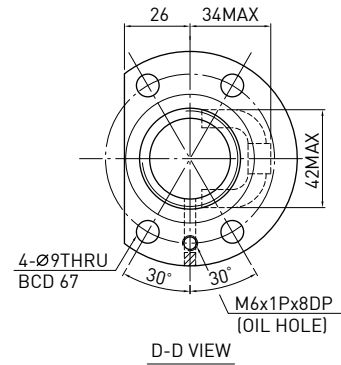
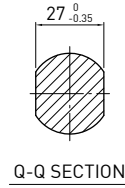
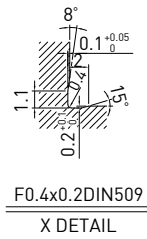

Unit : mm

Stroke	HIWIN Code	L1	L2	L3	Accuracy grade
1000	R32-25B1-FSV-1180-1376-0.018	1180	1219	1376	5
1500	R32-25B1-FSV-1680-1876-0.018	1680	1719	1876	5
2000	R32-25B1-FSV-2180-2376-0.018	2180	2219	2376	5
2600	R32-25B1-FSV-2780-2976-0.018	2780	2819	2976	5

**F S V TYPE (SHAFT OD 32, LEAD 32)**

◀ Standard

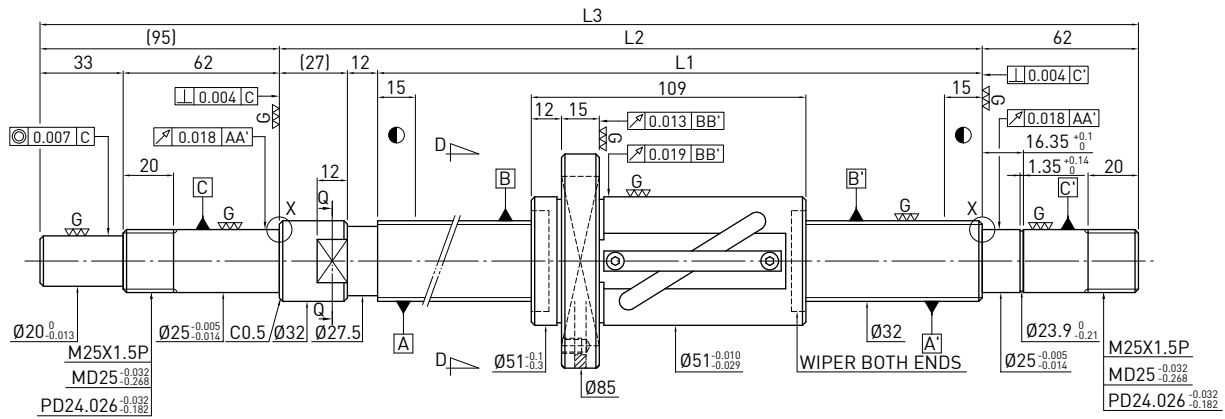

Ballscrew Data	
Direction	Right Hand
Lead (mm)	32
Lead Angle	17.15°
P.C.D (mm)	33
Screw P.C.D (mm)	33
RD (mm)	28.132
Steel Ball (mm)	$\varnothing 4.763$
Circuits	1.5x1
Dynamic Load C (Kgf)	726      1153
Static Load Co (Kgf)	1252      2504
Axial Play (mm)	0      0.005 or less
Drag Torque (Kgf-cm)	0.7~3.21      ~0.8
Spacer Ball	1 : 1      -

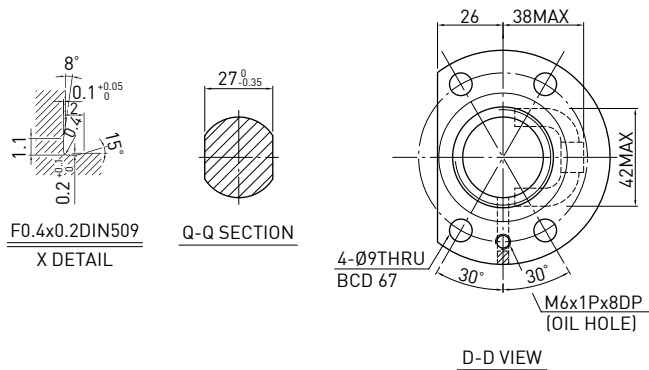

Unit : mm

Stroke	HIWIN Code	L1	L2	L3	Accuracy grade
1000	R32-32A1-FSV-1180-1376-0.018	1180	1219	1376	5
1500	R32-32A1-FSV-1680-1876-0.018	1680	1719	1876	5
2000	R32-32A1-FSV-2180-2376-0.018	2180	2219	2376	5
2600	R32-32A1-FSV-2780-2976-0.018	2780	2819	2976	5

**F D W TYPE (SHAFT OD 32, LEAD 10)**

◀ Standard

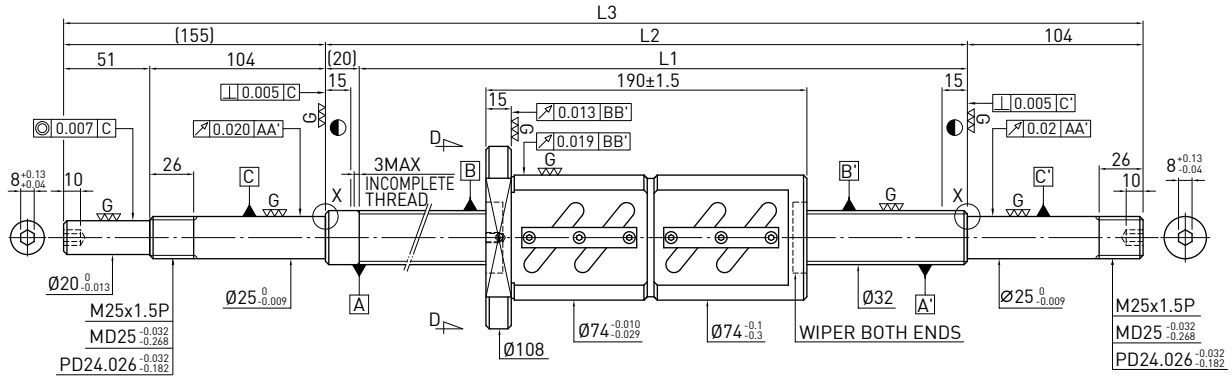

Ball screw Data	
Direction	Right Hand
Lead (mm)	10
Lead Angle	5.44°
P.C.D (mm)	33.4
Screw P.C.D (mm)	33.4
RD (mm)	26.91
Steel Ball (mm)	$\varnothing 6.35$
Circuits	2.5x2
Dynamic Load C (Kgf)	4810
Static Load Co (Kgf)	11199
Axial Play (mm)	0
Drag Torque (Kgf-cm)	5.51~11.43
Spacer Ball	-

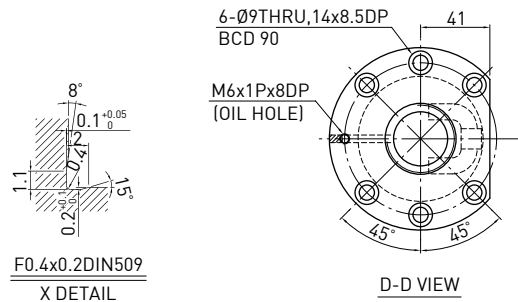

Unit : mm

Stroke	HIWIN Code	L1	L2	L3	Accuracy grade
150	R32-10B2-FDW-380-575-0.018	380	400	575	5
250	R32-10B2-FDW-480-675-0.018	480	500	675	5
350	R32-10B2-FDW-580-775-0.018	580	600	775	5
450	R32-10B2-FDW-680-959-0.018	680	700	959	5
550	R32-10B2-FDW-780-1059-0.018	780	800	1059	5
750	R32-10B2-FDW-980-1259-0.018	980	1000	1259	5
950	R32-10B2-FDW-1180-1459-0.018	1180	1200	1459	5
1250	R32-10B2-FDW-1480-1759-0.018	1480	1500	1759	5
1550	R32-10B2-FDW-1780-2059-0.018	1780	1800	2059	5

**F D W TYPE (SHAFT OD 36, LEAD 10)**

◀ Standard

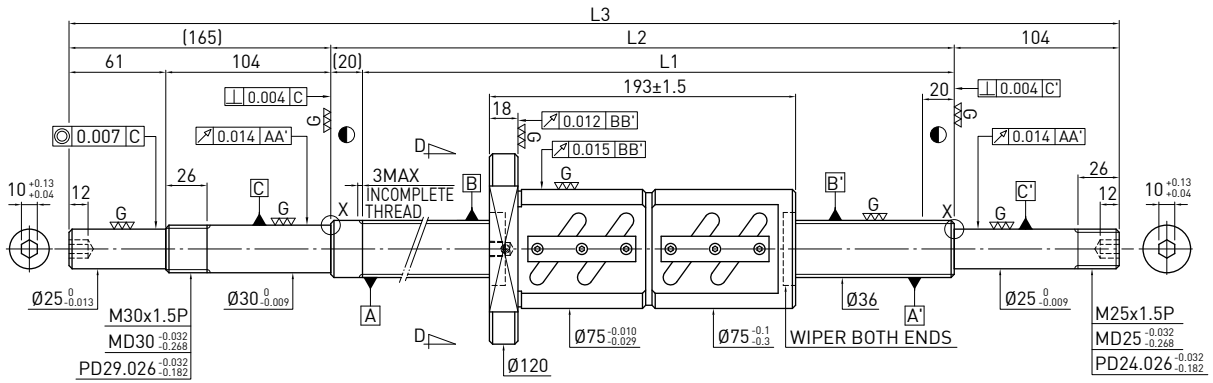

Ball screw Data	
Direction	Right Hand
Lead (mm)	10
Lead Angle	4.86°
P.C.D (mm)	37.4
Screw P.C.D (mm)	37.4
RD (mm)	30.91
Steel Ball (mm)	Ø6.35
Circuits	2.5x2
Dynamic Load C (Kgf)	5105
Static Load Co (Kgf)	12668
Axial Play (mm)	0
Drag Torque (Kgf-cm)	6.64~12.34
Spacer Ball	-

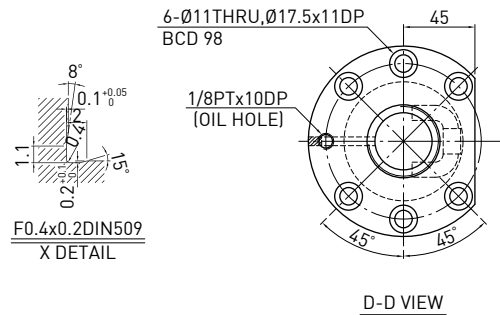

Unit : mm

Stroke	HIWIN Code	L1	L2	L3	Accuracy grade
250	R36-10B2-FDW-480-685-0.018	480	500	685	5
450	R36-10B2-FDW-680-885-0.018	680	700	885	5
750	R36-10B2-FDW-980-1269-0.018	980	1000	1269	5
1150	R36-10B2-FDW-1380-1669-0.018	1380	1400	1669	5
1550	R36-10B2-FDW-1780-2069-0.018	1780	1800	2069	5



**F D W TYPE (SHAFT OD 40, LEAD 10)**

◀ Standard

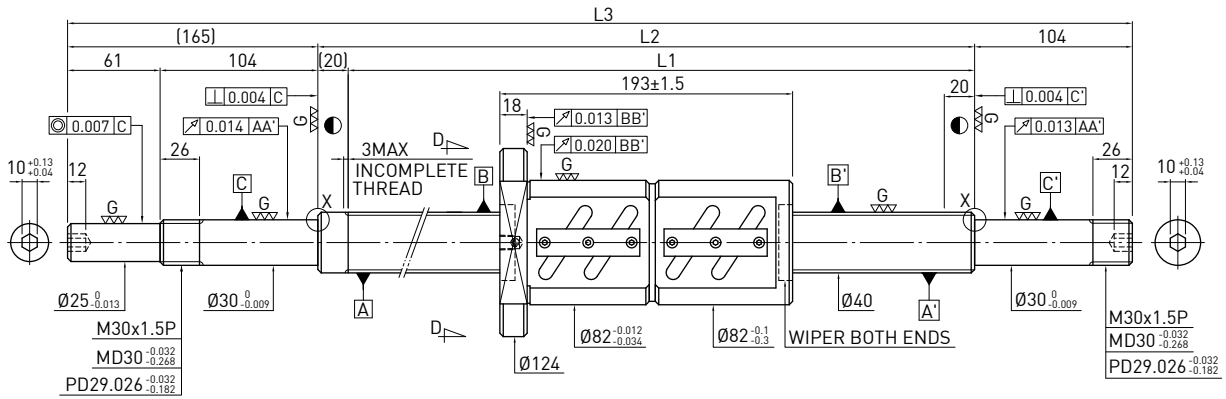

Ball screw Data	
Direction	Right Hand
Lead (mm)	10
Lead Angle	4.4°
P.C.D (mm)	41.4
Screw P.C.D (mm)	41.4
RD (mm)	34.91
Steel Ball (mm)	Ø6.35
Circuits	2.5x2
Dynamic Load C (Kgf)	5369
Static Load Co (Kgf)	14138
Axial Play (mm)	0
Drag Torque (Kgf-cm)	8.26-13.78
Spacer Ball	-

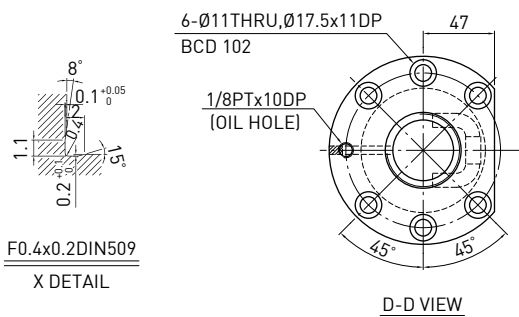

Unit : mm

Stroke	HIWIN Code	L1	L2	L3	Accuracy grade
250	R40-10B2-FDW-480-687-0.018	480	500	687	5
350	R40-10B2-FDW-580-787-0.018	580	600	787	5
450	R40-10B2-FDW-680-887-0.018	680	700	887	5
550	R40-10B2-FDW-780-1069-0.018	780	800	1069	5
750	R40-10B2-FDW-980-1269-0.018	980	1000	1269	5
950	R40-10B2-FDW-1180-1469-0.018	1180	1200	1469	5
1150	R40-10B2-FDW-1380-1669-0.018	1380	1400	1669	5
1350	R40-10B2-FDW-1580-1869-0.018	1580	1600	1869	5
1550	R40-10B2-FDW-1780-2069-0.018	1780	1800	2069	5
2150	R40-10B2-FDW-2380-2669-0.018	2380	2400	2669	5

**F D W** TYPE (SHAFT OD 40, LEAD 12)

◀ Standard

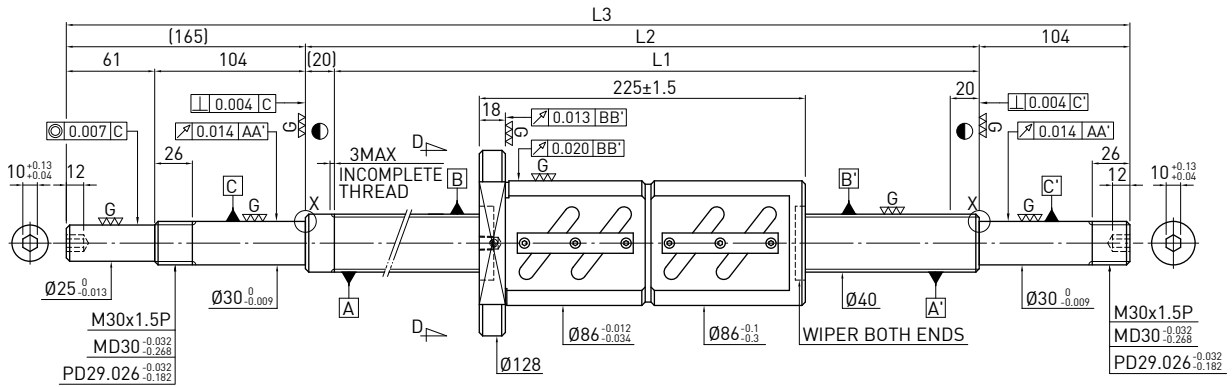

Ball screw Data	
Direction	Right Hand
Lead (mm)	12
Lead Angle	5.25°
P.C.D (mm)	41.6
Screw P.C.D (mm)	41.6
RD (mm)	34.299
Steel Ball (mm)	Ø7.144
Circuits	2.5x2
Dynamic Load C [Kgf]	6216
Static Load Co [Kgf]	15614
Axial Play (mm)	0
Drag Torque (Kgf-cm)	9.79-18.17
Spacer Ball	-

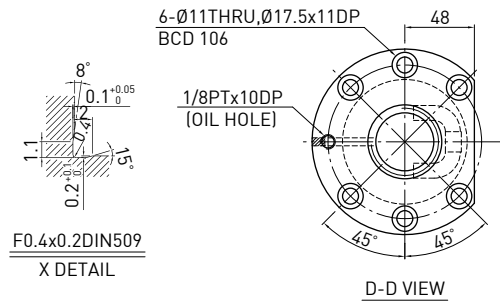

Unit : mm

Stroke	HIWIN Code	L1	L2	L3	Accuracy grade
400	R40-12B2-FDW-680-969-0.018	680	700	969	5
700	R40-12B2-FDW-980-1269-0.018	980	1000	1269	5
1100	R40-12B2-FDW-1380-1669-0.018	1380	1400	1669	5
1500	R40-12B2-FDW-1780-2069-0.018	1780	1800	2069	5
2200	R40-12B2-FDW-2480-2769-0.018	2480	2500	2769	5

**F S I** TYPE (SHAFT OD 16, LEAD 2)

◀ Standard

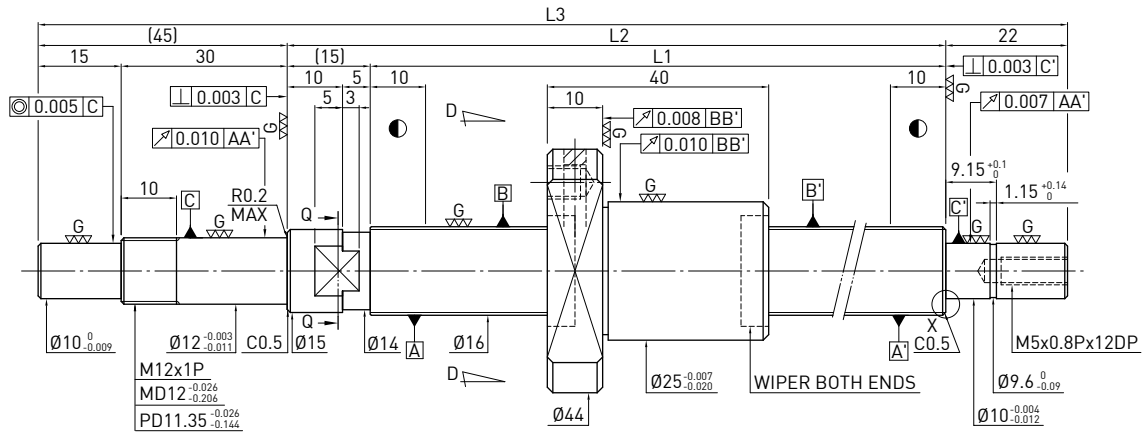

Ballscrew Data	
Direction	Right Hand
Lead (mm)	2
Lead Angle	2.25°
P.C.D (mm)	16.2
Screw P.C.D (mm)	16.2
RD (mm)	14.652
Steel Ball (mm)	Ø1.5
Circuits	1x4
Dynamic Load C (Kgf)	323
Static Load Co (Kgf)	790
Axial Play (mm)	0      0.005 or less
Drag Torque (Kgf-cm)	0.05~0.5      ~0.15
Spacer Ball	1 : 1      -

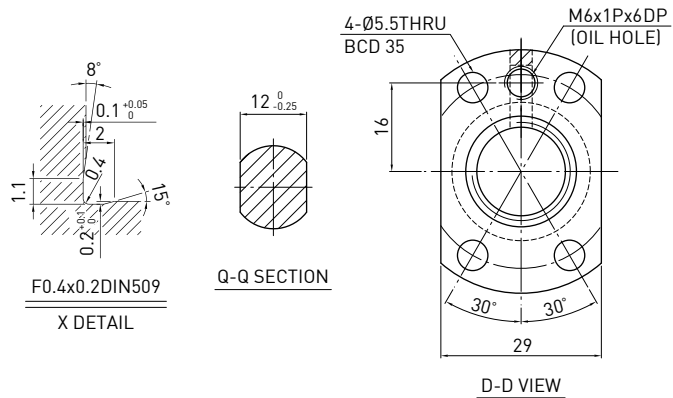

Unit : mm

Stroke	HIWIN Code	L1	L2	L3	Accuracy grade
50	R16-2T4-FSI-139-221-0.008	139	154	221	3
100	R16-2T4-FSI-189-271-0.008	189	204	271	3
150	R16-2T4-FSI-239-321-0.008	239	254	321	3
200	R16-2T4-FSI-289-371-0.008	289	304	371	3
300	R16-2T4-FSI-389-471-0.008	389	404	471	3

**F S I** TYPE (SHAFT OD 16, LEAD 2.5)

Standard

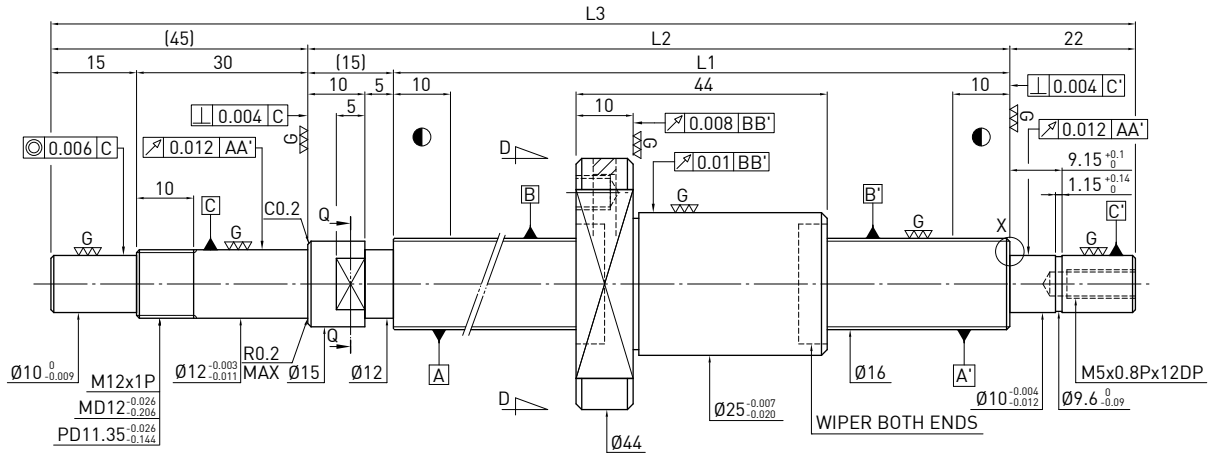

Ballscrew Data	
Direction	Right Hand
Lead (mm)	2.5
Lead Angle	2.81°
P.C.D (mm)	16.2
Screw P.C.D (mm)	16.2
RD (mm)	14.652
Steel Ball (mm)	$\varnothing 1.5$
Circuits	1x4
Dynamic Load C (Kgf)	323
Static Load Co (Kgf)	790
Axial Play (mm)	0      0.005 or less
Drag Torque (Kgf-cm)	0.05~0.5      ~0.15
Spacer Ball	-      -

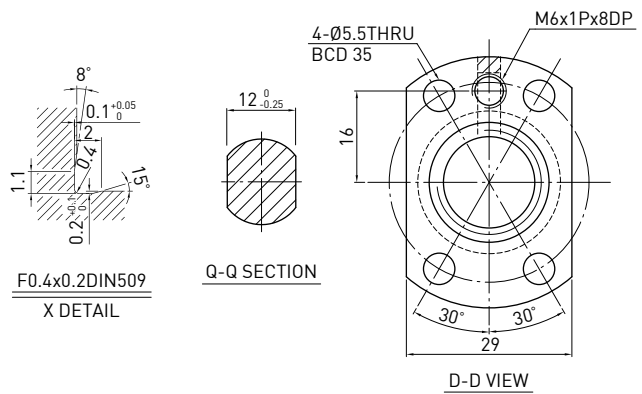

Unit : mm

Stroke	HIWIN Code	L1	L2	L3	Accuracy grade
50	R16-2.5T4-FSI-139-221-0.008	139	154	221	3
100	R16-2.5T4-FSI-189-271-0.008	189	204	271	3
150	R16-2.5T4-FSI-239-321-0.008	239	254	321	3
200	R16-2.5T4-FSI-289-371-0.008	289	304	371	3
300	R16-2.5T4-FSI-389-471-0.008	389	404	471	3

**O F S W TYPE (SHAFT OD 16, LEAD 2)**

◀ Standard

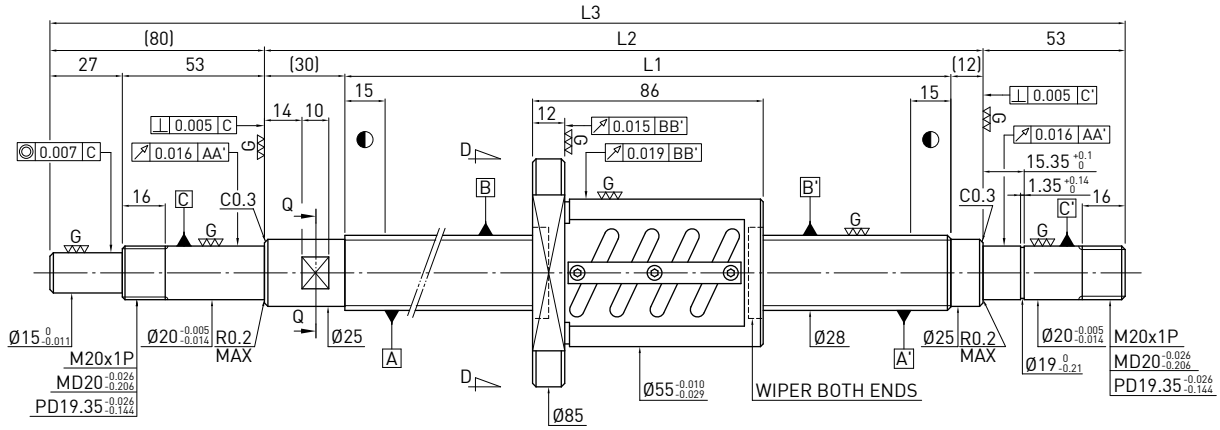

Ballscrew Data	
Direction	Right Hand
Lead (mm)	5
Lead Angle	3.19°
P.C.D (mm)	28.6
Screw P.C.D (mm)	28.6
RD (mm)	25.324
Steel Ball (mm)	Ø3.175
Circuits	2.5x2
Dynamic Load C (Kgf)	1784
Static Load Co (Kgf)	4932
Axial Play (mm)	0
Drag Torque (Kgf-cm)	1.1-3.3
Spacer Ball	-

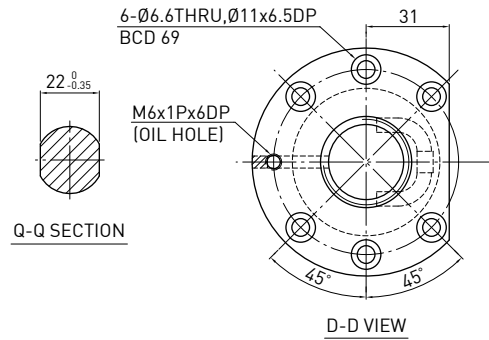

Unit : mm

Stroke	HIWIN Code	L1	L2	L3	Accuracy grade
150	R28-5B2-OFSW-270-399-0.018	270	300	399	5
250	R28-5B2-OFSW-370-499-0.018	370	400	499	5
350	R28-5B2-OFSW-470-599-0.018	470	500	599	5
450	R28-5B2-OFSW-558-733-0.018	558	600	733	5
650	R28-5B2-OFSW-758-933-0.018	758	800	933	5
850	R28-5B2-OFSW-958-1133-0.018	958	1000	1133	5
1050	R28-5B2-OFSW-1158-1333-0.018	1158	1200	1333	5

**O F S W** TYPE (SHAFT OD 28, LEAD 6)

◀ Standard

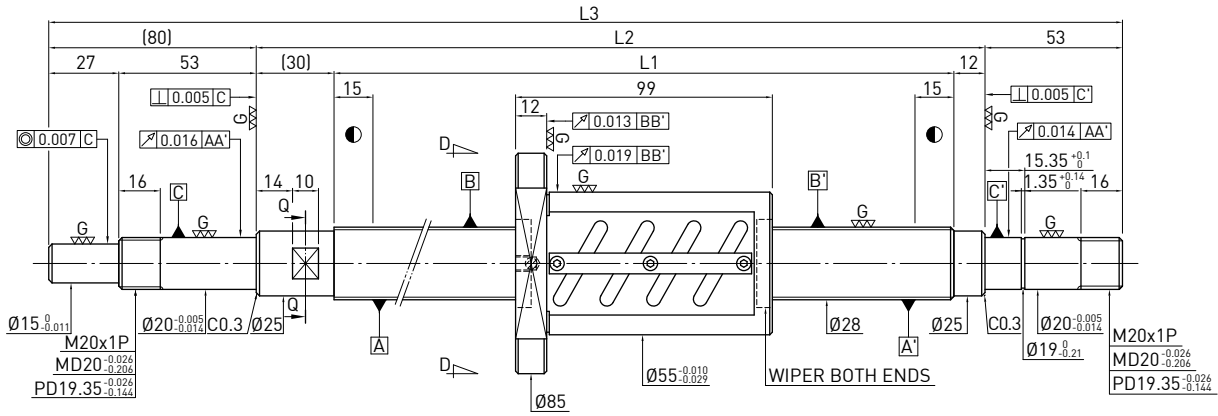

Ball screw Data	
Direction	Right Hand
Lead (mm)	6
Lead Angle	3.82°
P.C.D (mm)	28.6
Screw P.C.D (mm)	28.6
RD (mm)	25.324
Steel Ball (mm)	Ø3.175
Circuits	2.5x2
Dynamic Load C (Kgf)	1784
Static Load Co (Kgf)	4932
Axial Play (mm)	0
Drag Torque (Kgf-cm)	1.2-3.6
Spacer Ball	-

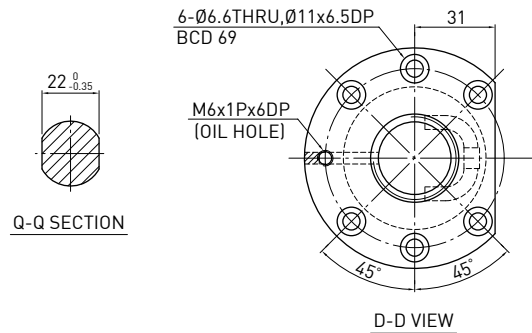

Unit : mm

Stroke	HIWIN Code	L1	L2	L3	Accuracy grade
250	R28-6B2-OFSW-370-499-0.018	370	400	499	5
450	R28-6B2-OFSW-570-699-0.018	570	600	699	5
650	R28-6B2-OFSW-758-933-0.018	758	800	933	5
850	R28-6B2-OFSW-958-1133-0.018	958	1000	1133	5
1050	R28-6B2-OFSW-1158-1333-0.018	1158	1200	1333	5

**O F S W** TYPE (SHAFT OD 32, LEAD 5)

◀ Standard

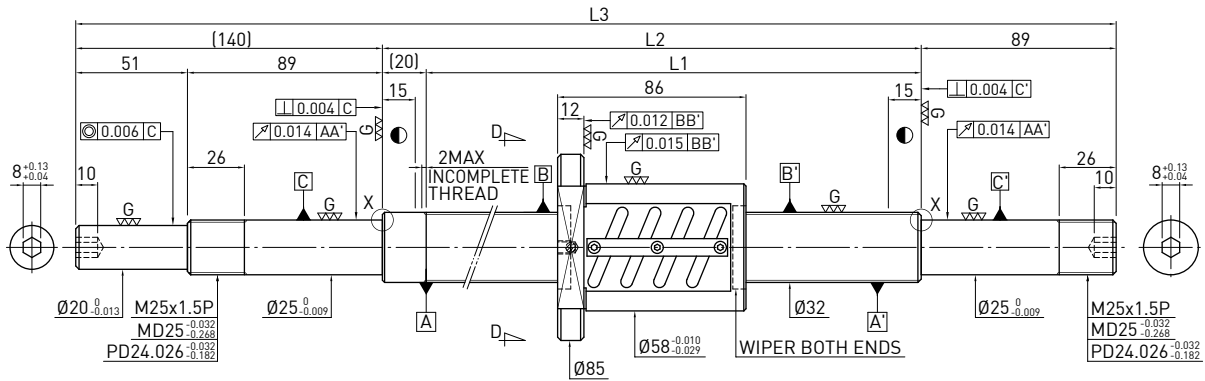

Ball screw Data	
Direction	Right Hand
Lead (mm)	5
Lead Angle	2.79°
P.C.D (mm)	32.6
Screw P.C.D (mm)	32.6
RD (mm)	29.324
Steel Ball (mm)	Ø3.175
Circuits	2.5x2
Dynamic Load C (Kgf)	1886
Static Load Co (Kgf)	5666
Axial Play (mm)	0
Drag Torque (Kgf-cm)	1.2-3.6
Spacer Ball	-

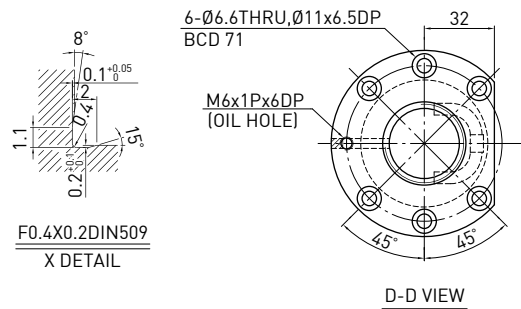

Unit : mm

Stroke	HIWIN Code	L1	L2	L3	Accuracy grade
150	R32-5B2-0FSW-280-460-0.018	280	300	460	5
250	R32-5B2-0FSW-380-560-0.018	380	400	560	5
350	R32-5B2-0FSW-480-660-0.018	480	500	660	5
450	R32-5B2-0FSW-580-760-0.018	580	600	760	5
550	R32-5B2-0FSW-680-929-0.018	680	700	929	5
650	R32-5B2-0FSW-780-1029-0.018	780	800	1029	5
850	R32-5B2-0FSW-980-1229-0.018	980	1000	1229	5
1050	R32-5B2-0FSW-1180-1429-0.018	1180	1200	1429	5
1350	R32-5B2-0FSW-1480-1729-0.018	1480	1500	1729	5

**O F S W** TYPE (SHAFT OD 32, LEAD 6)

◀ Standard

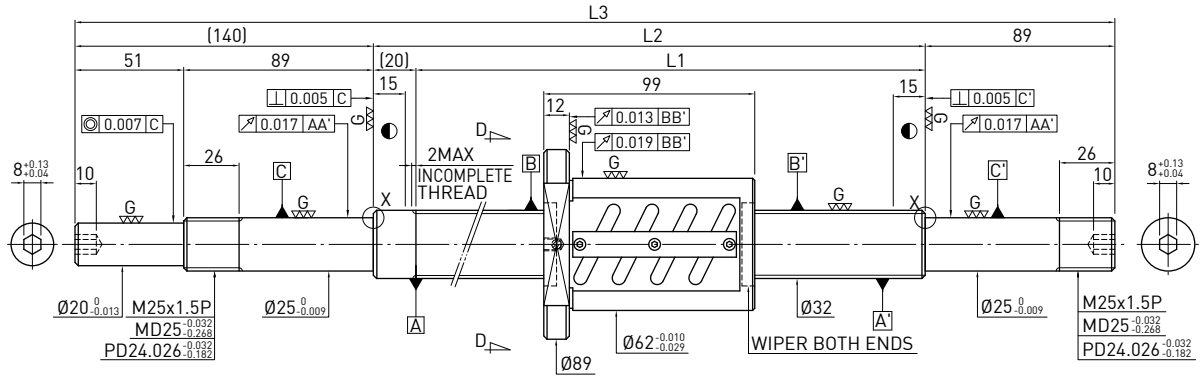

Ball screw Data	
Direction	Right Hand
Lead (mm)	6
Lead Angle	3.33°
P.C.D (mm)	32.8
Screw P.C.D (mm)	32.8
RD (mm)	28.744
Steel Ball (mm)	Ø3.969
Circuits	2.5x2
Dynamic Load C (Kgf)	2556
Static Load Co (Kgf)	7019
Axial Play (mm)	0
Drag Torque (Kgf-cm)	2.32-4.82
Spacer Ball	-

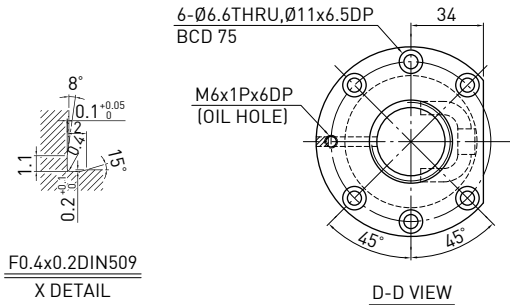

Unit : mm

Stroke	HIWIN Code	L1	L2	L3	Accuracy grade
250	R32-6B2-OFSW-380-560-0.018	380	400	560	5
450	R32-6B2-OFSW-580-760-0.018	580	600	760	5
650	R32-6B2-OFSW-780-1029-0.018	780	800	1029	5
850	R32-6B2-OFSW-980-1229-0.018	980	1000	1229	5
1050	R32-6B2-OFSW-1180-1429-0.018	1180	1200	1429	5
1350	R32-6B2-OFSW-1480-1729-0.018	1480	1500	1729	5



**OFSW** TYPE (SHAFT OD 32, LEAD 8)

◀ Standard

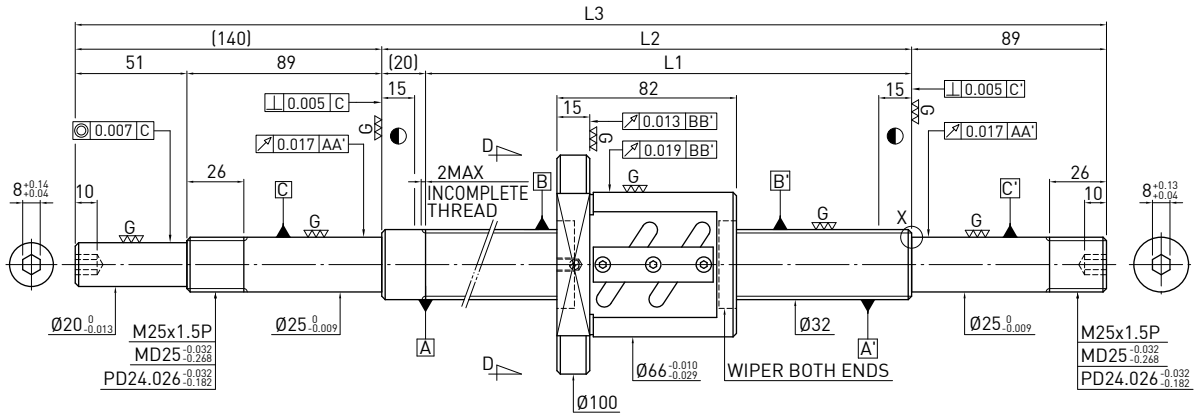

Ball screw Data	
Direction	Right Hand
Lead (mm)	8
Lead Angle	4.41°
P.C.D (mm)	33
Screw P.C.D (mm)	33
RD (mm)	28.132
Steel Ball (mm)	Ø4.763
Circuits	2.5x1
Dynamic Load C (Kgf)	2650
Static Load Co (Kgf)	5599
Axial Play (mm)	0
Drag Torque (Kgf-cm)	1.26-5.06
Spacer Ball	-

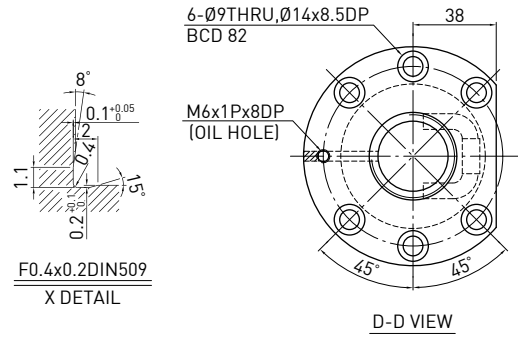

Unit : mm

Stroke	HIWIN Code	L1	L2	L3	Accuracy grade
250	R32-8B1-OFSW-380-560-0.018	380	400	560	5
450	R32-8B1-OFSW-580-760-0.018	580	600	760	5
650	R32-8B1-OFSW-780-1029-0.018	780	800	1029	5
850	R32-8B1-OFSW-980-1229-0.018	980	1000	1229	5
1350	R32-8B1-OFSW-1480-1729-0.018	1480	1500	1729	5
1350	R32-6B2-OFSW-1480-1729-0.018	1480	1500	1729	5

**O F S W** TYPE (SHAFT OD 32, LEAD 10)

◀ Standard

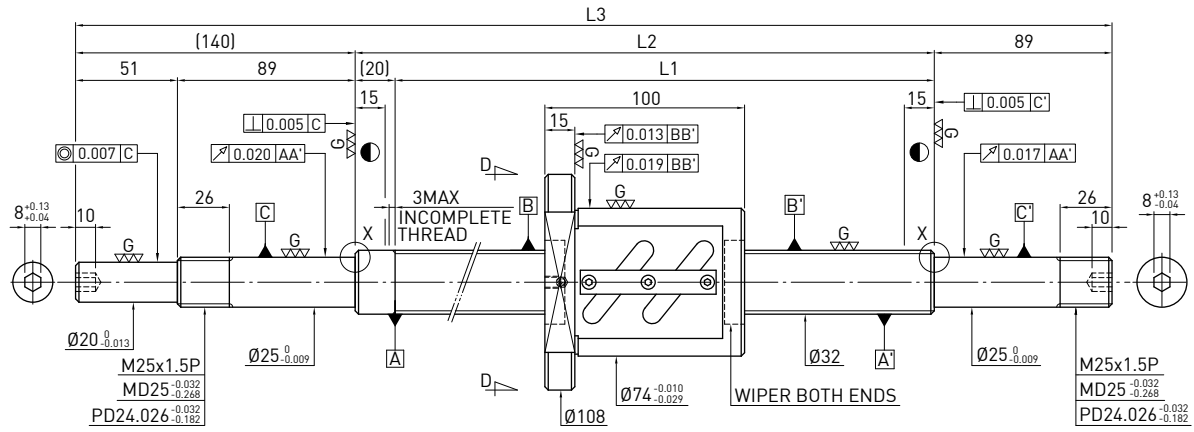

Ball screw Data	
Direction	Right Hand
Lead (mm)	10
Lead Angle	5.44°
P.C.D (mm)	33.4
Screw P.C.D (mm)	33.4
RD (mm)	26.91
Steel Ball (mm)	Ø6.35
Circuits	2.5x1
Dynamic Load C (Kgf)	2650
Static Load Co (Kgf)	5599
Axial Play (mm)	0
Drag Torque (Kgf-cm)	3.58-7.44
Spacer Ball	-

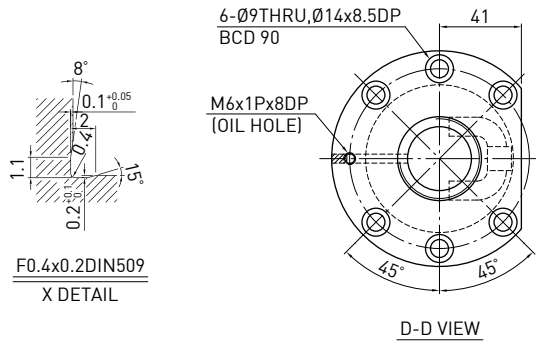

Unit : mm

Stroke	HIWIN Code	L1	L2	L3	Accuracy grade
250	R32-10B1-OFSW-380-560-0.018	380	400	560	5
350	R32-10B1-OFSW-480-660-0.018	480	500	660	5
450	R32-10B1-OFSW-580-760-0.018	580	600	760	5
550	R32-10B1-OFSW-680-929-0.018	680	700	929	5
650	R32-10B1-OFSW-780-1029-0.018	780	800	1029	5
850	R32-10B1-OFSW-980-1229-0.018	980	1000	1229	5
1050	R32-10B1-OFSW-1180-1429-0.018	1180	1200	1429	5
1350	R32-10B1-OFSW-1480-1729-0.018	1480	1500	1729	5
1650	R32-10B1-OFSW-1780-2029-0.018	1780	1800	2029	5

**O F S W TYPE (SHAFT OD 36, LEAD 10)**

◀ Standard

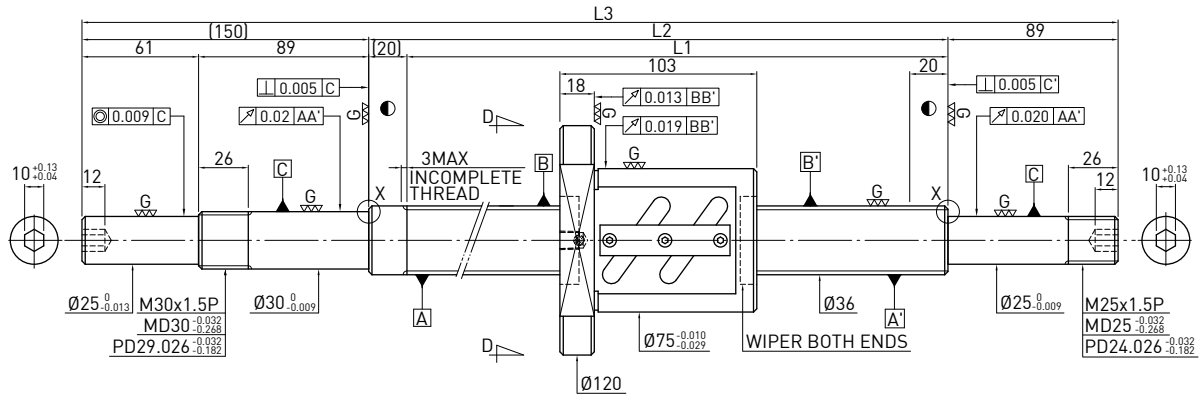

Ball screw Data	
Direction	Right Hand
Lead (mm)	10
Lead Angle	4.84°
P.C.D (mm)	37.4
Screw P.C.D (mm)	37.4
RD (mm)	30.91
Steel Ball (mm)	Ø6.35
Circuits	2.5x1
Dynamic Load C (Kgf)	2812
Static Load Co (Kgf)	6334
Axial Play (mm)	0
Drag Torque (Kgf-cm)	3.91-8.13
Spacer Ball	-

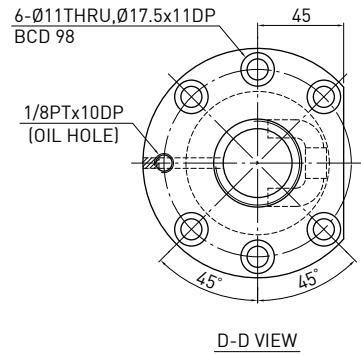
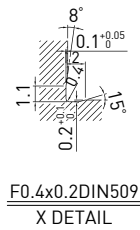

Unit : mm

Stroke	HIWIN Code	L1	L2	L3	Accuracy grade
350	R36-10B1-OFSW-480-670-0.018	480	500	670	5
550	R36-10B1-OFSW-680-870-0.018	680	700	870	5
850	R36-10B1-OFSW-980-1239-0.018	980	1000	1239	5
1250	R36-10B1-OFSW-1380-1639-0.018	1380	1400	1639	5
1650	R36-10B1-OFSW-1780-2039-0.018	1780	1800	2039	5

**OFSW** TYPE (SHAFT OD 40, LEAD 5)

◀ Standard

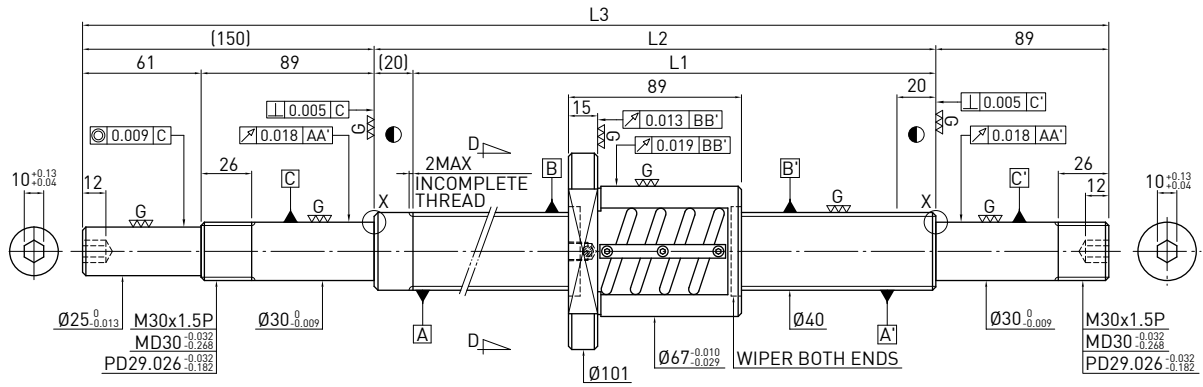

Ball screw Data	
Direction	Right Hand
Lead (mm)	5
Lead Angle	$2.24^\circ$
P.C.D (mm)	40.6
Screw P.C.D (mm)	40.6
RD (mm)	37.324
Steel Ball (mm)	$\varnothing 3.175$
Circuits	2.5x2
Dynamic Load C (Kgf)	2070
Static Load Co (Kgf)	7134
Axial Play (mm)	0
Drag Torque (Kgf-cm)	1.81-4.21
Spacer Ball	-

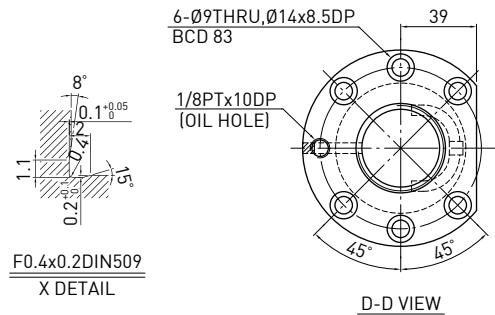

Unit : mm

Stroke	HIWIN Code	L1	L2	L3	Accuracy grade
250	R40-5B2-OFSW-380-572-0.018	380	400	572	5
450	R40-5B2-OFSW-580-772-0.018	580	600	772	5
650	R40-5B2-OFSW-780-1039-0.018	780	800	1039	5
850	R40-5B2-OFSW-980-1239-0.018	980	1000	1239	5
1050	R40-5B2-OFSW-1180-1439-0.018	1180	1200	1439	5
1450	R40-5B2-OFSW-1580-1839-0.018	1580	1600	1839	5

**O F S W TYPE (SHAFT OD 40, LEAD 8)**

◀ Standard

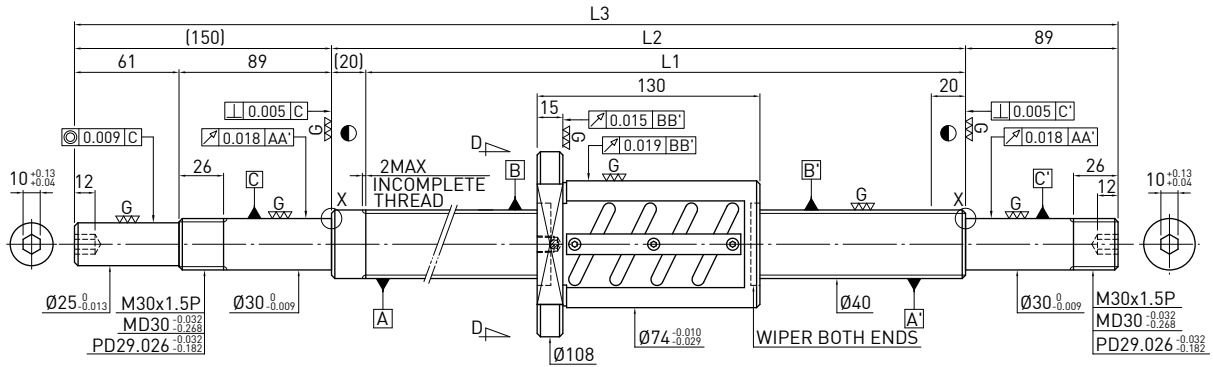

Ball screw Data	
Direction	Right Hand
Lead (mm)	8
Lead Angle	3.55°
P.C.D (mm)	41
Screw P.C.D (mm)	41
RD (mm)	36.132
Steel Ball (mm)	Ø4.763
Circuits	2.5x2
Dynamic Load C (Kgf)	3634
Static Load Co (Kgf)	10603
Axial Play (mm)	0
Drag Torque (Kgf-cm)	4.24-8.82
Spacer Ball	-

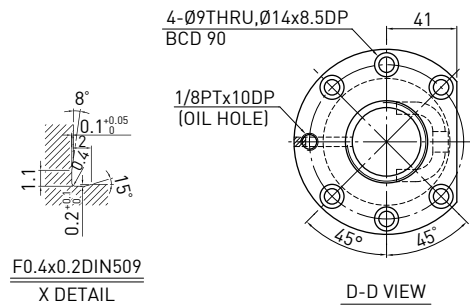

Unit : mm

Stroke	HIWIN Code	L1	L2	L3	Accuracy grade
200	R40-8B2-OFSW-380-572-0.018	380	400	572	5
400	R40-8B2-OFSW-580-772-0.018	580	600	772	5
600	R40-8B2-OFSW-780-1039-0.018	780	800	1039	5
800	R40-8B2-OFSW-980-1239-0.018	980	1000	1239	5
1000	R40-8B2-OFSW-1180-1439-0.018	1180	1200	1439	5
1400	R40-8B2-OFSW-1580-1839-0.018	1580	1600	1839	5

**O F S W** TYPE (SHAFT OD 40, LEAD 10)

◀ Standard

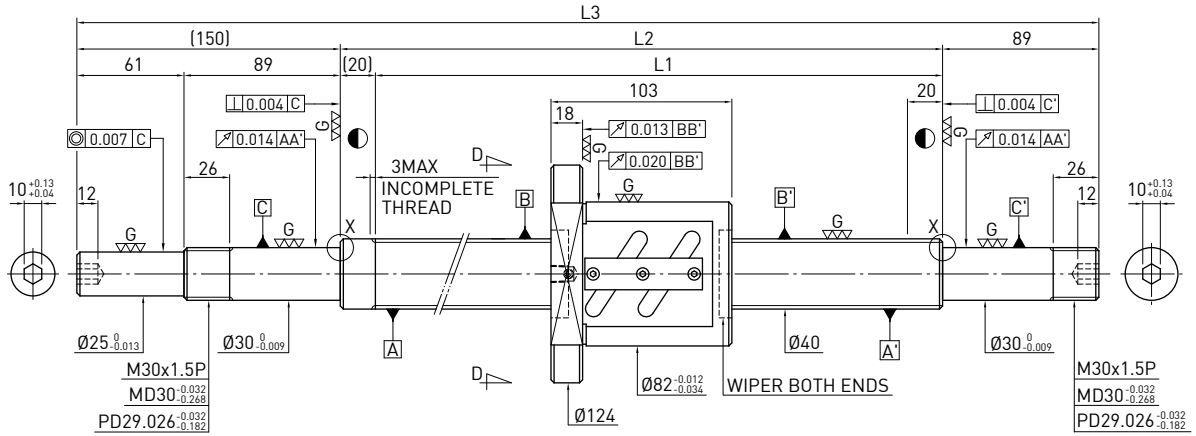

Ball screw Data	
Direction	Right Hand
Lead (mm)	10
Lead Angle	4.4°
P.C.D (mm)	41.4
Screw P.C.D (mm)	41.4
RD (mm)	34.91
Steel Ball (mm)	$\varnothing 6.35$
Circuits	2.5x1
Dynamic Load C (Kgf)	2958
Static Load Co (Kgf)	7069
Axial Play (mm)	0
Drag Torque (Kgf-cm)	4.57-8.49
Spacer Ball	-

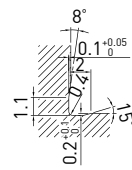

F0.4x0.2DIN509  
X DETAIL

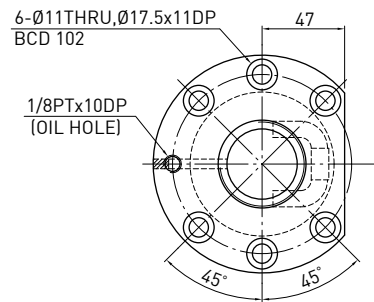

D-D VIEW

Unit : mm

Stroke	HIWIN Code	L1	L2	L3	Accuracy grade
350	R40-10B1-OFSW-480-672-0.018	480	500	672	5
450	R40-10B1-OFSW-580-772-0.018	580	600	772	5
550	R40-10B1-OFSW-680-872-0.018	680	700	872	5
650	R40-10B1-OFSW-780-1039-0.018	780	800	1039	5
850	R40-10B1-OFSW-980-1239-0.018	980	1000	1239	5
1050	R40-10B1-OFSW-1180-1439-0.018	1180	1200	1439	5
1250	R40-10B1-OFSW-1380-1639-0.018	1380	1400	1639	5
1450	R40-10B1-OFSW-1580-1839-0.018	1580	1600	1839	5
1650	R40-10B1-OFSW-1780-2039-0.018	1780	1800	2039	5
2250	R40-10B1-OFSW-2380-2639-0.018	2380	2400	2639	5

**OFSW** TYPE (SHAFT OD 40, LEAD 12)

◀ Standard

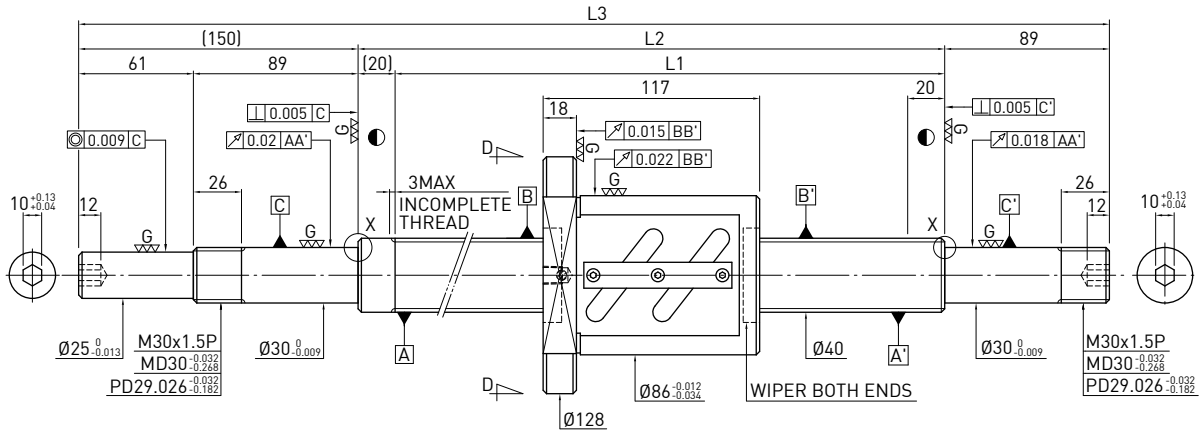

Ball screw Data	
Direction	Right Hand
Lead (mm)	12
Lead Angle	5.25°
P.C.D (mm)	41.6
Screw P.C.D (mm)	41.6
RD (mm)	34.299
Steel Ball (mm)	$\varnothing 7.144$
Circuits	2.5x1
Dynamic Load C (Kgf)	3425
Static Load Co (Kgf)	7837
Axial Play (mm)	0
Drag Torque (Kgf-cm)	5.93-11.01
Spacer Ball	-

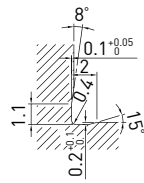

F0.4x0.2DIN509  
X-DETAIL

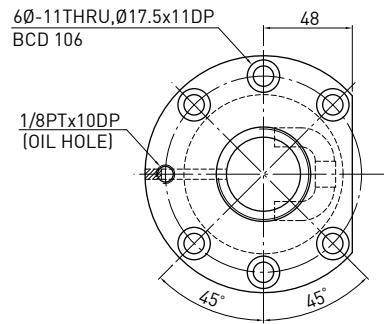

D-D VIEW

Unit : mm

Stroke	HIWIN Code	L1	L2	L3	Accuracy grade
500	R40-12B1-OFSW-680-939-0.018	680	700	939	5
800	R40-12B1-OFSW-980-1239-0.018	980	1000	1239	5
1200	R40-12B1-OFSW-1380-1639-0.018	1380	1400	1639	5
1600	R40-12B1-OFSW-1780-2039-0.018	1780	1800	2039	5
2300	R40-12B1-OFSW-2480-2739-0.018	2480	2500	2739	5

**O F S W** TYPE (SHAFT OD 45, LEAD 10)

◀ Standard

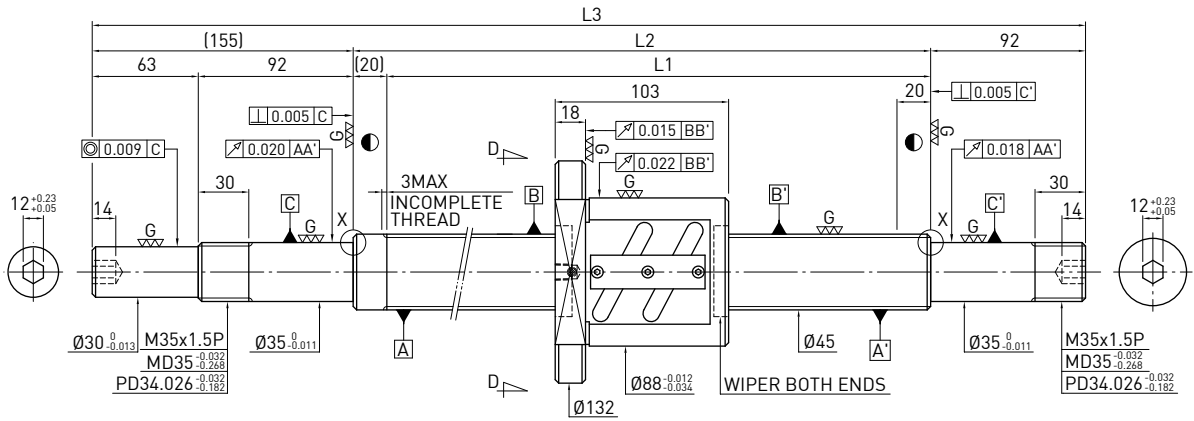

Ball screw Data	
Direction	Right Hand
Lead (mm)	10
Lead Angle	3.92°
P.C.D (mm)	46.4
Screw P.C.D (mm)	46.4
RD (mm)	39.91
Steel Ball (mm)	Ø6.35
Circuits	2.5x1
Dynamic Load C (Kgf)	3115
Static Load Co (Kgf)	7952
Axial Play (mm)	0
Drag Torque (Kgf-cm)	4.58~9.5
Spacer Ball	-

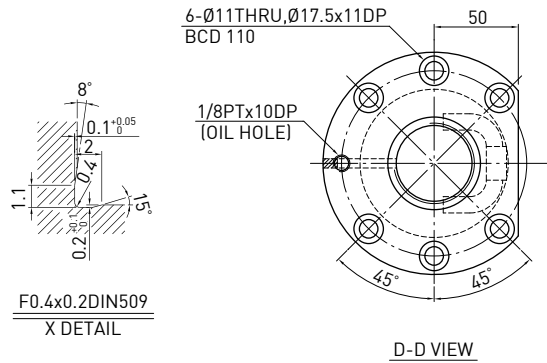

Unit : mm

Stroke	HIWIN Code	L1	L2	L3	Accuracy grade
550	R45-10B1-OFSW-680-947-0.018	680	700	947	5
850	R45-10B1-OFSW-980-1247-0.018	980	1000	1247	5
1250	R45-10B1-OFSW-1380-1647-0.018	1380	1400	1647	5
1650	R45-10B1-OFSW-1780-2047-0.018	1780	1800	2047	5
2350	R45-10B1-OFSW-2480-2747-0.018	2480	2500	2747	5



**O F S W TYPE (SHAFT OD 50, LEAD 10)**

◀ Standard

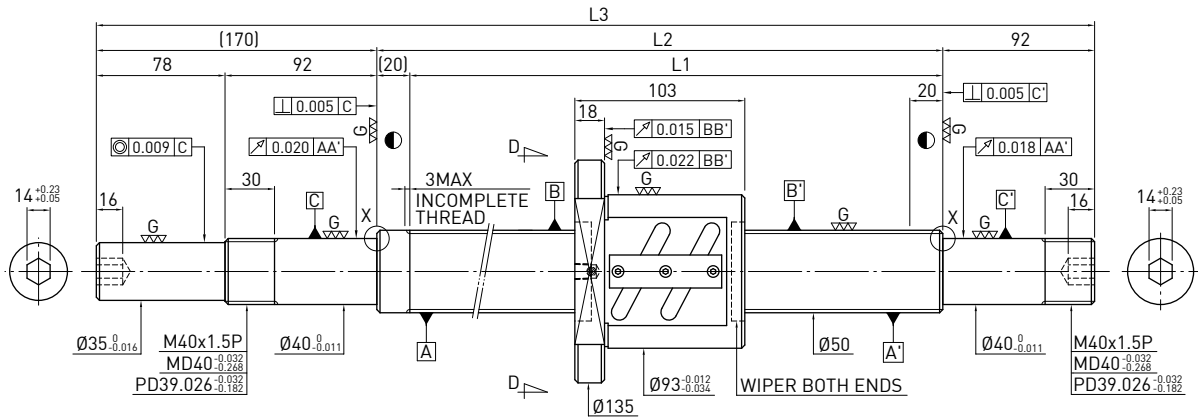

Ball screw Data	
Direction	Right Hand
Lead (mm)	10
Lead Angle	3.54°
P.C.D (mm)	51.4
Screw P.C.D (mm)	51.4
RD (mm)	44.91
Steel Ball (mm)	Ø6.35
Circuits	2.5x1
Dynamic Load C (Kgf)	3263
Static Load Co (Kgf)	8835
Axial Play (mm)	0
Drag Torque (Kgf-cm)	4.84~11.28
Spacer Ball	-

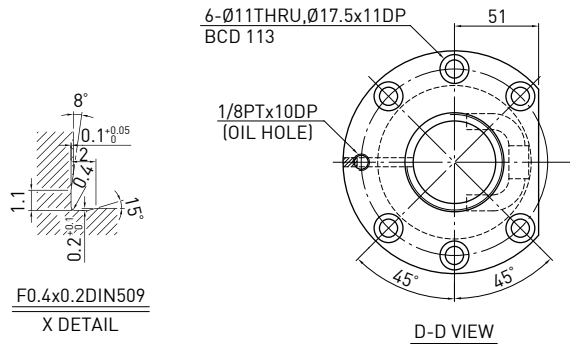

Unit : mm

Stroke	HIWIN Code	L1	L2	L3	Accuracy grade
450	R50-10B1-OFSW-580-862-0.018	580	600	862	5
650	R50-10B1-OFSW-780-1062-0.018	780	800	1062	5
850	R50-10B1-OFSW-980-1262-0.018	980	1000	1262	5
1050	R50-10B1-OFSW-1180-1462-0.018	1180	1200	1462	5
1350	R50-10B1-OFSW-1480-1762-0.018	1480	1500	1762	5
1850	R50-10B1-OFSW-1980-2262-0.018	1980	2000	2262	5
2450	R50-10B1-OFSW-2580-2862-0.018	2580	2600	2862	5

**O F S W** TYPE (SHAFT OD 50, LEAD 10)

◀ Standard

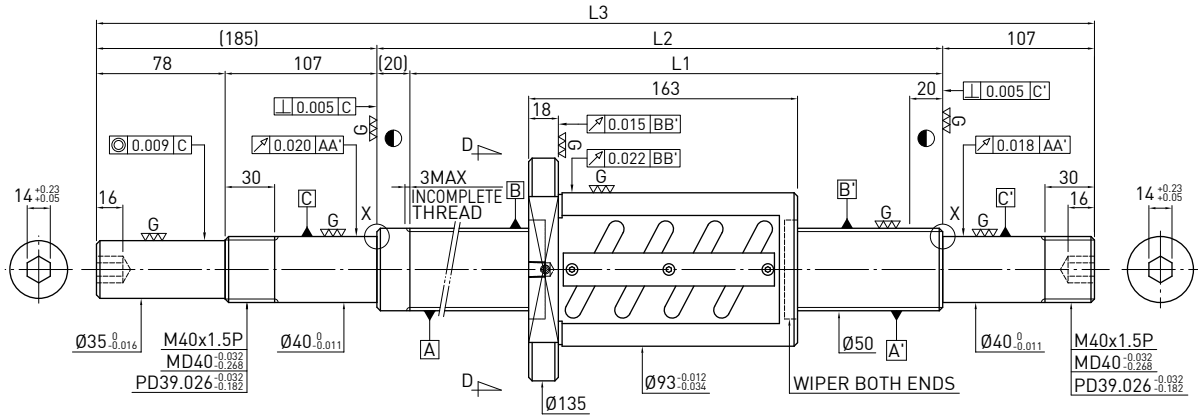

Ball screw Data	
Direction	Right Hand
Lead (mm)	10
Lead Angle	3.54°
P.C.D (mm)	51.4
Screw P.C.D (mm)	51.4
RD (mm)	44.91
Steel Ball (mm)	Ø6.35
Circuits	2.5x2
Dynamic Load C (Kgf)	5923
Static Load Co (Kgf)	17670
Axial Play (mm)	0
Drag Torque (Kgf-cm)	10.48-17.48
Spacer Ball	-

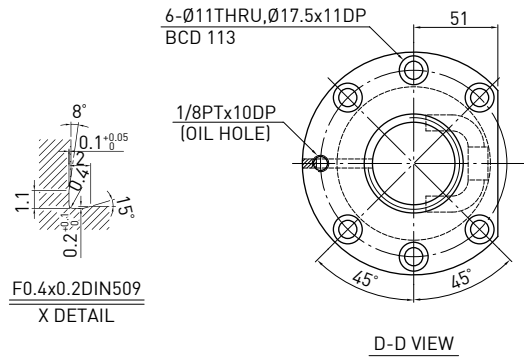

Unit : mm

Stroke	HIWIN Code	L1	L2	L3	Accuracy grade
350	R50-10B2-0FSW-580-892-0.018	580	600	892	5
550	R50-10B2-0FSW-780-1092-0.018	780	800	1092	5
750	R50-10B2-0FSW-980-1292-0.018	980	1000	1292	5
950	R50-10B2-0FSW-1180-1492-0.018	1180	1200	1492	5
1250	R50-10B2-0FSW-1480-1792-0.018	1480	1500	1792	5
1750	R50-10B2-0FSW-1980-2292-0.018	1980	2000	2292	5
2350	R50-10B2-0FSW-2580-2892-0.018	2580	2600	2892	5

## 6.5 High Lead Ground Ballscrew

**D F S H TYPE** (SHAFT OD 15, LEAD 10)

◀ High Lead

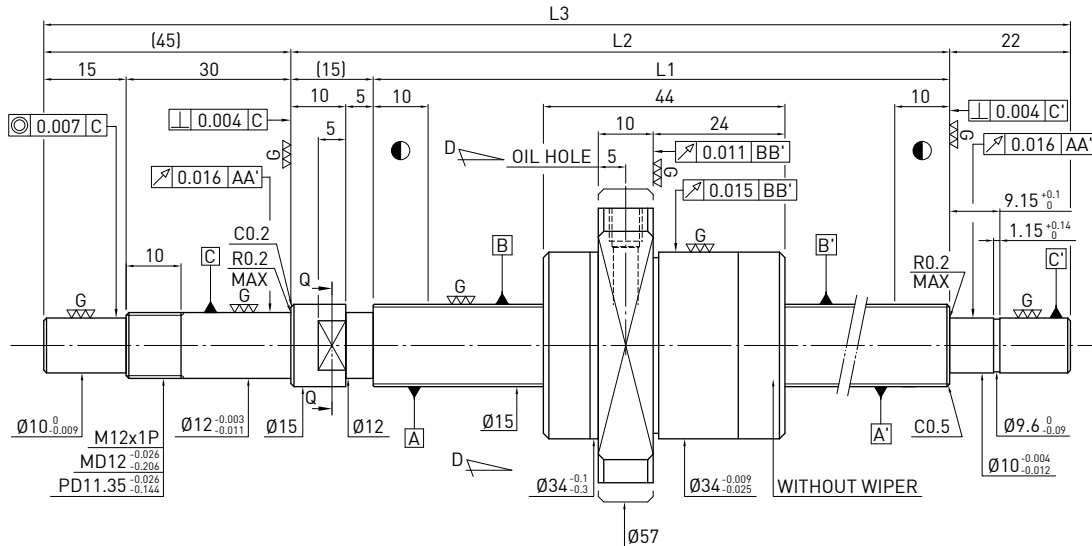

Ballscrew Data		
Direction	Right Hand	
Lead (mm)	10	
Lead Angle	11.53°	
P.C.D (mm)	15.6	
Screw P.C.D (mm)	15.6	
RD (mm)	12.324	
Steel Ball (mm)	Ø3.175	
Circuits	2.8x2	
Dynamic Load C (Kgf)	940	1490
Static Load Co (Kgf)	1590	3190
Axial Play (mm)	0	0.005 or less
Drag Torque (Kgf-cm)	0.2~1	-
Spacer Ball	1 : 1	-

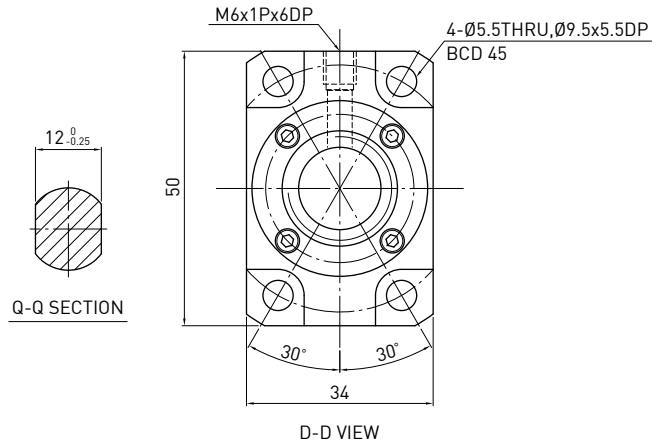

Unit : mm

Stroke	HIWIN Code	L1	L2	L3	Accuracy grade
150	2R15-10U2-DFSH-239-321-0.018	239	254	321	5
200	2R15-10U2-DFSH-289-371-0.018	289	304	371	5
250	2R15-10U2-DFSH-339-421-0.018	339	354	421	5
300	2R15-10U2-DFSH-389-471-0.018	389	404	471	5
350	2R15-10U2-DFSH-439-521-0.018	439	454	521	5
400	2R15-10U2-DFSH-489-571-0.018	489	504	571	5
450	2R15-10U2-DFSH-539-621-0.018	539	554	621	5
500	2R15-10U2-DFSH-589-671-0.018	589	604	671	5
550	2R15-10U2-DFSH-639-721-0.018	639	654	721	5
600	2R15-10U2-DFSH-689-771-0.018	689	704	771	5
700	2R15-10U2-DFSH-789-871-0.018	789	804	871	5
800	2R15-10U2-D FSH-889-971-0.018	889	904	971	5

**D F S H TYPE (SHAFT OD 15, LEAD 20)**

◀ High Lead

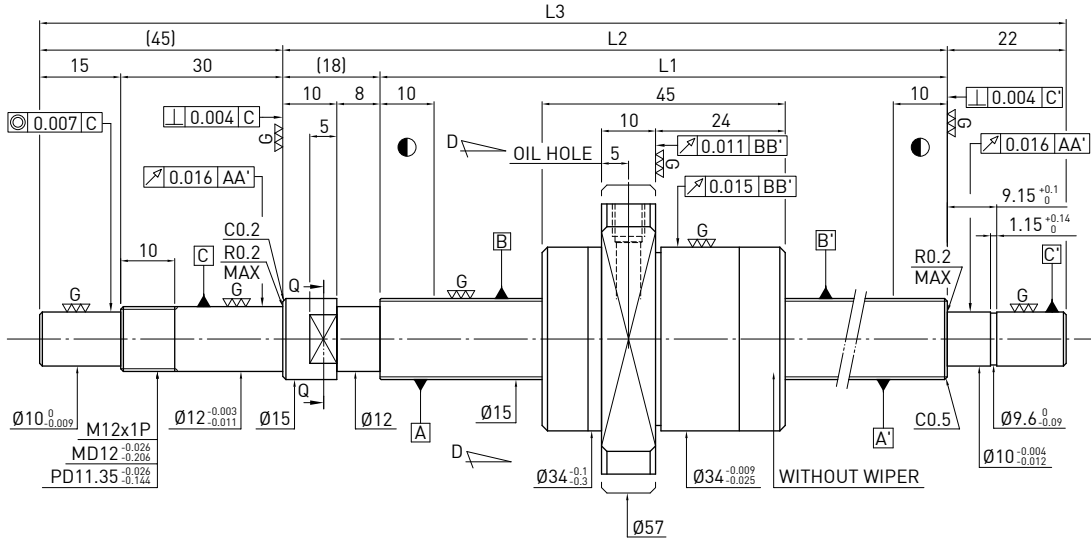

Ball screw Data	
Direction	Right Hand
Lead (mm)	20
Lead Angle	22.2°
P.C.D (mm)	15.6
Screw P.C.D (mm)	15.6
RD (mm)	12.324
Steel Ball (mm)	$\varnothing 3.175$
Circuits	1.8x2
Dynamic Load C (Kgf)	620      990
Static Load Co (Kgf)	1030      2070
Axial Play (mm)	0      0.005 or less
Drag Torque (Kgf-cm)	0.2-0.9      -
Spacer Ball	1 : 1      -

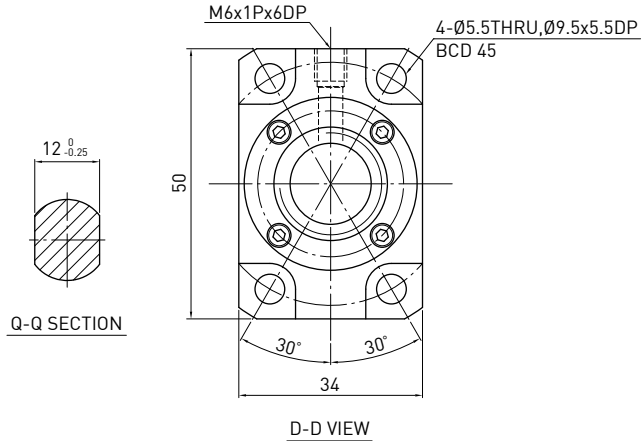

Unit : mm

Stroke	HIWIN Code	L1	L2	L3	Accuracy grade
150	2R15-20S2-DFSH-236-321-0.018	236	254	321	5
200	2R15-20S2-DFSH-286-371-0.018	286	304	371	5
250	2R15-20S2-DFSH-336-421-0.018	336	354	421	5
300	2R15-20S2-DFSH-386-471-0.018	386	404	471	5
350	2R15-20S2-DFSH-436-521-0.018	436	454	521	5
400	2R15-20S2-DFSH-486-571-0.018	486	504	571	5
450	2R15-20S2-DFSH-536-621-0.018	536	554	621	5
500	2R15-20S2-DFSH-586-671-0.018	586	604	671	5
550	2R15-20S2-DFSH-636-721-0.018	636	654	721	5
600	2R15-20S2-DFSH-686-771-0.018	686	704	771	5
700	2R15-20S2-DFSH-786-871-0.018	786	804	871	5
800	2R15-20S2-DFSH-886-971-0.018	886	904	971	5

**F S H TYPE (SHAFT OD 15, LEAD 20)**

◀ High Lead

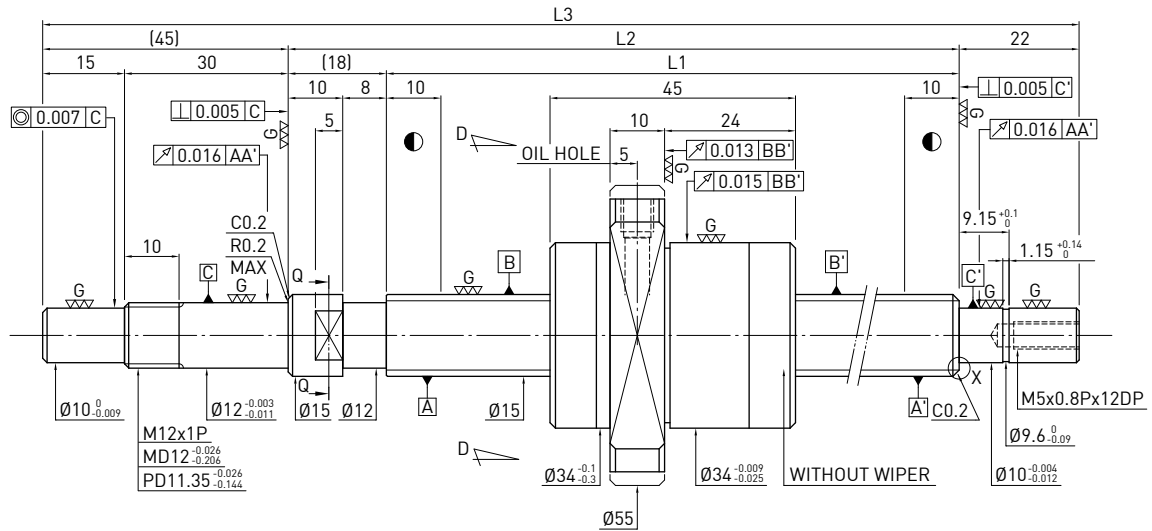

Ballscrew Data	
Direction	Right Hand
Lead (mm)	20
Lead Angle	22.2°
P.C.D (mm)	15.6
Screw P.C.D (mm)	15.6
RD (mm)	12.324
Steel Ball (mm)	Ø3.175
Circuits	1.8x1
Dynamic Load C (Kgf)	340      540
Static Load Co (Kgf)	510      1030
Axial Play (mm)	0      0.005 or less
Drag Torque (Kgf-cm)	0.15-0.8      -0.24
Spacer Ball	1 : 1      -

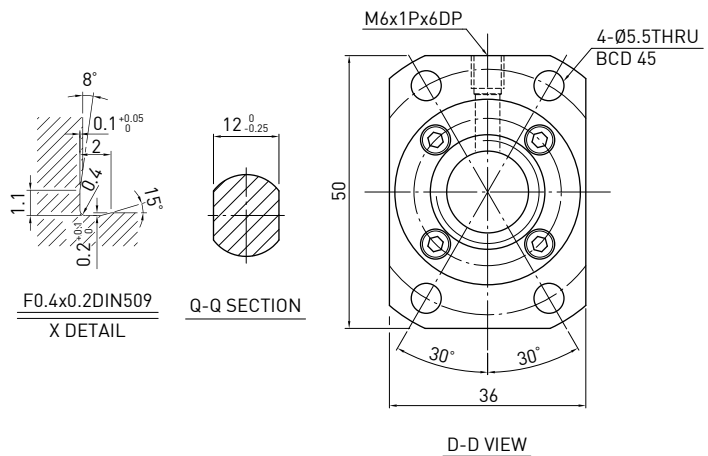

Unit : mm

Stroke	HIWIN Code	L1	L2	L3	Accuracy grade
100	R15-20S1-FSH-186-271-0.018	186	204	271	5
150	R15-20S1-FSH-236-321-0.018	236	254	321	5
200	R15-20S1-FSH-286-371-0.018	286	304	371	5
250	R15-20S1-FSH-336-421-0.018	336	354	421	5
300	R15-20S1-FSH-386-471-0.018	386	404	471	5
350	R15-20S1-FSH-436-521-0.018	436	454	521	5
400	R15-20S1-FSH-486-571-0.018	486	504	571	5
450	R15-20S1-FSH-536-621-0.018	536	554	621	5
500	R15-20S1-FSH-586-671-0.018	586	604	671	5
550	R15-20S1-FSH-636-721-0.018	636	654	721	5
600	R15-20S1-FSH-686-771-0.018	686	704	771	5
700	R15-20S1-FSH-786-871-0.018	786	804	871	5
800	R15-20S1-FSH-886-971-0.018	886	904	971	5
1000	R15-20S1-FSH-1086-1171-0.018	1086	1104	1171	5

**D F S H** TYPE (SHAFT OD 16, LEAD 16)

◀ High Lead

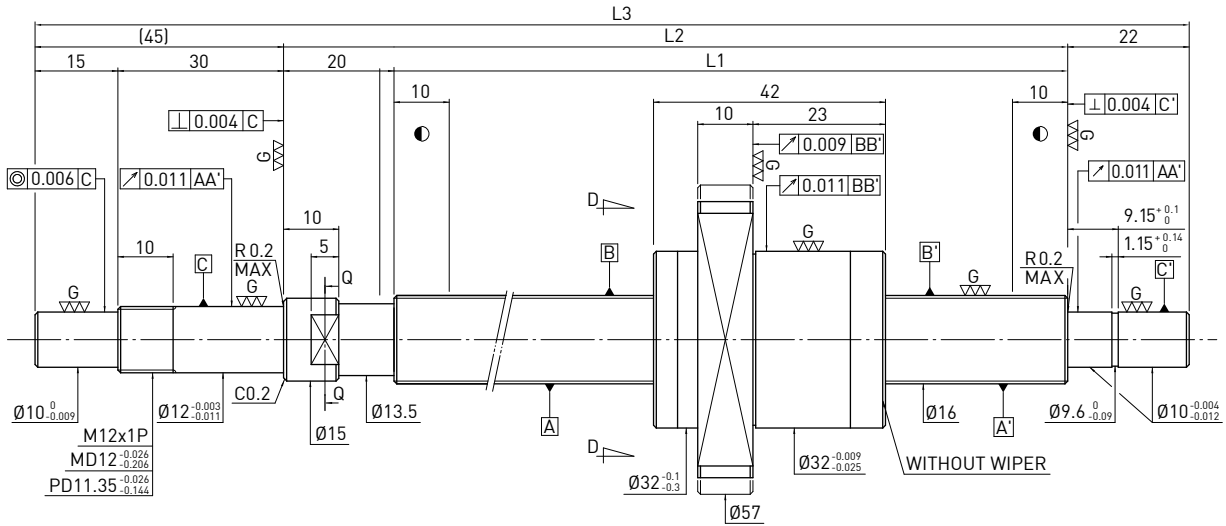

Ball screw Data	
Direction	Right Hand
Lead (mm)	16
Lead Angle	17.06°
P.C.D (mm)	16.6
Screw P.C.D (mm)	16.6
RD (mm)	13.324
Steel Ball (mm)	$\varnothing 3.175$
Circuits	1.8x2
Dynamic Load C (Kgf)	670      1060
Static Load Co (Kgf)	1140      2280
Axial Play (mm)	0      0.005 or less
Drag Torque (Kgf-cm)	0.2-1      -
Spacer Ball	1 : 1      -

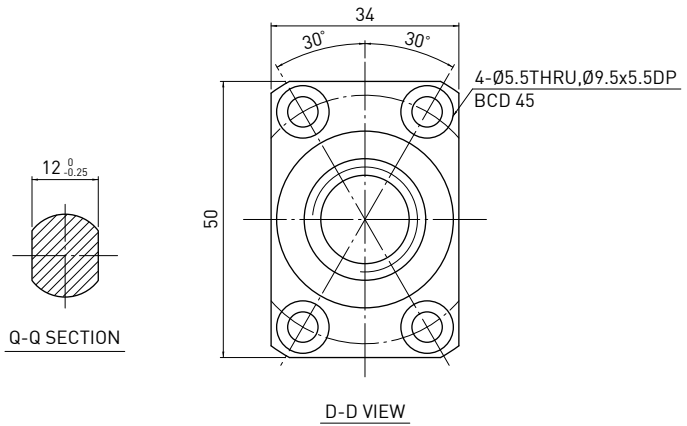

Unit : mm

Stroke	HIWIN Code	L1	L2	L3	Accuracy grade
150	2R16-16S2-DFSH-234-321-0.018	234	254	321	5
200	2R16-16S2-DFSH-284-371-0.018	284	304	371	5
250	2R16-16S2-DFSH-334-421-0.018	334	354	421	5
300	2R16-16S2-DFSH-384-471-0.018	384	404	471	5
350	2R16-16S2-DFSH-434-521-0.018	434	454	521	5
400	2R16-16S2-DFSH-484-571-0.018	484	504	571	5
450	2R16-16S2-DFSH-534-621-0.018	534	554	621	5
500	2R16-16S2-DFSH-584-671-0.018	584	604	671	5
550	2R16-16S2-DFSH-634-721-0.018	634	654	721	5
600	2R16-16S2-DFSH-684-771-0.018	684	704	771	5
700	2R16-16S2-DFSH-784-871-0.018	784	804	871	5
800	2R16-16S2-DFSH-884-971-0.018	884	904	971	5



**D F S H** TYPE (SHAFT OD 25, LEAD 20)

◀ High Lead

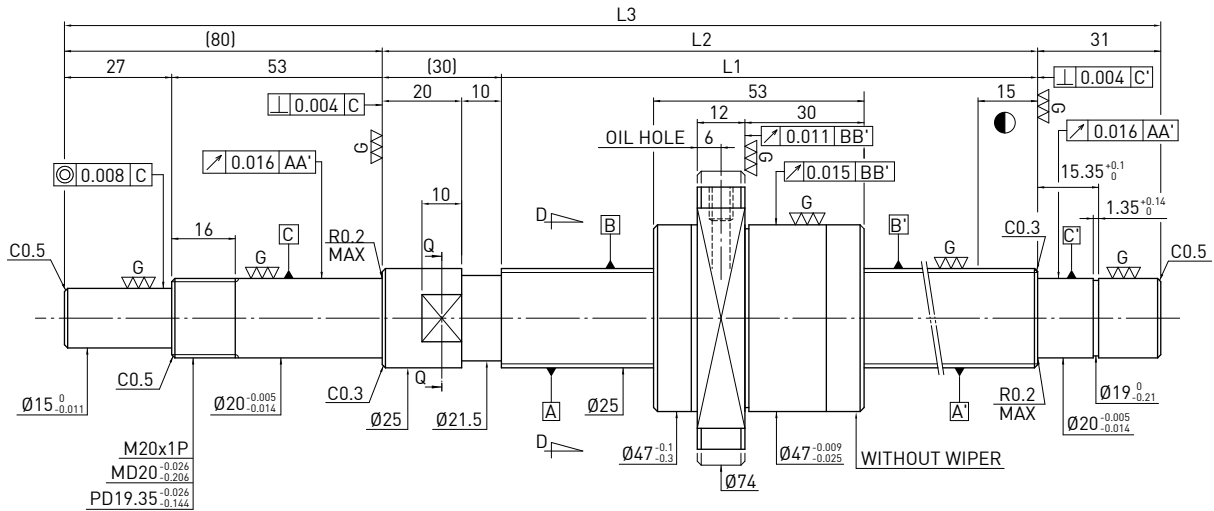

Ballscrew Data	
Direction	Right Hand
Lead (mm)	20
Lead Angle	13.76°
P.C.D (mm)	26
Screw P.C.D (mm)	26
RD (mm)	21.132
Steel Ball (mm)	Ø4.763
Circuits	1.8x2
Dynamic Load C (Kgf)	1410      2240
Static Load Co (Kgf)	2620      5230
Axial Play (mm)	0      0.005 or less
Drag Torque (Kgf-cm)	0.2-1      -
Spacer Ball	1 : 1      -

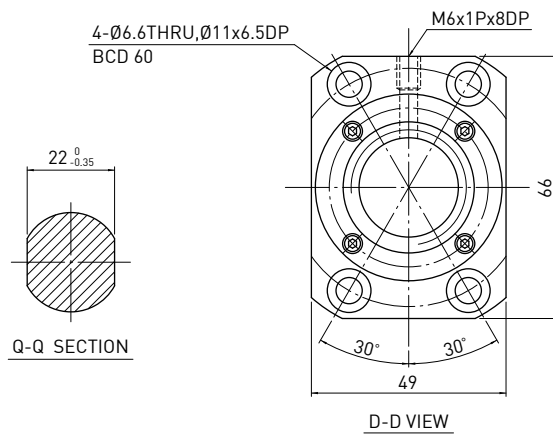

Unit : mm

Stroke	HIWIN Code	L1	L2	L3	Accuracy grade
500	2R25-20S2-DFSH-610-751-0.018	610	640	751	5
600	2R25-20S2-DFSH-710-851-0.018	710	740	851	5
800	2R25-20S2-DFSH-910-1051-0.018	910	940	1051	5
1000	2R25-20S2-DFSH-1110-1251-0.018	1110	1140	1251	5
1200	2R25-20S2-DFSH-1310-1451-0.018	1310	1340	1451	5
1400	2R25-20S2-DFSH-1510-1651-0.018	1510	1540	1651	5
1600	2R25-20S2-DFSH-1710-1851-0.018	1710	1740	1851	5



## 6.6 Ultra High Lead Ground Ballscrew

**D F S H TYPE** (SHAFT OD 16, LEAD 32)

◀ Ultra High Lead

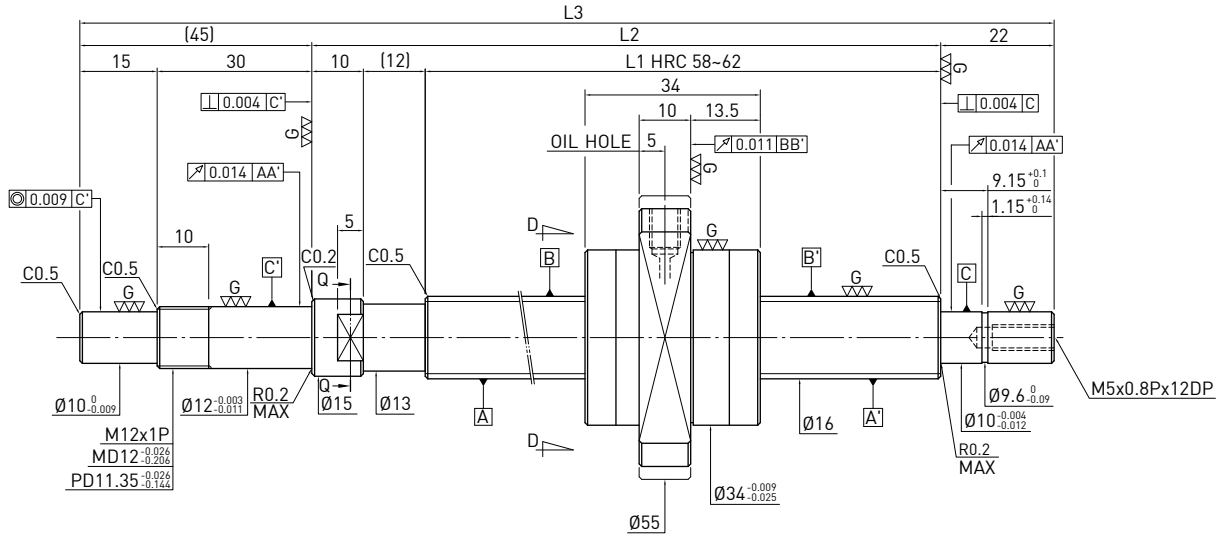

Ball screw Data	
Direction	Right Hand
Lead (mm)	32
Lead Angle	31.53°
P.C.D (mm)	16.6
Screw P.C.D (mm)	16.6
RD (mm)	13.324
Steel Ball (mm)	Ø3.175
Circuits	0.8x2
Dynamic Load C (Kgf)	490
Static Load Co (Kgf)	1010
Axial Play (mm)	0      0.005 MAX
Drag Torque (Kgf-cm)	0.15-1.0      0.24 MAX
Spacer Ball	1 : 1      -

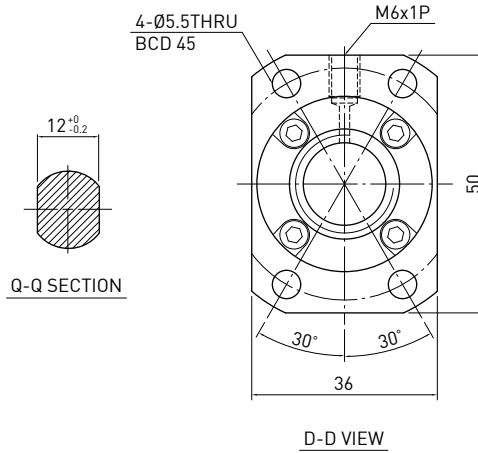

Unit : mm

Stroke	HIWIN Code	L1	L2	L3	Accuracy grade
300	2R16-32V2-DFSH-382-471-0.018	382	404	471	5
500	2R16-32V2-DFSH-582-671-0.018	582	604	671	5
800	2R16-32V2-DFSH-882-971-0.018	882	904	971	5
1200	2R16-32V2-DFSH-1282-1371-0.018	1282	1304	1371	5

**D F S H**

**TYPE (SHAFT OD 20, LEAD 40)**

◀ Ultra High Lead

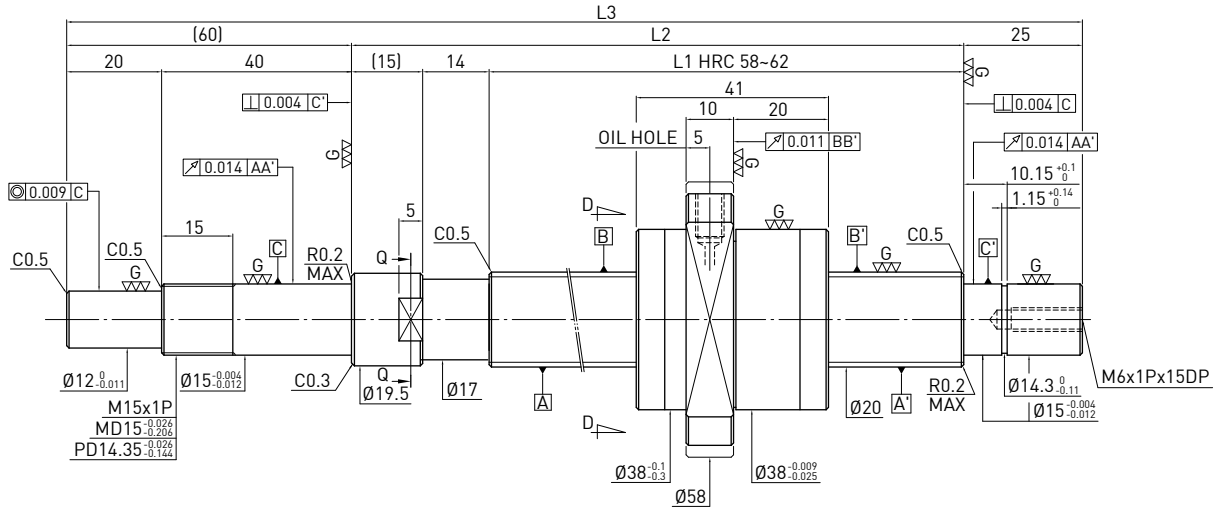

Ballscrew Data	
Direction	Right Hand
Lead (mm)	40
Lead Angle	31.47°
P.C.D (mm)	20.8
Screw P.C.D (mm)	20.8
RD (mm)	17.324
Steel Ball (mm)	Ø3.175
Circuits	0.8x2
Dynamic Load C (Kgf)	540
Static Load Co (Kgf)	1240
Axial Play (mm)	0      0.005 MAX
Drag Torque (Kgf-cm)	0.2-1.2      0.3 MAX
Spacer Ball	-      -

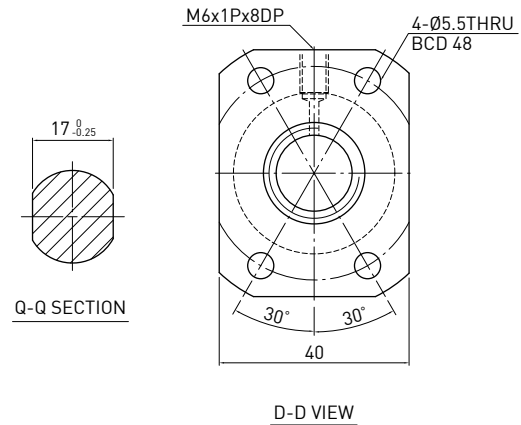

Unit : mm

Stroke	HIWIN Code	L1	L2	L3	Accuracy grade
400	2R20-40V2-DFSH-506- 620-0.018	506	535	620	5
600	2R20-40V2-DFSH-706- 820-0.018	706	735	820	5
800	2R20-40V2-DFSH-906- 1020-0.018	906	935	1020	5
1000	2R20-40V2-DFSH-1106- 1220-0.018	1106	1135	1220	5
1200	2R20-40V2-DFSH-1306- 1420-0.018	1306	1335	1420	5
1600	2R20-40V2-DFSH-1706- 1820-0.018	1706	1735	1820	5

**D F S H TYPE (SHAFT OD 25, LEAD 50)**

◀ Ultra High Lead

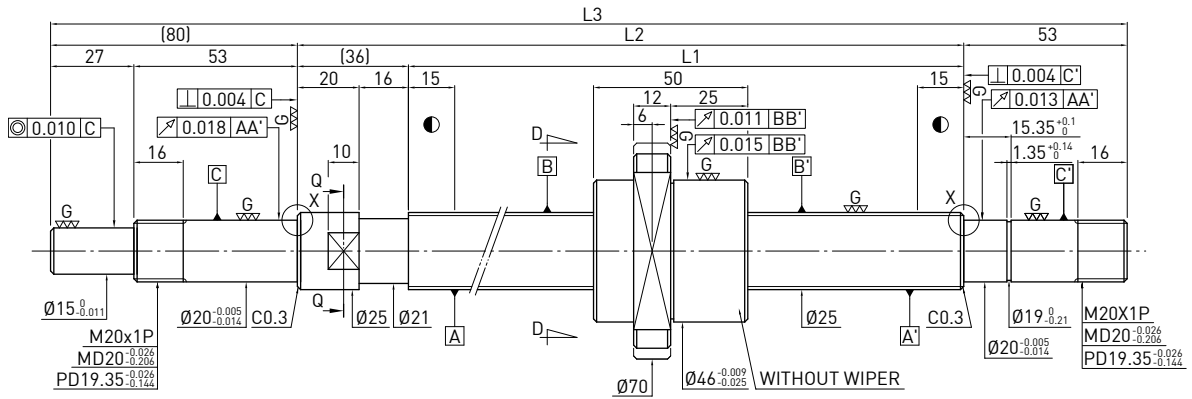

Ball screw Data	
Direction	Right Hand
Lead (mm)	50
Lead Angle	31.67°
P.C.D (mm)	25.8
Screw P.C.D (mm)	25.8
RD (mm)	21.744
Steel Ball (mm)	Ø3.969
Circuits	0.8x2
Dynamic Load C (Kgf)	800
Static Load Co (Kgf)	1930
Axial Play (mm)	0      0.005 or less
Drag Torque (Kgf-cm)	0.3~2.19      ~0.5
Spacer Ball	1 : 1      -

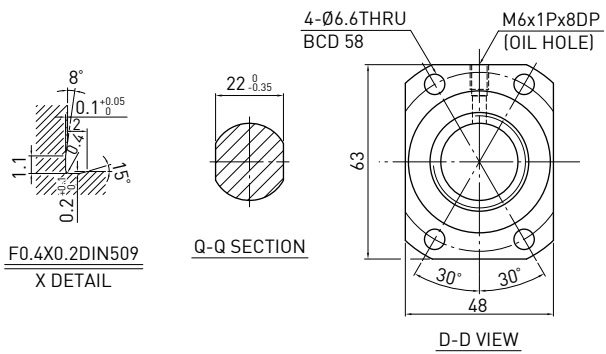

Unit : mm

Stroke	HIWIN Code	L1	L2	L3	Accuracy grade
700	2R25-50V2-DFSH-844-1013-0.018	844	880	1013	5
1000	2R25-50V2-DFSH-1144-1313-0.018	1144	1180	1313	5
1500	2R25-50V2-DFSH-1644-1813-0.018	1644	1680	1813	5
2000	2R25-50V2-DFSH-2144-2313-0.018	2144	2180	2313	5

# 7 Rolled Ballscrews

## 7.1 Introduction

HIWIN Rolled Ballscrews are made by the rolling process of the screw spindle instead of the grinding process. Rolled ballscrews not only have the benefit of low friction and smooth running for the linear feed system compared with traditional screws, but also can be supplied by quick stock delivery and lower production price.

HIWIN uses the most advanced technology in the ballscrew rolling process. By maintaining the homogeneous manufacturing procedure of selecting materials, rolling, heat treating, machining and assembling.

In general, rolled ballscrews use the same preload method as the precision ground ballscrews, except that there are some differences in the lead error definition and the geometric tolerance. The grade of the rolled ballscrews can be ordered according to the same nut dimension of the precision ground ballscrew. If the ends of the spindle are unmachined, the geometric tolerance does not apply. The production scale of each type of the ballscrews and the accuracy classification are described in the following sections (the unit of length used is in mm).

## 7.2 Precision Rolled Ballscrews

Table 7.1 gives the lead accuracy of the precision rolled ballscrews. The lead accuracy is measured by the accumulated lead error of any portion of 300 mm in length. The maximum axial plays of the precision rolled ballscrews are shown in Table 7.2. These ballscrews can be preloaded as the precision ground ones. The categories of the precision rolled ballscrews are listed in Table 7.3.

Fig. 7.1 show the geometric tolerance of the general rolled ballscrews. has a variety of the precision rolled ballscrews for our customers' urgent requirement.

Table 7.1 Accuracy grade of precision rolled ballscrew Unit : 0.00mm

Cumulative	C6	C7	C8	C10
$v_{300}$	23	50	100	210
$e_p$	$e_p = \frac{\text{length measured}}{300} \times v_{300}$			

Cumulative $v_{300}$ length measured	C6	C7	C8	C10
	0~100	18	44	84
101~200	20	48	92	194
201~315	23	50	100	210

Measuring length unit: mm

Table 7.2 Maximum axial play of precision rolled ballscrew Unit : mm

Ball diameter	≤ 2	2.381 3.175	3.969	4.763	6.35	7.144	7.938	9.525
Axial play	0.06	0.07	0.10	0.12	0.15	0.16	0.17	0.18

Table 7.3 Category of HIWIN precision rolled ballscrew

Unit : mm

Nominal diameter do (mm)	Lead																		Max.screw length			
	1	1.25	2	2.5	3	4	5	5.08	6	8	10	12	16	20	25	30	32	36		40	50	63
6	●	●																				800
8	●		●	■	●		●															800
10			●	■	●	●	●		●		●											1000
12			●	■	●	■	●	●		●	●	●										1200
14					●	●	●				●											2000
15											●			●								2000
16	●		■	■		●	■	●	●	●	■	●	●				●					3000
18										●												3000
20				■		●	■	■	●	●	●						■			●		3000
22							●				●											3000
25				●		●	■	■	●	●	■					●						4000
28							●		●													4000
32						■	■	■	●	●	■					●		●		●		4500
36							●		●	●	●	●			●			●				4500
38											■		●	●						●		5600
40							■		●	●	■	●	●	●	●				●		●	5600
45											●	●			●							5600
48											●				●							5600
50							●		●		■	●	●	●		●				●	●	5600
55									●		●											5600
63											■	●	●	■						●		5600
80											●		●	●		●						6500

■ : Right turn and left turn    ● : Right turn only. Please contact Hiwin for special request

Note: The maximum length for ballscrew is based on grade C7. For rolled ballscrew, the maximum length varies according to lead accuracy grade.

### 7.3 General Type of Rolled Ballscrews

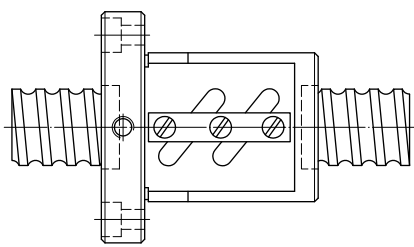
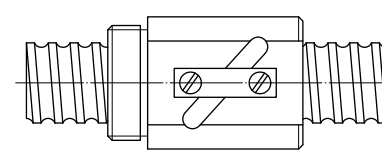
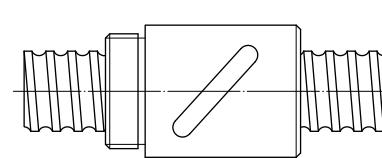
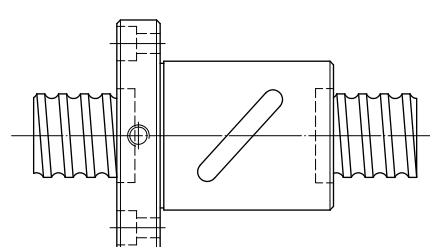
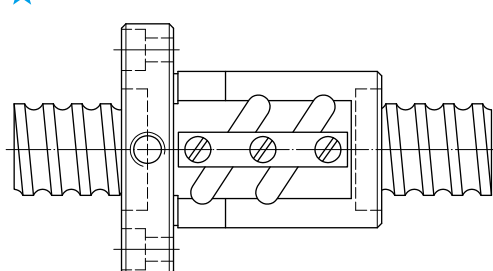
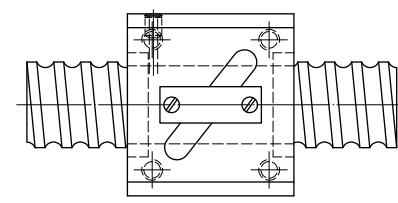
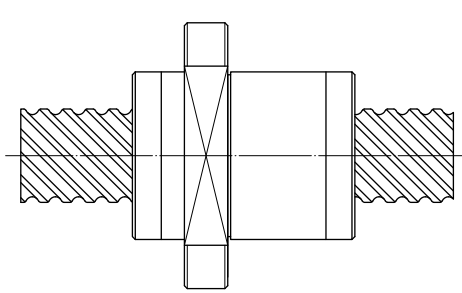
page	General Type		page
139	<p>★★ <b>FSW</b></p>  <p>Flange end, single nut, tube within the nut diameter</p>	<p><b>RSV</b></p>  <p>Round, single nut, tube above the nut diameter</p>	140
141	<p><b>RSB</b></p>  <p>Round, single nut, bonded return tube</p>	<p>★★ <b>FSB</b></p>  <p>Flange end, single nut, bonded return tube</p>	142
143	<p>★★ <b>FSV</b></p>  <p>Flange end, single nut, tube above the nut diameter</p>	<p><b>SSV</b></p>  <p>Square, single nut, tube above the nut diameter</p>	144
page	High Lead Type		page
145	<p>★★ <b>FSH</b></p>  <p>Large lead, flange mounted, single nut, end cap</p>		145

\*Different design required by the drawing approval, please contact with HIWIN engineers for the other type listed above.

\*Double asterisks(★★): Self-Lubricating Ballscrew E2 design is available, except the shaft diameter under 16mm or ball diameter under 2.381mm.

## 7.4 Dimensions for Rolled Ballscrews

### F S W TYPE

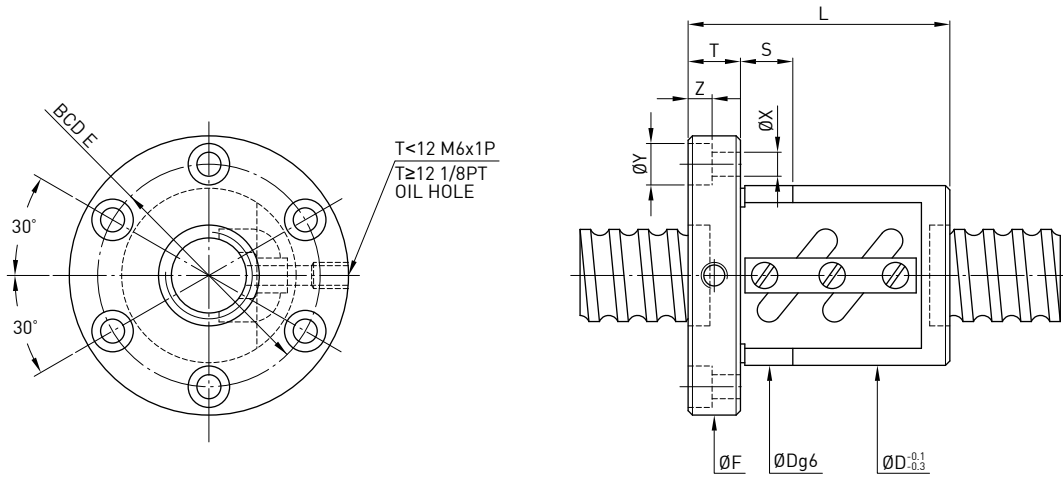

Model	Size		Ball Dia.	Circuits	Dynamic Load 1x10 <sup>6</sup> revs C ( kgf )	Static Load Co ( kgf )	Nut		Flange							Fit
	Nominal Dia.	Lead					L	D	F	BCD-E	T	Bolt				
												X	Y	Z	S	
8-2.5B1	8	2.5	2.000	2.5x1	218	317	34	26	47	35	8	5.5	9.5	5.5	8	
10-2.5B1	10			2.5x1	252	405	34	28	52	38	8	5.5	9.5	5.5	8	
10-4B1	12	4	2.381	2.5x1	304	466	41	30	53	41	10	5.5	9.5	5.5	10	
12-4B1				2.5x1	344	574	41	30	50	40	10	5.5	9.5	5.5	12	
16-5B1	16	5	3.175	2.5x1	679	1226	43	40	64	51	10	5.5	9.5	5.5	12	
20-5C1	20			3.5x1	1001	2149	50	44	68	55	12	5.5	9.5	5.5	12	
25-5B2	25			2.5x2	1534	3975	60	50	74	62	12	5.5	9.5	5.5	12	
25-10B1		10	2.5x1	1459	2983	65	60	86	73	16	6.6	11	6.5	12		
32-5B2	32	5	3.175	2.5x2	1702	5098	60	58	84	71	12	6.6	11	6.5	12	
32-10B2				10	2.5x2	4379	10345	98	74	108	90	16	9	14	8.5	15
40-10B2	40	10	6.350	2.5x2	4812	12732	102	84	125	104	18	11	17.5	11	15	
50-10C2	50			3.5x2	7146	22477	126	94	135	114	18	11	17.5	11	20	
63-10C2	63			3.5x2	7869	28290	128	110	152	130	20	11	17.5	11	20	

**R S V TYPE**

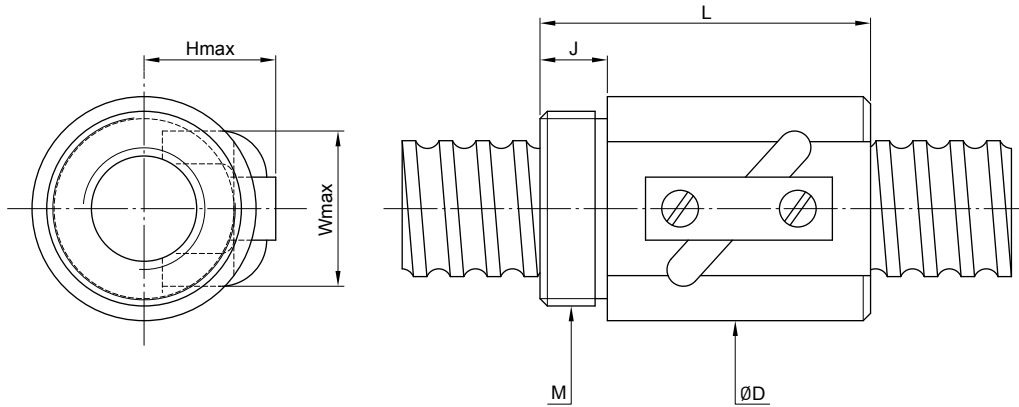

Model	Size		Ball Dia.	Circuits	Dynamic Load 1x10 <sup>6</sup> revs C [ kgf ]	Static Load Co [ kgf ]	Nut		Mounting Thread M	Mounting Thread Length J	Return Tube Width W	Return Tube Height H
	Nominal Dia.	Lead					L	D				
8-2.5B1	8	2.5	2.000	2.5x1	218	317	28	18	M18x1P	10	15	15
10-2.5B1	10			2.5x1	252	405	30	20	M18x1P	10	17	17
10-4B1	12	4	2.381	2.5x1	305	466	32	23	M22x1P	10	20	20
12-4B1				2.5x1	344	574	32	25	M24x1P	10	22	21
16-5B1	16	5	3.175	2.5x1	679	1226	40	31	M28x1.5P	10	23	25
16-5.08B1		5.08		2.5x1	763	1399	45	30	M25x1.5P	13	24	21
16-5.08C1	16		3.5x1	1013	1945	45	30	M25x1.5P	13	24	21	
20-5C1	20	5	3.175	3.5x1	1001	2149	45	35	M32x1.5P	12	27	22
25-5B2	25			2.5x2	1534	3975	58	40	M38x1.5P	16	31	25
25-10B2		10	4.763	2.5x2	2663	6123	94	45	M38x1.5P	16	38	32
32-5B2	32	5	3.175	2.5x2	1702	5098	60	54	M50x2P	18	38	29
32-10B2				2.5x2	4379	10345	95	58	M52x2P	18	44	36
40-10B2	40	10	6.350	2.5x1	4812	12732	102	65	M60x2P	25	52	41
50-10C2	50			3.5x2	7146	22477	130	80	M75x2P	30	62	46
63-10C2	63	12	7.938	3.5x2	7869	28290	132	95	M90x2P	40	74	52
63-12C3				3.5x3	16828	58535	205	102	M95x3P	35	75	59



**R S B TYPE**

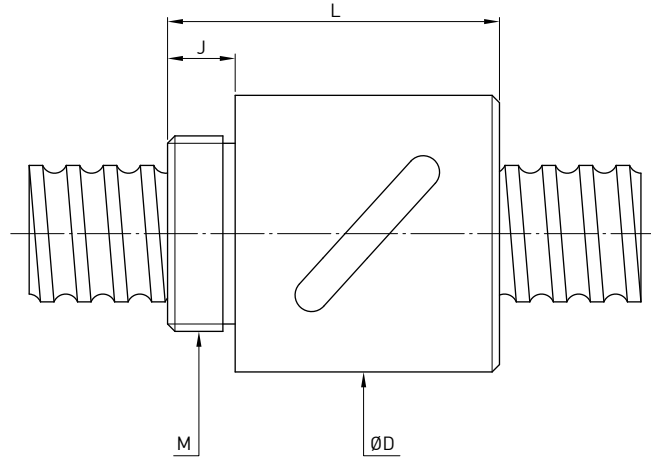

Model	Size		Ball Dia.	Circuits	Dynamic Load 1x10 <sup>6</sup> revs C ( kgf )	Static Load Co ( kgf )	Nut		Mounting Thread	Mounting Thread Length
	Nominal Dia.	Lead					L	D		
8-2.5B1	8	2.5	2.000	2.5x1	218	317	24	22	M18x1P	7.5
10-2.5B1	10			2.5x1	252	405	24	24	M20x1P	7.5
10-4B1	12	4	2.381	2.5x1	304	466	34	26	M22x1P	10
12-4B1				2.5x1	344	574	34	28	M25x1.5P	10
16-5B1	16	5	3.175	2.5x1	679	1226	42	36	M30x1.5P	12
20-5C1	20			3.5x1	1001	2149	54	40	M36x1.5P	14
25-5B2	25	5	3.175	2.5x2	1534	3975	69	46	M42x1.5P	19
32-5B2	32			2.5x2	1702	5098	69	54	M50x2P	19
32-10B2	40	10	6.350	2.5x2	4379	10345	105	68	M62x2P	19
40-10B2				2.5x2	4812	12732	110	76	M70x2P	24
50-10C2				3.5x2	7146	22477	135	88	M82x2P	29
63-10C2				3.5x2	7869	28290	135	104	M95x2P	29

**F S B TYPE**

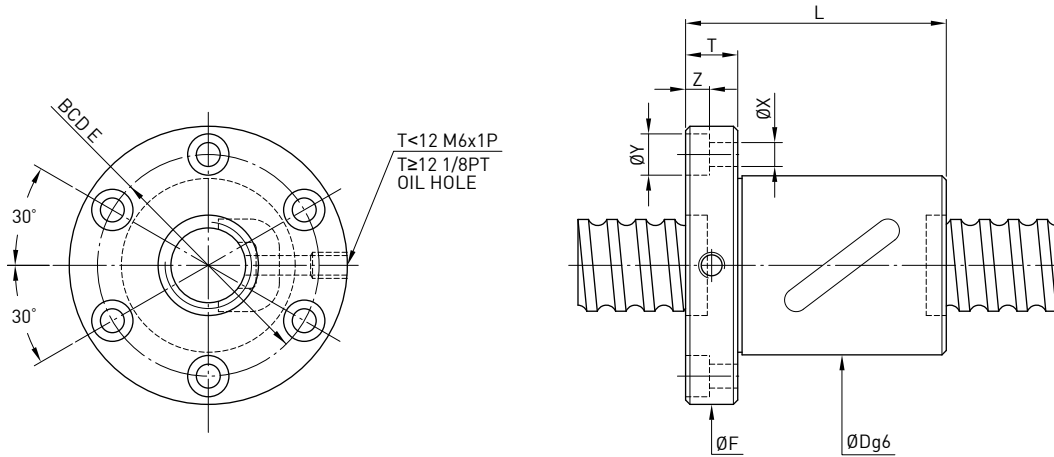

Model	Size		Ball Dia.	Circuits	Dynamic Load 1x10 <sup>6</sup> revs C ( kgf )	Static Load Co ( kgf )	Nut		Flange					
	Nominal Dia.	Lead					L	D	F	BCD-E	T	Bolt		
											X	Y	Z	
8-2.5B1	8	2.5	2.000	2.5x1	218	317	34	22	43	31	8	5.5	9.5	5.5
10-2.5B1	10			2.5x1	252	405	34	24	46	34	8	5.5	9.5	5.5
10-4B1	10	4	2.381	2.5x1	304	466	41	26	49	37	10	5.5	9.5	5.5
12-4B1				2.5x1	344	574	41	28	51	39	10	5.5	9.5	5.5
12-4C1	12	4	2.381	3.5x1	459	803	44	30	50	40	10	4.5	8	4.5
14-4C1	14			3.5x1	498	943	40	31	50	40	10	4.5	8	4.5
14-5B1	14	5	3.175	2.5x1	636	1095	40	32	50	40	10	4.5	8	4.5
16-4B1	16	4	2.381	2.5x1	390	744	41	35	56	43	10	5.5	9.5	5.5
16-5B1		5	3.175	2.5x1	679	1226	43	36	60	47	10	5.5	9.5	5.5
16-10B1	10	2.5x1		667	1194	52	36	60	47	12	6.6	11	6.5	
20-4C1	20	4	2.381	3.5x1	582	1329	40	40	60	50	10	4.5	8	4.5
20-5B1		2.5x1	745	1526	40	40	60	50	10	4.5	8	4.5		
20-5C1	20	5	3.175	3.5x1	1001	2149	50	40	64	51	12	5.5	9.5	5.5
25-5B1				2.5x1	845	1987	40	43	67	55	10	5.5	9.5	5.5
25-5B2	25	5	3.175	2.5x2	1534	3975	60	46	70	58	12	5.5	9.5	5.5
32-5B2	32			2.5x2	1702	5098	60	54	80	67	12	6.6	11	6.5
32-10B2	32	10	6.350	2.5x2	4379	10345	98	68	102	84	16	9	14	8.5
40-10B2				2.5x2	4812	12732	102	76	117	96	18	11	17.5	11
50-10C2	50	10	6.350	3.5x2	7146	22477	126	88	129	108	18	11	17.5	11
63-10C2	63			3.5x2	7869	28290	128	104	146	124	20	11	17.5	11

**F S V TYPE**

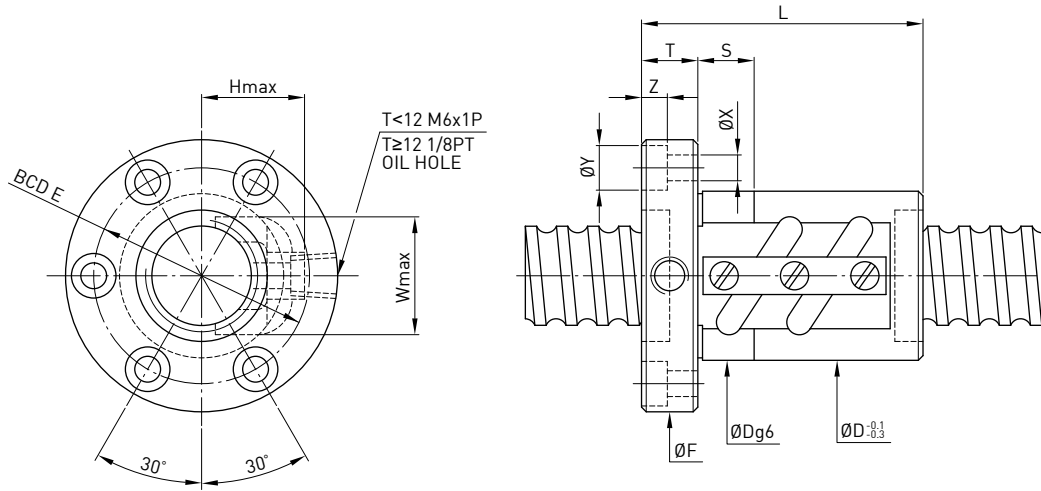

Model	Size		Ball Dia.	Circuits	Dynamic Load 1x10 <sup>6</sup> revs C ( kgf )	Static Load Co ( kgf )	Nut		Flange			Return Tube		Bolt			Fit
	Nominal Dia.	Lead					L	D	F	T	BCD-E	W	H	X	Y	Z	
8-2.5B1	8	2.5	2.000	2.5x1	218	317	34	18	41	8	29	15	15	5.5	9.5	5.5	8
10-2.5B1	10			2.5x1	252	405	34	20	43	8	31	17	17	5.5	9.5	5.5	8
10-4B1	10	4	2.381	2.5x1	304	466	41	23	46	10	34	20	20	5.5	9.5	5.5	10
12-4B1	12			2.5x1	344	574	41	25	48	10	36	22	21	5.5	9.5	5.5	12
16-5B1	16	5	3.175	2.5x1	679	1226	43	31	55	10	42	23	25	5.5	9.5	5.5	12
20-5C1	20			3.5x1	1001	2149	50	35	59	12	46	27	22	5.5	9.5	5.5	12
25-5B2	25	10	6.350	2.5x2	1534	3975	60	40	64	12	52	31	25	5.5	9.5	5.5	12
32-5B2	32			2.5x2	1702	5098	60	54	80	12	67	38	29	6.6	11	6.5	12
32-10B2	32	10	6.350	2.5x2	4379	10345	98	58	92	16	74	44	36	9	14	8.5	15
40-10B2	40			2.5x2	4812	12732	102	65	106	18	85	52	41	11	17.5	11	15
50-10C2	50	10	6.350	3.5x2	7146	22477	126	80	121	18	100	62	46	11	17.5	11	20
63-10C2	63			3.5x2	7869	28290	128	95	137	20	115	74	52	11	17.5	11	20

**S S V TYPE**

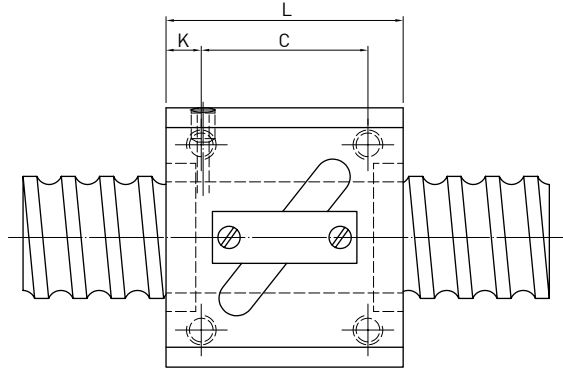
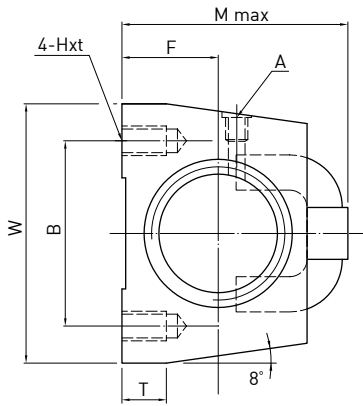

Model	Size		Ball Dia.	Circuits	Dynamic Load 1x10 <sup>6</sup> revs C ( kgf )	Static Load Co ( kgf )	W	F	H x t	L	B	C	K	T	A	M (max)
	Nominal Dia.	Lead														
14-4B1	14	4	2.381	2.5x1	376	682	34	13	M4x7	35	26	22	6	6	M6	30
14-4C1				3.5x1	498	943	34	13	M4x7	35	26	22	6	6	M6	30
14-5B1	16	5	3.175	2.5x1	636	1095	34	13	M4x7	35	26	22	6	6	M6	31
16-5B1				2.5x1	679	1226	42	16	M5x8	36	32	22	6	21.5	M6	36
20-5B1	20	10	4.763	2.5x1	745	1526	48	17	M6x10	35	35	22	5	9	M6	39
20-10B1				2.5x1	1280	2314	48	18	M6x10	58	35	35	10	9	M6	46
25-5B1	25	5	3.175	2.5x1	845	1987	60	20	M8x12	35	40	22	7	9.5	M6	45
25-10B2				2.5x2	3816	7968	60	23	M8x12	94	40	60	10	10	M6	54
28-6B1	28	6	3.969	2.5x1	1203	2796	60	22	M8x12	42	40	18	8	10	M6	50
28-6B2				2.5x2	2184	5592	60	22	M8x12	67	40	40	8	10	M6	50
32-10B1	32	10	6.350	2.5x1	2413	5172	70	26	M8x12	64	50	45	10	12	M6	62
32-10B2				2.5x2	4379	10345	70	26	M8x12	94	50	60	10	12	M6	67
36-10B2	36			2.5x2	4592	11403	86	29	M10x16	96	60	60	11	17	M6	67
45-12B2	45	12	7.144	2.5x2	5963	16110	100	36	M12x20	115	75	75	13	20.5	M6	80



## 7.5 Dimensions for Stock Rolled Ballscrews

**F S I** **TYPE** (DIN 69051 part 5 form B)

◀ Stock

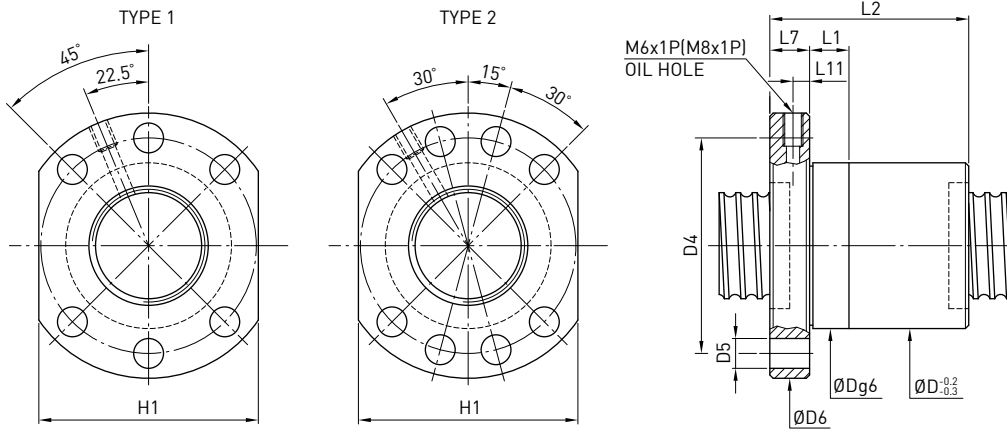

Model	Size		Ball Dia.	Circuits	Dynamic Load 1x10 <sup>6</sup> revs C [ kgf ]	Static Load Co [ kgf ]	D	D4	Flange Hole No.	D5	D6	H1	L1	L2	L7	L11	M-Oil Hole
	Nominal Dia.	Lead															
16-5T3	16			3	1000	2000	28	38	6	5.5	48	40	10	40	10	5	M6x1P
20-5T3	20			3	1160	2660	36	47	6	6.6	58	44	10	44	10	5	M6x1P
20-5T4	20	5	3.175	4	1490	3550	36	47	6	6.6	58	44	10	52	10	5	M6x1P
25-5T3	25			3	1320	3490	40	51	6	6.6	62	48	10	44	10	5	M6x1P
25-5T4	25			4	1690	4660	40	51	6	6.6	62	48	12	52	10	5	M6x1P
25-10T3	25	10	4.763	3	2160	4860	40	51	6	6.6	62	48	16	65	10	5	M6x1P
32-5T3	32			3	1500	4660	50	65	6	9	80	62	10	46	12	6	M6x1P
32-5T4	32			4	1920	6210	50	65	6	9	80	62	10	53	12	6	M6x1P
32-5T6	32			6	2730	9320	50	65	6	9	80	62	10	66	12	6	M6x1P
32-10T3	32	10	6.350	3	3650	8660	50	65	6	9	80	62	16	74	12	6	M6x1P
32-10T4	32	10	6.350	4	4680	11550	50	65	6	9	80	62	16	85	12	6	M6x1P
40-5T4	40			4	2110	7770	63	78	8	9	93	70	10	53	14	7	M8x1P
40-5T6	40			6	2990	11650	63	78	8	9	93	70	10	66	14	7	M8x1P
40-10T3	40	10	6.350	3	4030	10680	63	78	8	9	93	70	16	74	14	7	M8x1P
40-10T4	40	10	6.350	4	5170	14240	63	78	8	9	93	70	16	87	14	7	M8x1P
50-5T4	50			4	2330	9990	75	93	8	11	110	85	10	57	16	8	M8x1P
50-5T6	50			6	3310	14980	75	93	8	11	110	85	10	70	16	8	M8x1P
50-10T3	50			3	4590	14000	75	93	8	11	110	85	16	78	16	8	M8x1P
50-10T4	50			4	5880	18660	75	93	8	11	110	85	16	89	16	8	M8x1P
50-10T6	50			6	8330	28000	75	93	8	11	110	85	16	112	16	8	M8x1P

\* The calculation for dynamic load and static load is based on DIN69051.

**R S I** TYPE (with V-thread)

◀ Stock

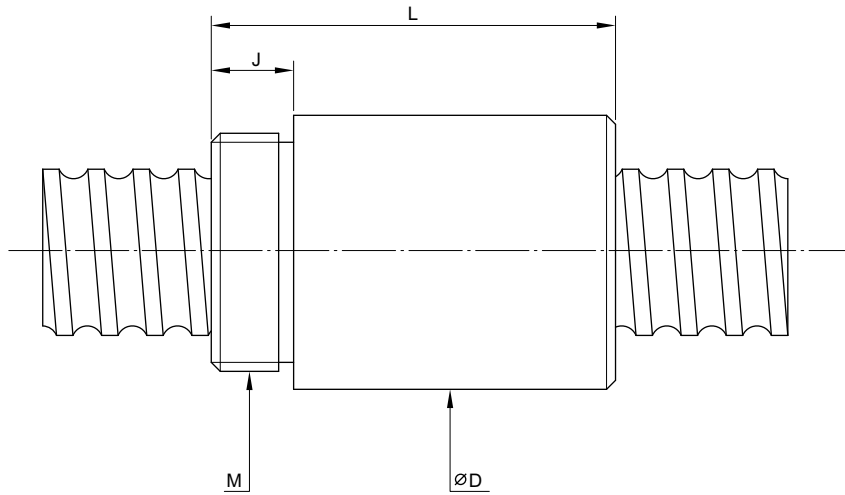

Model	Size		Ball Dia.	Circuits	Dynamic Load 1x10 <sup>6</sup> revs C ( kgf )	Static Load Co ( kgf )	L	D	M	J
	Nominal Dia.	Lead								
8-2.5T2	8	2.5	2.000	2	133	178	23.5	17.5	M15x1P	7.5
10-2.5T2	10			2	178	263	25	19.5	M17x1P	7.5
10-4T2	10	4	2.381	2	198	282	32	24	M22x1P	10

**R S B TYPE** (with V-thread)

◀ Stock

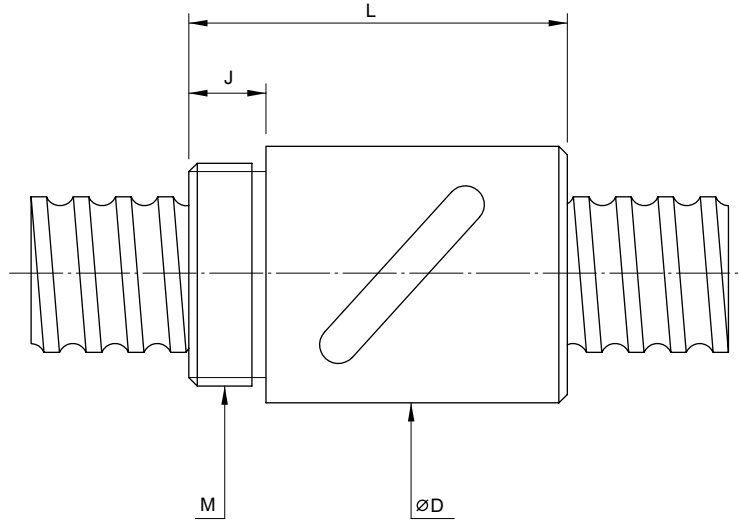

Model	Size		Ball Dia.	Circuits	Dynamic Load 1x10 <sup>6</sup> revs C ( kgf )	Static Load Co ( kgf )	L	D	M	J
	Nominal Dia.	Lead								
12-4B1	12	4	2.381	2.5x1	344	574	34	25.5	M20x1P	10



# 8 Ballscrew Retrofit Kits for Manual Milling Machine

## 8.1 Precision Ground Ballscrew Set

1. Precision ground, lead accuracy within  $\pm 0.0005''$  /ft.
2. Stock size meet various CNC systems' requirements.
3. High strength and long service life.

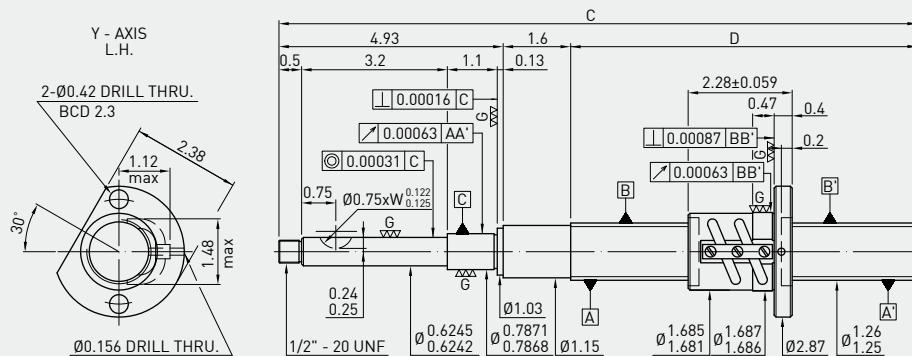
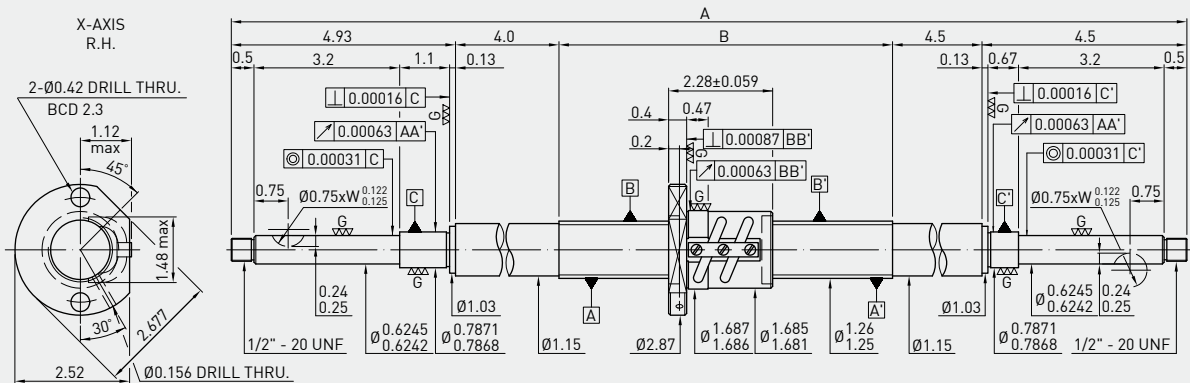

unit: inch

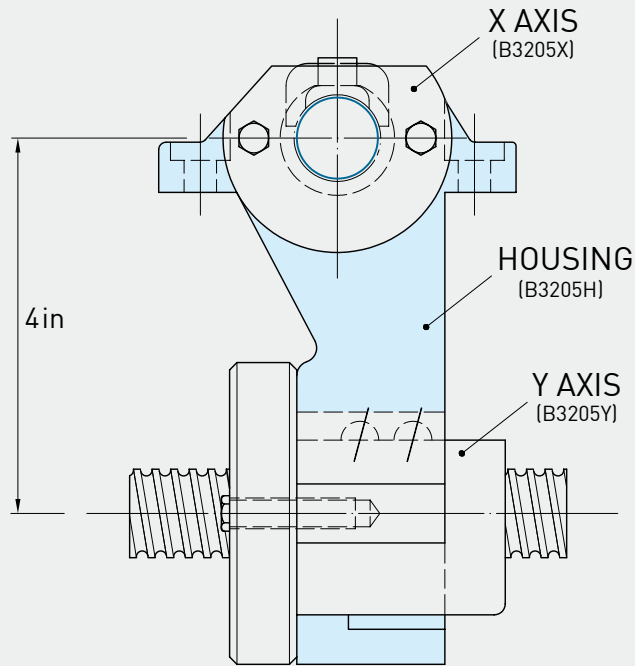

Traverse Screw (X Axis) in			
Traverse Screw	A	B	Part Number
32	42	24.07	B3205X-32
36	46	28.07	B3205X-36
42	52	34.07	B3205X-42
48	58	40.07	B3205X-48

Crossfeed Screw (Y Axis) in.			
Table Size	C	D	Part Number
9	20.3	13.77	B3205Y-9
12	23.3	16.77	B3205Y-12
16	27.3	20.77	B3205Y-16

P.C.Dia.	1.28"
Ball Dia.	0.125"
Lead Angle	2.84°
Circuits	2.5x2
Lead	5TPI
Static Load	12491 lbf
Dynamic Load(1x10 <sup>6</sup> revs)	4158 lbf
Lead Accuracy	0.0003"/2π; 0.0005"/ft
Drag Torque(Preload)	3.5in-lb (280lbs)

## 9 Multi-Solutions

### 9.1 Super S Series

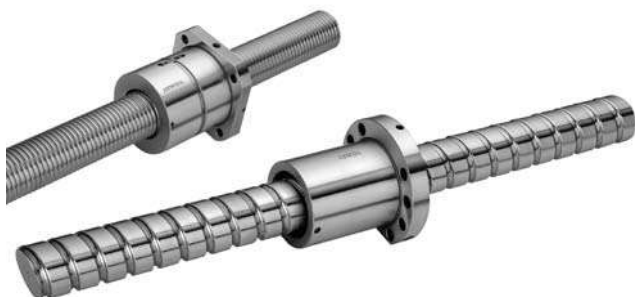

U.S.A. Patent No. 6561054  
Taiwan Patent No. 231845  
Taiwan Patent No. 233472  
Taiwan Patent No. 245857  
Taiwan Patent No. 115652  
Japan Patent No. 3117738

#### • Application:

CNC Machinery, Industrial Machinery, Electronic Machinery, Precision Machine and other High Speed Machinery.

#### • Features:

##### 1. Low noise (5~7dB lower than traditional series):

The patent design of return unit can absorb noises caused by the impact of the ballnut's balls, greatly reducing the noise intensity.

##### 2. Space-saving and weight-lightening design:

The ballnut diameter is 18%~32% smaller than traditional series.

##### 3. Dm-N value up to 220,000:

The patent design of the return unit can improve the strength of the return structure, achieving a Dm-N value of up to 220,000.

##### 4. High acceleration and deceleration velocity:

The pathway of specialized return unit, as well as the ballnut's strengthened design diminish the impact experienced by the balls, Hence, it can sustain peak performance in more rigorous operating environments, such as high acceleration and deceleration.

##### 5. Accuracy grade:

Precision ground ballscrews available in JIS Grade C0~C7; Rolled ballscrews available in JIS Grade C6~C10.

#### • Pattern Nomenclature:

Ex: R40-10K4 -FSC -1200 -1600 - 0.008



#### • Performance:

Specification: 2R40 - 40K4 - DFSC - 1200 -1600 - 0.008

Lead: 40 mm

Acceleration: 1g (9.8m/sec<sup>2</sup>)

Dm-N Value: 120,000

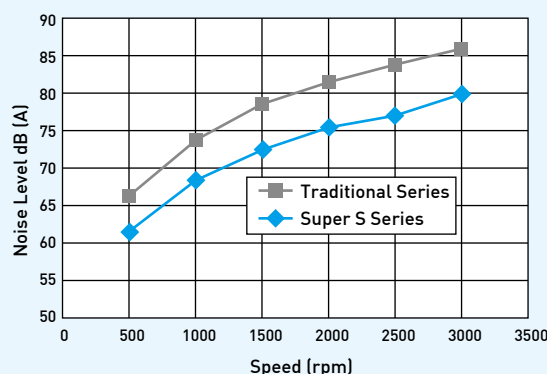
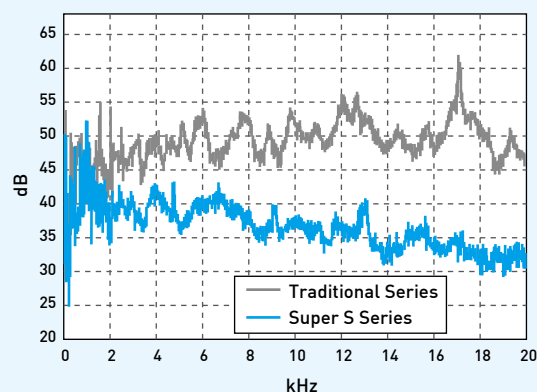

FSC TYPE

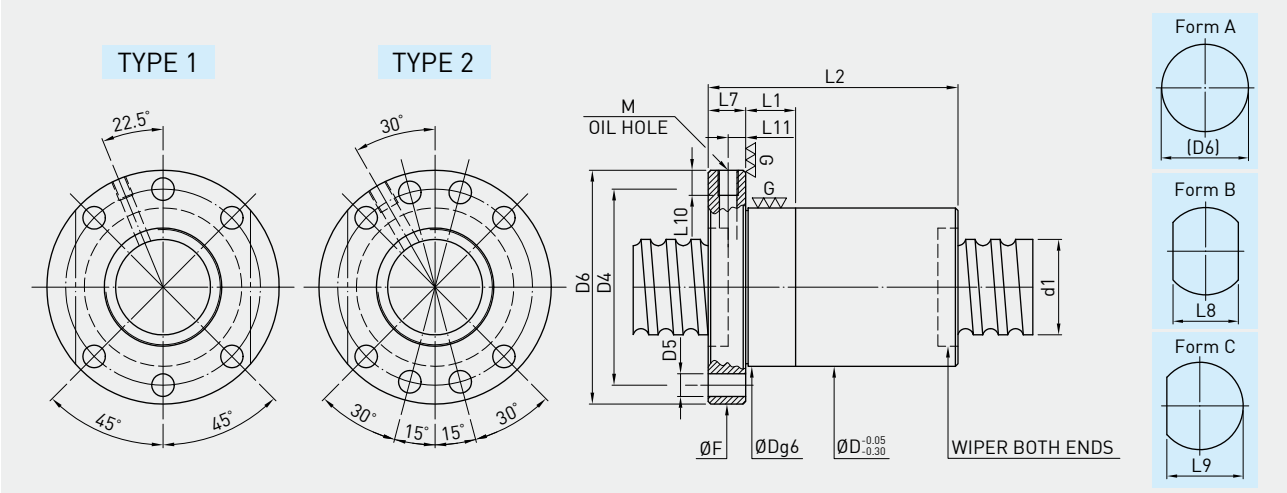

Model	Size		PCD	RD	Ball Dia.	Circuits	Rigidity K (kgf/µm)	Dynamic Load C(kgf)	Static Load Col(kgf)	Nut			Flange			Oil Hole			Double starts	
	Nominal Dia.	Lead								D	L1	L2	TYPE	Form A(D6)	Form B(L8)	Form C(L9)	L7	D4		D5
14-10K3	14	10	14.6	10.724		3	24	920	1790	28	10	46	48	40	44	38				
15-10K3	15	10	15.6	12.324	3.175	3	25	960	1930	34	10	44	57	43	50					
15-20K2		20				2	15	630	1256		10	50	57	43	50	45	5.5	M5x0.8P	6	
16-16K2	16	16	16.4	13.124	3.175	2	17	680	1385	34	10	47	57	43	50					
20-5K4		5				4	42	1490	3640		10	40								
20-10K3		10	20.6	17.324	3.175	3	32	1130	2660	36	10	47	58	44	51	47				
20-20K2	20	20				2	21	760	1730		10	57								●
20-6K5		6	20.8	16.744	3.969	5	58	2420	5660	42	10	49	64	50	57	53				
20-8K5		8	21	16.132	4.763	5	58	2960	6505	45	10	64	65	51	58	54				
25-5K4		5				4	49	1650	4612		10	43								
25-10K3		10				3	38	1260	3370		10	50				10			5	
25-15K5		15	25.6	22.324	3.175	5	63	1980	5730	40	10	90	62	48	55	51				
25-20K3		20				3	39	1260	3436		10	80								●
25-25K2		25				2	25	840	2170		10	69								●
25-6K5		6				5	68	2720	7192	45	10	50	65	51	58	54				
25-8K5		8				5	70	2710	7170	48	10	62	68	54	61	57	6.6			
25-10K4		10	25.8	21.744	3.969	4	56	2210	5660		10	60								
25-12K4		12				4	56	2200	5640	45	10	67	65	51	58	54				
25-16K3		16				3	42	1670	4127		10	71								
25-20K3		20				3	43	1710	4290		10	80								
25-8K5		8	26	21.132	4.763	5	72	3480	8683	50	10	64	70	56	64	60				
28-6K5		6	28.8	24.744	3.969	5	74	2840	7966		10	49								
28-8K5		8				5	79	3690	9780	50	10	62	80	62	71	65		M6x1P	8	
28-10K5		10	29	24.132	4.763	5	80	3680	9760	52	10	72								●
28-16K4		16				4	64	2970	7661	50	10	92								
32-5K4		5				4	57	1840	5960	48	10	38	70	54	62	59				
32-5.08K4	5.08		32.6	29.324	3.175	4	57	1840	5940		10	39								
32-6K5		6				5	83	3090	9480	56	10	48	86	65	75.5	12	71		6	
32-8K5		8				5	84	3080	9460		10	59								
32-10K5		10				5	85	3080	9450		10	73								
32-15K4		15	32.8	28.744	3.969	4	69	2500	7440	50	10	90	80	62	71	65				●
32-20K3		20				3	52	1900	5430		20	87								●
32-32K2		32				2	34	1280	3530		20	87								●
32-40K2		40				2	32	1240	3440		20	94								●
32-8K5		8				5	84	3860	10914	55	10	64								
32-10K5		10				5	86	3850	10890		10	79								
32-12K5		12	33	28.132	4.763	5	87	3840	10870	56	20	88	86	65	75.5	71				
32-20K4		20				4	72	3190	8914	54	20	106								●
32-10K5		10				5	90	5640	14480		10	77								
32-12K5		12				5	90	5620	14450		20	87								
32-16K4		16	33.4	26.91	6.35	4	73	4570	11390	62	20	92	92	74	83	77				
32-20K4		20				4	70	4240	10854		20	107								
36-6K5		6	36.8	32.744	3.969	5	88	3240	10632	56	10	51	86	65	77	71				
36-10K5		10				5	98	6010	16440		20	80								
36-12K5		12				5	99	5990	16420		20	87								
36-16K5		16	37.4	30.91	6.35	5	100	5960	16350	66	20	109	96	73	84.5	81				
36-20K4		20				4	79	4840	12880		20	108								
36-36K2		36				2	39	2540	6240		20	95								●
38-8K5		8	39	34.132	4.763	5	96	4190	13110	61	20	64	91	68	79.5	76		M8x1P	10	
38-10K4		10				4	81	5050	13790		20	70								
38-15K4		15				4	83	5020	13740		20	88								
38-16K5		16	39.4	32.91	6.35	5	104	6140	17340		20	108								●
38-20K4		20				4	83	4990	13660	63	25	108	93	70	81.5	78				●
38-25K4		25				4	83	4940	13560		25	127								●
38-40K2		40				2	40	2590	6560		25	103								●

Note: 1. Rigidity without preload: The axial load is calculated by 30% of dynamic load.  
 2. Circuits less than K5 also available.

# FSC TYPE

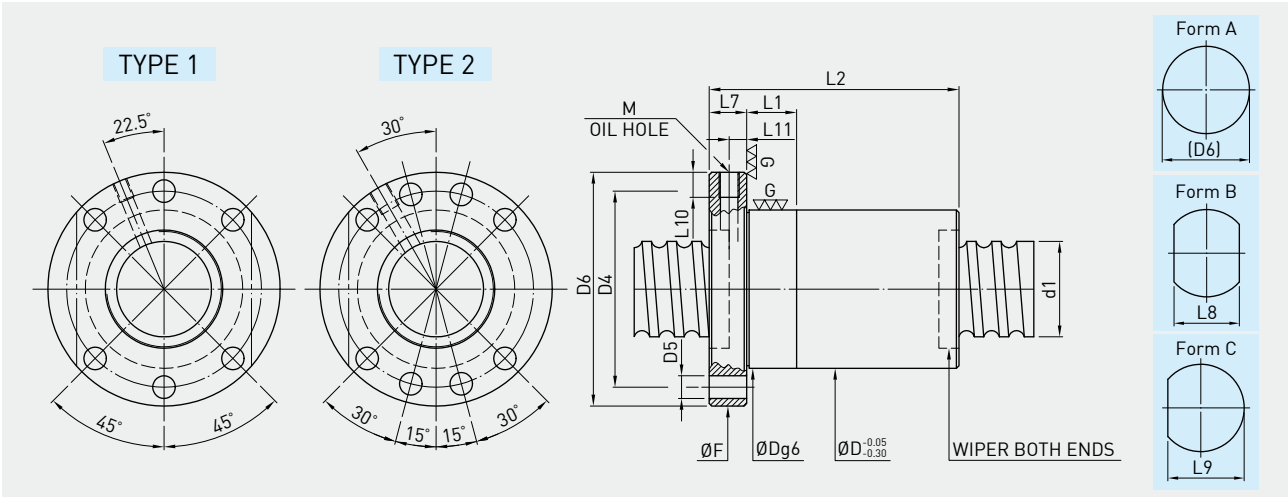

Model	Size		PCD	RD	Ball Dia.	Circuits	Rigidity K (kgf/μm)	Dynamic Load C (kgf)	Static Load Co (kgf)	Nut			Flange			Oil Hole			Double starts	
	Nominal Dia.	Lead								D	L1	L2	TYPE	Form A (D6)	Form B (L8)	Form C (L9)	L7	D4		D5
40-5K5	5	40.6	37.324	3.175	5	85	2470	9490	20	45										
40-6K5	6	40.8	36.744	3.969	5	95	3370	11780	63	20	52	93	70	81.5	78					
40-8K5	8				5	101	4360	14200	20	64										
40-10K5	10	41	36.132	4.763	5	102	4350	14180	20	80		91	68	79.5	76					
40-20K4	20				4	90	4300	14060	20	70										
40-16K5	16	41.2	35.522	5.556	5	107	5170	15510	68	20	108	98	75	86.5	83					
40-10K5	10				5	106	6340	18400	20	83				14	9				7	
40-12K5	12				5	108	6330	18380	20	86										
40-16K5	16	41.4	34.91	6.35	5	109	6300	18320	20	108		100	75	87.5	85					
40-20K4	20				4	87	5130	14440	20	110										
40-25K4	25				4	86	5080	14350	25	127										
40-40K2	40				2	42	2660	6940	25	101										
40-12K5	12	41.6	34.299	7.144	5	110	7430	20790	75	20	90	110	85	97.5	93					
45-8K5	8	46	41.132	4.763	5	109	4550	15860	70	20	66	105	80	92.5	90					
45-10K5	10				5	118	6810	21320	20	78										
45-12K5	12				5	119	6800	21290	20	89										
45-16K5	16	46.4	39.91	6.35	5	121	6780	21240	20	108										
45-20K4	20				4	98	5520	16760	75	25	108	110	85	97.5	93					
45-25K4	25				4	98	5480	16670	25	129										
45-40K3	40				3	71	4100	12020	25	145										
45-16K5	16	46.6	39.299	7.144	5	120	7810	23230	20	119										
45-20K4	20				4	97	6360	18330	80	25	113	117	92	104.5	100					
50-5K5	5	50.6	47.324	3.175	5	95	2700	11940	70	20	45	100	75	87.5	85					
50-8K5	8	51	46.132	4.763	5	116	4730	17530	75	20	74	110	85	97.5	93					
50-10K5	10				5	125	7050	23300	25	80										
50-12K5	12				5	127	7040	23280	25	90										
50-15K5	15				5	129	7030	23250	25	104										
50-16K5	16				5	129	7020	23230	25	109										
50-20K4	20	51.4	44.91	6.35	4	104	5720	18340	82	25	106	118	92	105	100					
50-25K4	25				4	104	5690	18260	25	129										
50-30K4	30				4	104	5650	18170	25	147										
50-35K3	35				3	80	4430	13840	25	133										
50-40K3	40				3	79	4390	13750	25	145										
50-30K2	30	51.6	44.299	7.144	2	53	3560	9960	82	25	92									
50-12K5	12	51.8	43.688	7.938	5	130	9480	28776	85	25	97									
50-16K5	16				5	132	9450	28710	25	112		121	95	108	103					
50-20K4	20	52.2	42.466	9.525	4	113	10670	31310	86	25	120									
55-16K5	16	56.4	49.91	6.35	5	139	7420	26157	82	25	104	118	92	105	100					
63-10K5	10				5	144	7720	29190	25	84										
63-12K5	12				5	147	7720	29180	25	94										
63-20K5	20	64.4	57.91	6.35	5	157	7850	30020	95	25	132	135	100	117.5	115					
63-40K2	40				2	62	3310	11100	25	110										
63-12K5	12	64.8	56.688	7.938	5	152	10520	36440	98	25	94	138	103	120.5	118					
63-16K4	16				4	132	11810	39320	25	100										
63-20K5	20	65.2	55.466	9.525	5	168	14410	49590	107	25	140	147	112	129.5	127					
70-16K4	16	72.2	62.466	9.525	4	141	12270	43299	115	25	105	155	120	137.5	135					
70-20K4	20				4	143	12250	43239	25	122										
80-10K5	10	81.4	74.91	6.35	5	166	8620	37980	110	25	80	150	115	132.5	25	130				
80-12K5	12	81.8	73.688	7.938	5	177	11740	47130	115	25	102	155	120	137.5	135					
80-20K4	20	82.2	72.466	9.525	4	160	13230	51060	120	25	122	165	130	147.5	145					

Note: 1. Rigidity without preload: The axial load is calculated by 30% of dynamic load.  
 2. Circuits less than K5 also available.

FDC TYPE

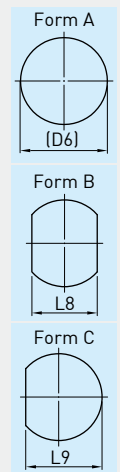
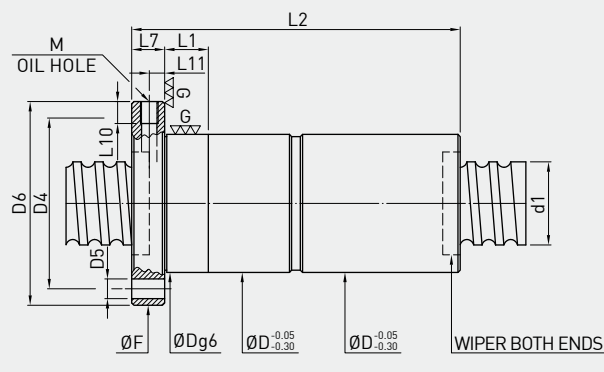
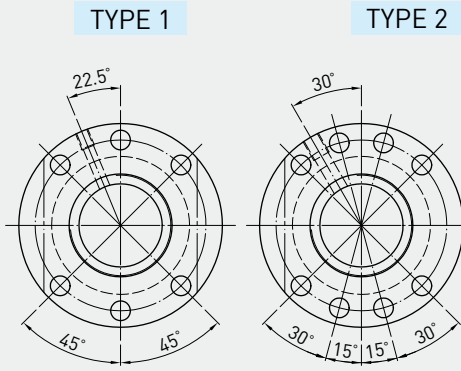

Model	Size		PCD	RD	Ball Dia.	Circuits	Rigidity K (kgf/μm)	Dynamic Load C(kgf)	Static Load Cok(kgf)	Nut			Flange			Oil Hole			Double starts		
	Nominal Dia.	Lead								D	L1	L2	TYPE	Form A (D6)	Form B (L8)	Form C (L9)	L7	D4		D5	M
14-10K3	14	10	14.6	10.724		3	31	920	1790	28	10	96		48	40	44		38			
15-10K3	15	10	15.6	12.324	3.175	3	33	960	1930	34	10	92									
15-20K2		20				2	20	630	1256	10	10	104		57	43	50		45	5.5	M5x0.8P	6
16-16K2	16	16	16.4	13.124	3.175	2	23	680	1385	34	10	98									
20-5K4		5				4	55	1490	1642		10	84									
20-10K3		10	20.6	17.324	3.175	3	42	1130	2660	36	10	98		58	44	51		47			
20-20K2	20	20				2	27	760	1730	10	10	116									
20-6K5		6	20.8	16.744	3.969	5	77	2420	5660	42	10	102		64	50	57		53			●
20-8K5		8	21	16.132	4.763	5	77	2960	6505	45	10	132		65	51	58		54			●
25-5K4		5				4	65	1650	4612		10	90									
25-10K3		10				3	50	1260	3370		10	104									
25-15K5		15	25.6	22.324	3.175	5	83	1980	5730	40	10	184		62	48	55	10	51			5
25-20K3		20				3	51	1260	3436		10	164									●
25-25K2		25				2	32	840	2170		10	142									●
25-6K5		6				5	91	2720	7192	45	10	104		65	51	58		54			
25-8K5		8				5	92	2710	7170	48	10	128		68	54	61		57	6.6		
25-10K4	25	10	25.8	21.744	3.969	4	74	2210	5660		10	124									
25-12K4	28	12				4	74	2200	5640		10	138		65	51	58		54			
25-16K3		16				3	55	1670	4127	45	10	146									
25-20K3		20				3	55	1710	4290		10	164									
25-8K5		8	26	21.132	4.763	5	96	3480	8683	50	10	132	1	70	56	64		60			
28-6K5		6	28.8	24.744	3.969	5	93	2840	7966		10	102									
28-8K5		8				5	104	3690	9780		10	128									
28-10K5		10	29	24.132	4.763	5	105	3680	9760	50	10	148		80	62	71		65			M6x1P
28-16K4		16				4	84	2970	7661		10	188									●
32-5K4		5				4	77	1840	5960		10	80									
32-5.08K4		5.08	32.6	29.324	3.175	4	77	1840	5940	48	10	82		70	54	62		59			
32-6K5		6				5	111	3090	9480	56	10	100		86	65	75.5	12	71			6
32-8K5		8				5	112	3080	9460		10	122									
32-10K5		10				5	113	3080	9450		10	150									
32-15K4		15	32.8	28.744	3.969	4	91	2500	7440	50	10	184		80	62	71		65			●
32-20K3		20				3	68	1900	5430		20	178									●
32-32K2		32				2	44	1280	3530		20	178									●
32-40K2		40				2	42	1240	3440		20	192									●
32-8K5		8				5	112	3860	10914	55	10	132									
32-10K5		10				5	113	3850	10890		10	162									
32-12K5		12	33	28.132	4.763	5	114	3840	10870	56	20	180		86	65	75.5		71			
32-20K4		20				4	94	3190	8914	54	20	216									●
32-10K5		10				5	119	5640	14480		10	158									
32-12K5		12				5	119	5620	14450		10	178									
32-16K4		16	33.4	26.91	6.35	4	96	4570	11390	62	20	188		92	74	83		77			
32-20K4		20				4	71	4240	10854		20	218									
36-6K5		6	36.8	32.744	3.969	5	118	3240	10632	56	10	106		86	65	77		71			
36-10K5		10				5	130	6010	16440		20	164									
36-12K5		12				5	131	5990	16420		20	178									
36-16K5		16	37.4	30.91	6.35	5	132	5960	16350	66	20	222		96	73	84.5	14	81			
36-20K4		20				4	105	4840	12880		20	220									
36-36K2		36				2	51	2540	6240		20	194									●
38-8K5		8	39	34.132	4.763	5	127	4190	13110	61	20	132	2	91	68	79.5		76			M8x1P
38-10K4		10				4	107	5050	13790		20	144									
38-15K4		15				4	109	5020	13740		20	180									
38-16K5		16				5	137	6140	17340		20	220									
38-20K4		20	39.4	32.91	6.35	4	110	4990	13660	63	25	220		93	70	81.5		78			●
38-25K4		25				4	109	4940	13560		25	258									●
38-40K2		40				2	53	2590	6560		25	210									●

Note: 1. Rigidity with preload: The axial load is calculated by 10% of dynamic load.  
 2. Circuits less than K5 also available.

FDC TYPE

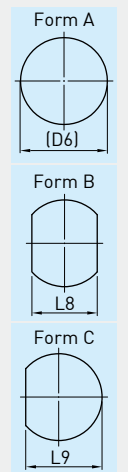
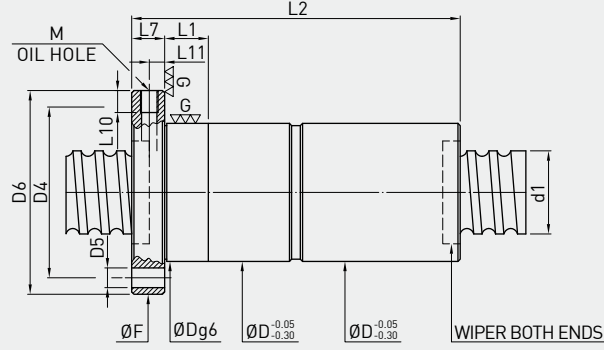
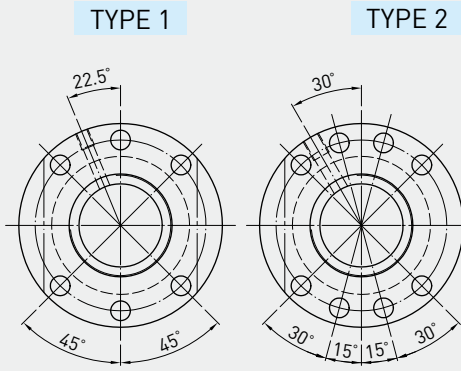

Model	Size		PCD	RD	Ball Dia.	Circuits	Rigidity K (kgf/μm)	Dynamic Load C(kgf)	Static Load Co(kgf)	Nut			Flange					Oil Hole			Double starts	
	Nominal Dia.	Lead								D	L1	L2	TYPE	Form A (D6)	Form B (L8)	Form C (L9)	L7	D4	D5	M		L10
40-5K5	5	40.6	37.324	3.175	5	114	2470	9490	20	95												
40-6K5	6	40.8	36.744	3.969	5	127	3370	11780	63	20	109		93	70	81.5		78					
40-8K5	8				5	135	4360	14200	20	133												
40-10K5	10	41	36.132	4.763	5	136	4350	14180	61	20	164		91	68	79.5		76					
40-20K4	20				4	119	4300	14060	20	144												
40-16K5	16	41.2	35.522	5.556	5	141	5170	15510	68	20	220		98	75	86.5		83					
40-10K5	10				5	141	6340	18400	20	171						14	9				7	
40-12K5	12				5	142	6330	18380	20	177												
40-16K5	16	41.4	34.91	6.35	5	143	6300	18320	70	20	221		100	75	87.5		85					
40-20K4	20				4	115	5130	14440	20	225												
40-25K4	25				4	114	5080	14350	25	259												
40-40K2	40				2	56	2660	6940	25	207												
40-12K5	12	41.6	34.299	7.144	5	146	7430	20790	75	20	185		110	85	97.5		93					
45-8K5	8	46	41.132	4.763	5	145	4550	15860	70	20	137		105	80	92.5		90					
45-10K5	10				5	156	6810	21320	20	161												
45-12K5	12				5	158	6800	21290	20	183												
45-16K5	16	46.4	39.91	6.35	5	160	6780	21240	20	221												
45-20K4	20				4	129	5520	16760	75	25	221		110	85	97.5		93					
45-25K4	25				4	129	5480	16670	25	263												
45-40K3	40				3	93	4100	12020	25	295												
45-16K5	16	46.6	39.299	7.144	5	159	7810	23230	20	243												
45-20K4	20				4	128	6360	18330	80	25	230		117	92	104.5		100					
50-5K5	5	50.6	47.324	3.175	5	129	2700	11940	70	20	95		100	75	87.5		85					
50-8K5	8	51	46.132	4.763	5	154	4730	17530	75	20	153		110	85	97.5		93					
50-10K5	10				5	166	7050	23300	25	166												
50-12K5	12				5	169	7040	23280	25	186						16	11	M8×1P		10	8	
50-15K5	15				5	171	7030	23250	25	214												
50-16K5	16				5	171	7020	23230	25	224												
50-20K4	20	51.4	44.91	6.35	4	138	5720	18340	82	25	218		118	92	105		100					
50-25K4	25				4	134	5690	18260	25	263												
50-30K4	30				4	136	5650	18170	25	299												
50-35K3	35				3	105	4430	13840	25	271												
50-40K3	40				3	104	4390	13750	25	295												
50-30K2	30	51.6	44.299	7.144	2	70	3560	9960	25	190												
50-12K5	12	51.8	43.688	7.938	5	173	9480	28776	85	25	200											
50-16K5	16				5	175	9450	28710	25	229			121	95	108		103					
50-20K4	20	52.2	42.466	9.525	4	149	10670	31310	86	25	245											
55-16K5	16	56.4	49.91	6.35	5	185	7420	26157	82	25	213		118	92	105		100					
63-10K5	10				5	192	7720	29190	25	174												
63-12K5	12				5	196	7720	29180	25	194												
63-20K5	20	64.4	57.91	6.35	5	208	7850	30020	95	25	270		135	100	117.5		115					
63-40K2	40				2	82	3310	11100	25	226												
63-12K5	12	64.8	56.688	7.938	5	202	10520	36440	98	25	194		138	103	120.5		118					
63-16K4	16				4	175	11810	39320	25	206												
63-20K5	20	65.2	55.466	9.525	5	222	14410	49590	107	25	286		147	112	129.5		127					
70-16K4	16	72.2	62.466	9.525	4	187	12270	43299	115	25	216											
70-20K4	20				4	190	12250	43239	25	250												
80-10K5	10	81.4	74.91	6.35	5	223	8620	37980	110	25	170		150	115	132.5	25	130					
80-12K5	12	81.8	73.688	7.938	5	238	11740	47130	115	25	210		155	120	137.5		135					
80-20K4	20	82.2	72.466	9.525	4	212	13230	51060	120	25	250		165	130	147.5		145					

Note: 1. Rigidity with preload: The axial load is calculated by 10% of dynamic load.  
 2. Circuits less than K5 also available.

## 9.2 E2 Self - lubricant

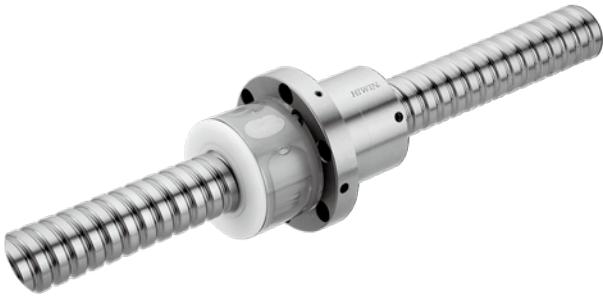

### • Features:

#### • Cost savings:

The E2 series saves cost by eliminating piping joint systems, change and waste disposal, and by reducing oil purchases.

#### • Greatly extends the maintenance period:

The E2 series will supply proper lubrication for long periods of time extending the maintenance period.

#### • Easy maintenance:

The special construction of the E2 design requires no tools to replace the oil cartridge. There is no disassembly required when adding the E2 option.

#### • Ideal lubrication position:

The lubrication point is located inside the ball nut allowing for the lubrication to be firmly applied onto the ball tracks.

#### • Effortless and flexible installation:

The lubrication performs properly in every direction so there are no restrictions when installing the E2.

#### • Clean and environmentally friendly:

Prevents oil leakage, making the E2 the ideal solution for clean room environments.

#### • Interchangeable oil selection:

The replaceable oil cartridge can be refilled with any approved lubrication oil.

#### • Applications for special environments:

The lubrication oil can be combined with grease for better results, especially in dusty, dirty, or wet environments.

#### • Characteristic of lubrication oil:

The E2 self-lubrication cartridge is equipped with synthetic hydrocarbon based oil. The lubricate oil has a viscosity grade of ISO VG680.

The E2 is compatible with mineral, hydrocarbon, and ester based greases. The E2 can accept synthetic oils with stable characteristics. A high viscosity grade will work well in conditions where there are high and low temperatures.

The low fluid draft factor prevents excessive power consumption and deters against corrosion and rust.

A compatible lubricate oil with the same viscosity grade can also be used in the replaceable cartridge.

### • Performance:

The E2 series will extend the maintenance period by supplying proper lubrication for long periods of time.

Test condition :	
Specification	R40-40K2-FSC
Oil	Mobil SHC 636 (50C.C.)
Speed	3000 rpm
Stroke	1000mm

E2 Performance Test

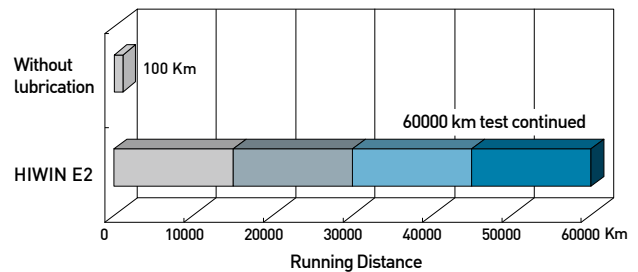

\* Note : above test with no grease added

### • Lubricant oil characteristics:

The E2 self-lubricant cartridge is equipped with synthetic hydrocarbon based oil. The lubricant oil has a viscosity grade of ISO VG680.

- The E2 is compatible with mineral, hydrocarbon, and ester based greases.
- The E2 can accept synthetic oils with stable characteristics.
- A high viscosity grade will work well in conditions where there are high and low temperatures.
- The low fluid draft factor prevents excessive power consumption.
- Anti-corrosion and rust.

◇ A compatible lubricate oil with the same viscosity grade can also be used in the replaceable cartridge.



• **Application:**

- Machine tools
- Industrial machinery : printing machine, paper-processing machine, automatic machine, textile machine, cutting and grinding machines, etc.
- Electronic machinery : robots, measuring equipment, X-Y tables, etc.
- Miscellaneous: medical equipment, factory automation equipment, etc.

• **Temperature range:**

The ideal E2 temperature range is from -10°C to 60 °C, please notify Hiwin engineers if the temperature requirement is out of this range.

• **Cost saving:**

The E2 series saves cost by eliminating piping joint systems, change and waste disposal, and by reducing oil purchases.

• **Specification number:**

Example: R40 - 20K3 - FSCE2 - 1200 - 1600 - 0.008

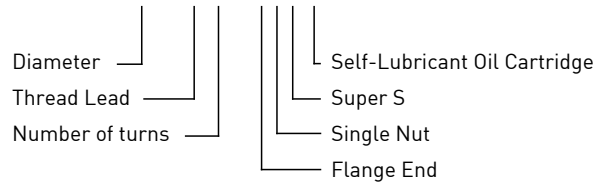

• **Specification:**

Nut type : FSV, FDV, FSW, FDW, PFDW, OFSW, Super S  
Please contact HIWIN engineers with other specification needs.

In order to get the good lubrication efficiency; please notify HIWIN engineers of the ballscrew installation direction.

	Lubrication Piping System	Design and Installation of Lubricant Device	Cost of Oil Purchase	Change Cost	Waste Oil Disposal
<b>Forced Lubrication</b>	\$XXX	\$XXX	0.1c.c./min. x 480min./day x 280day/year x 5year x cost/c.c. = 67200c.c. cost/c.c. = \$XXX	3-5times/year x 5year x cost/time = 15-25cost/time = \$XXX	
<b>HIWIN E2 Self-Lubricant</b>	Cost of Oil Purchase				
	16-57c.c. x cost/c.c. = \$XXX				

Cost

**HIWIN E2 Precision Ground Ballscrews**

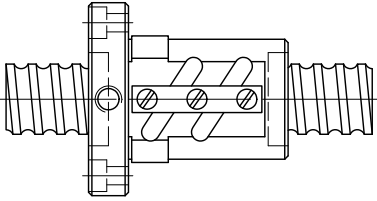
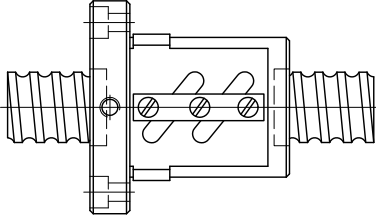
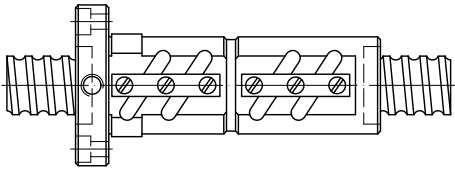
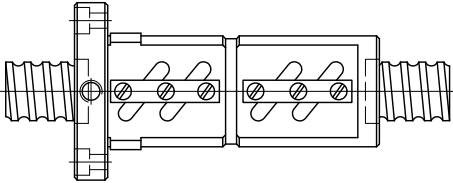
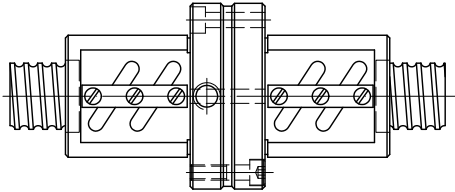
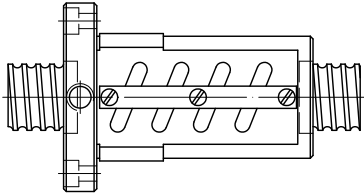
General Type	
<p><b>FSV</b></p>  <p>Flange end, single nut, tube above nut diameter</p>	<p><b>FSW</b></p>  <p>Flange end, single nut, tube within nut diameter</p>
<p><b>FDV</b></p>  <p>Flange end, double nut, tube above nut diameter</p>	<p><b>FDW</b></p>  <p>Flange end, double nut, tube within nut diameter</p>
<p><b>PFDW</b></p>  <p>Flange to flange, double nut, tube within nut diameter</p>	<p><b>OFSW</b></p>  <p>Offset pitch preload, flange end, single nut, tube within nut diameter</p>

\*Different design required by the drawing approval, please contact with HIWIN engineers for the other type listed above.  
(The specifications in this catalogue are subject to change without notification.)

Dimension table for E2

(Nut diameter is smaller than the oil cartridge)

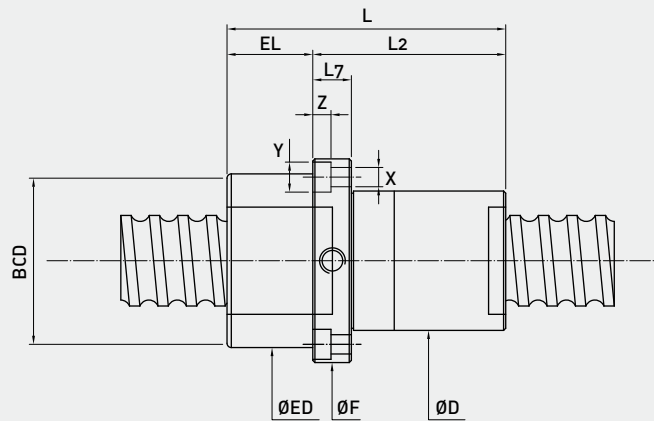

Please remove oil cartridge when installing the nut

Model	Specification			Nut Size									E2 Size		
	Nominal Dia.	Lead	Ball Dia.	D	L2	F	L7	BCD	X	Y	Z	EL	ED	L	
20-10K3	20	10	3.175	36	47	62	12	47	6.6	11	6.5	40	49	87	
20-20K2	20	20	3.175	36	56	62	12	47	6.6	11	6.5	40	49	96	
25-10K3	25	10	3.175	40	50	66	12	51	6.6	11	6.5	40	49	90	
25-25K2	25	25	3.175	40	69	66	12	51	6.6	11	6.5	40	49	109	
25-12K4	25	12	3.969	45	67	69	12	54	6.6	11	6.5	40	49	107	
32-5K4	32	5	3.175	48	38	77	12	59	9	14	8.5	40	62	78	
32-8K5	32	8	3.969	50	59	83	12	65	9	14	8.5	40	62	99	
32-10K5	32	10	3.969	50	73	83	12	65	9	14	8.5	40	62	113	
32-20K3	32	20	3.969	50	87	83	12	65	9	14	8.5	40	62	127	
32-32K2	32	32	3.969	50	87	83	12	65	9	14	8.5	40	62	127	
32-10K5	32	10	4.763	56	79	89	14	71	9	14	8.5	40	62	119	
32-12K5	32	12	4.763	56	88	89	14	71	9	14	8.5	40	62	128	
32-10K5	32	10	6.35	62	77	95	18	77	9	14	8.5	36	81	113	
32-12K5	32	12	6.35	62	87	95	18	77	9	14	8.5	36	81	123	
32-16K4	32	16	6.35	62	92	95	18	77	9	14	8.5	36	81	128	
32-20K3	32	20	6.35	62	87	95	18	77	9	14	8.5	36	81	123	
36-8K5	36	8	4.763	59	64	92	14	74	9	14	8.5	36	81	100	
36-10K5	36	10	6.35	66	80	99	18	81	9	14	8.5	36	81	116	
36-12K5	36	12	6.35	66	87	99	18	81	9	14	8.5	36	81	123	
36-16K5	36	16	6.35	66	109	99	18	81	9	14	8.5	36	81	145	
36-20K4	36	20	6.35	61	108	94	18	76	9	14	8.5	36	81	144	
36-36K2	36	36	6.35	61	95	94	18	76	9	14	8.5	36	81	131	
38-8K5	38	8	4.763	61	64	94	14	76	9	14	8.5	36	81	100	
38-16K5	38	16	6.35	63	108	96	18	78	9	14	8.5	36	81	144	
38-20K4	38	20	6.35	63	108	96	18	78	9	14	8.5	36	81	144	
38-25K4	38	25	6.35	63	127	96	18	78	9	14	8.5	36	81	162	
38-40K2	38	40	6.35	63	103	96	18	78	9	14	8.5	36	81	137	
40-8K5	40	8	4.763	63	64	96	14	78	9	14	8.5	36	81	100	
40-10K5	40	10	6.35	70	83	103	18	85	9	14	8.5	36	81	119	
40-12K5	40	12	6.35	70	86	103	18	85	9	14	8.5	36	81	122	
40-16K5	40	16	6.35	70	108	103	18	85	9	14	8.5	36	81	144	
40-20K4	40	20	6.35	70	110	103	18	85	9	14	8.5	36	81	146	
40-25K4	40	25	6.35	65	127	98	18	80	9	14	8.5	36	81	163	
40-40K2	40	40	6.35	65	101	98	18	80	9	14	8.5	36	81	137	
45-10K5	45	10	6.35	75	78	115	18	93	11	17.5	11	36	92	114	
45-12K5	45	12	6.35	75	89	115	18	93	11	17.5	11	36	92	125	
45-16K5	45	16	6.35	75	108	115	18	93	11	17.5	11	36	92	144	
45-20K4	45	20	6.35	75	108	115	18	93	11	17.5	11	36	92	144	
45-25K4	45	25	6.35	70	129	110	18	88	11	17.5	11	36	92	165	
45-40K3	45	40	6.35	70	145	110	18	88	11	17.5	11	36	92	181	
50-10K5	50	10	6.35	82	80	122	18	100	11	17.5	11	36	92	116	
50-12K5	50	12	6.35	82	90	122	18	100	11	17.5	11	36	92	126	
50-16K5	50	16	6.35	82	109	122	18	100	11	17.5	11	36	92	145	
50-20K4	50	20	6.35	82	106	122	18	100	11	17.5	11	36	92	142	
50-25K4	50	25	6.35	75	129	115	18	93	11	17.5	11	36	92	165	
50-30K4	50	30	6.35	75	147	115	18	93	11	17.5	11	36	92	183	
50-40K3	50	40	6.35	75	145	115	18	93	11	17.5	11	36	92	181	
50-30K2	50	30	7.144	82	92	122	18	100	11	17.5	11	36	92	128	

**Dimension table for E2**

(Nut diameter is larger than the oil cartridge)

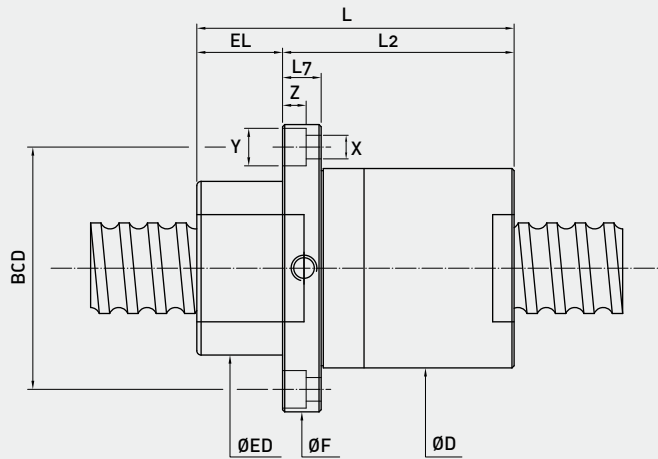

Model	Specification			Nut Size								E2 Size		
	Nominal Dia.	Lead	Ball Dia.	D	L2	F	L7	BCD	X	Y	Z	EL	ED	L
20-10K3	20	10	3.175	51	47	76	12	62	6.6	11	6.5	40	49	87
20-20K2	20	20	3.175	51	56	76	12	62	6.6	11	6.5	40	49	96
25-10K3	25	10	3.175	51	50	76	12	62	6.6	11	6.5	40	49	90
25-25K2	25	25	3.175	51	69	76	12	62	6.6	11	6.5	40	49	109
25-12K4	25	12	3.969	51	67	76	12	62	6.6	11	6.5	40	49	107
32-5K4	32	5	3.175	64	38	95	12	78	9	14	8.5	40	62	78
32-8K5	32	8	3.969	64	59	95	12	78	9	14	8.5	40	62	99
32-10K5	32	10	3.969	64	73	95	12	78	9	14	8.5	40	62	113
32-20K3	32	20	3.969	64	87	95	12	78	9	14	8.5	40	62	127
32-32K2	32	32	3.969	64	87	95	12	78	9	14	8.5	40	62	127
32-10K5	32	10	4.763	64	79	95	14	78	9	14	8.5	40	62	119
32-12K5	32	12	4.763	64	88	95	14	78	9	14	8.5	40	62	128
32-10K5	32	10	6.35	83	77	114	18	97	9	14	8.5	36	81	113
32-12K5	32	12	6.35	83	87	114	18	97	9	14	8.5	36	81	123
32-16K4	32	16	6.35	83	92	114	18	97	9	14	8.5	36	81	128
32-20K3	32	20	6.35	83	87	114	18	97	9	14	8.5	36	81	123
36-8K5	36	8	4.763	83	64	114	14	97	9	14	8.5	36	81	100
36-10K5	36	10	6.35	83	80	114	18	97	9	14	8.5	36	81	116
36-12K5	36	12	6.35	83	87	114	18	97	9	14	8.5	36	81	123
36-16K5	36	16	6.35	83	109	114	18	97	9	14	8.5	36	81	145
36-20K4	36	20	6.35	83	108	114	18	97	9	14	8.5	36	81	144
36-36K2	36	36	6.35	83	95	114	18	97	9	14	8.5	36	81	131
38-8K5	38	8	4.763	83	64	114	14	97	9	14	8.5	36	81	100
38-16K5	38	16	6.35	83	108	114	18	97	9	14	8.5	36	81	144
38-20K4	38	20	6.35	83	108	114	18	97	9	14	8.5	36	81	144
38-25K4	38	25	6.35	83	127	114	18	97	9	14	8.5	36	81	162
38-40K2	38	40	6.35	83	103	114	18	97	9	14	8.5	36	81	137
40-8K5	40	8	4.763	83	64	114	14	97	9	14	8.5	36	81	100
40-10K5	40	10	6.35	83	83	114	18	97	9	14	8.5	36	81	119
40-12K5	40	12	6.35	83	86	114	18	97	9	14	8.5	36	81	122
40-16K5	40	16	6.35	83	108	114	18	97	9	14	8.5	36	81	144
40-20K4	40	20	6.35	83	110	114	18	97	9	14	8.5	36	81	146
40-25K4	40	25	6.35	83	127	114	18	97	9	14	8.5	36	81	163
40-40K2	40	40	6.35	83	101	114	18	97	9	14	8.5	36	81	137
45-10K5	45	10	6.35	94	78	133	18	112	11	17.5	11	36	92	114
45-12K5	45	12	6.35	94	89	133	18	112	11	17.5	11	36	92	125
45-16K5	45	16	6.35	94	108	133	18	112	11	17.5	11	36	92	144
45-20K4	45	20	6.35	94	108	133	18	112	11	17.5	11	36	92	144
45-25K4	45	25	6.35	94	129	133	18	112	11	17.5	11	36	92	165
45-40K3	45	40	6.35	94	145	133	18	112	11	17.5	11	36	92	181
50-10K5	50	10	6.35	94	80	133	18	112	11	17.5	11	36	92	116
50-12K5	50	12	6.35	94	90	133	18	112	11	17.5	11	36	92	126
50-16K5	50	16	6.35	94	109	133	18	112	11	17.5	11	36	92	145
50-20K4	50	20	6.35	94	106	133	18	112	11	17.5	11	36	92	142
50-25K4	50	25	6.35	94	129	133	18	112	11	17.5	11	36	92	165
50-30K4	50	30	6.35	94	147	133	18	112	11	17.5	11	36	92	183
50-40K3	50	40	6.35	94	145	133	18	112	11	17.5	11	36	92	181
50-30K2	50	30	7.144	94	92	133	18	112	11	17.5	11	36	92	128

## 9.3 R1 Rotating Nut



### • Application:

Semi-conductor industries, Robots, Wood machines, Laser cutting machines, Transporting equipment.

### • Features:

#### 1. Compact and high positioning:

It is a compact design using nut and support bearing as an integral unit. 45-degree steel ball contact angle make a better axial load. Zero backlash and higher stiffness construction give a high positioning.

#### 2. Simple installation:

It is installed simply by fixing the nut on the housing with bolts.

#### 3. Rapid feed:

No inertial effect produced by the integral unit rotating and the shaft fixed. Can select smaller power to meet the rapid feed requirement.

#### 4. Stiffness:

Have a higher trust and moment stiffness, because the integral unit have an angular contact construction. There is no backlash while rolling.

#### 5. Quietness:

Special end cap design allows steel balls circulating inside the nut. Noise generated by high speed operation lower than ordinary ballscrew.

### • Specification:

Example: 2R40-40S2-DFSHR1-800-1000-0.018

↓  
**HIWIN** R1 code

## R1 ROTATING NUT

China Patent No. 422327  
Germany Patent No. 10108647.4  
Taiwan Patent No.166845  
U.S.A. Patent No. 6406188B1

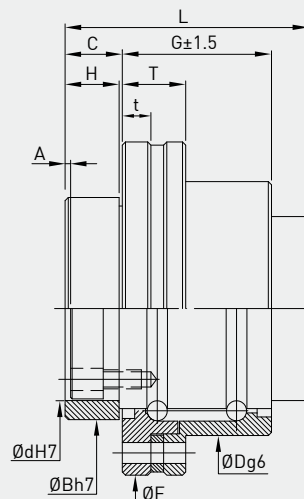
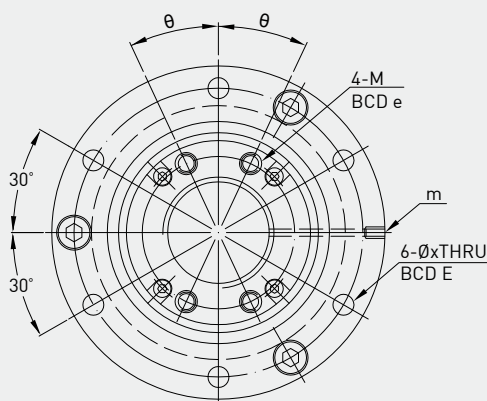

Model	Bearing		Nut				Flange			Bolt				Bush			Oil hole		
	Dynamic Load(kgF)	Static Load(kgF)	D	G	L	C	F	T	t	BCD-E	BCD-e	θ	M	X	d	B		H	A
16-16S2	1299	1826	52	25	44	11.4	68	13	6	60	26	20	M4x0.7P	4.5	33	40	11	2	M4x0.7P
20-20S2	1762	2531	62	30	50	12	78	13	6	70	31	20	M5x0.8P	4.5	39	50	11	2	M4x0.7P
25-25S2	1946	3036	72	36	63	16.5	92	13	6	81	38	20	M6x1P	5.5	47	58	15.5	2	M4x0.7P
32-32S2	3150	5035	80	47	80	21	105	20	9	91	48	25	M6x1P	6.6	58	66	20	3	M6x0.75P
40-40S2	4800	8148	110	62	98	22.5	140	20	9	123	61	25	M8x1.25P	9	73	90	21.5	3	M6x0.75P

## 9.4 Heavy Load Drive



### • Application:

High-load ball screw can be used for application on injection molding machines, die casting machines, general presses, power cylinders, robot ...

### • Features:

#### 1. Heavy Load:

A. 2-3 times load capacity than general standard series.

- B. High axial load and acceleration.
- C. Special lubrication design for short stroke.

#### 2. Accuracy:

JIS C5 and JIS C7

#### 3. High Speed Operation and High Life:

Enforced ball circulation systems for high speed condition and achieve long service life.

#### 4. Option:

Design in HIWIN Self-lubricant E2 Series.

## BALLSCREW FOR HEAVY-LOAD DRIVE

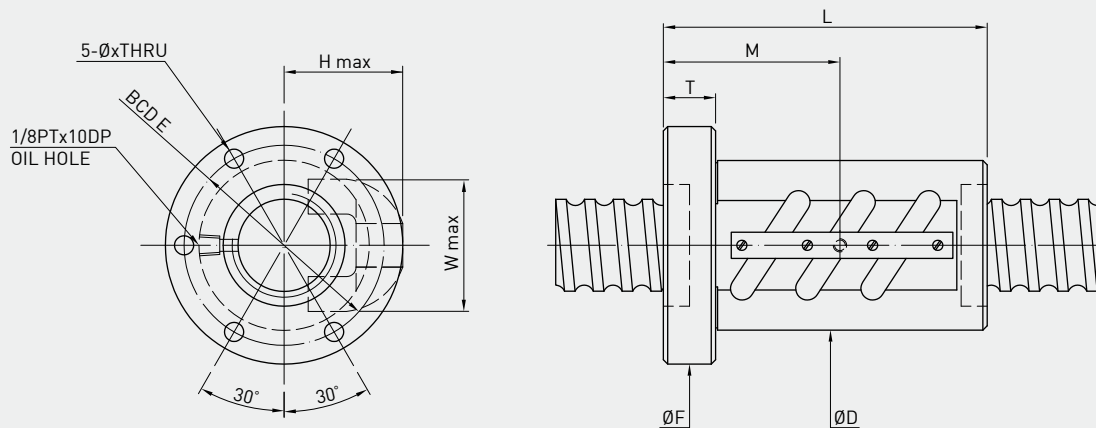

Model No.	Shaft diameter	Lead	Turns Circuits	Dynamic		Static		D	L	F	T	E	X	H	W	M
				kN	kgf	kN	kgf									
50-16B2	50	16	2.5x2	232	23700	647	66000	95	165	127	28	110	9	68	69	101
50-16B3		16	2.5x3	330	33600	971	99100	95	213	127	28	110	9	68	69	117
55-16B2	55	16	2.5x2	242	24700	703	71700	100	165	132	28	115	9	71	74	101
55-16B3		16	2.5x3	343	35000	1054	107600	100	213	132	28	115	9	71	74	117
63-16B2	63	16	2.5x2	260	26500	811	82800	105	165	137	28	120	9	73	82	101
63-16B3		16	2.5x3	368	37600	1217	124200	105	213	137	28	120	9	73	82	117
80-16B2	80	16	2.5x2	289	29500	1029	105000	120	170	158	32	139	11	81	98	106
80-16B3		16	2.5x3	409	41800	1543	157500	120	218	158	32	139	11	81	98	122
80-25B3	100	25	2.5x3	684	69800	2186	223100	145	338	185	40	165	11	102	100	140
100-16B3		16	2.5x3	453	46200	1949	198900	140	218	178	32	159	11	91	117	122
100-25B3	100	25	2.5x3	763	77800	2740	279600	159	338	199	40	179	11	109	118	140
100-25B4		25	2.5x4	977	99700	3654	372800	159	413	199	40	179	11	109	118	165

## 9.5 Cool Type

### 9.5.1 Extra High Dm-N Value Ballscrew - Cool Type I

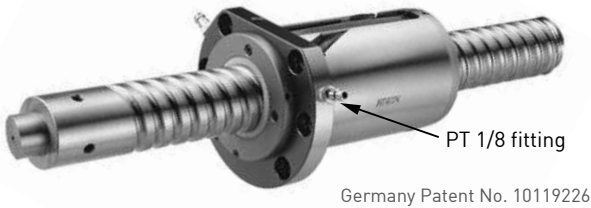

#### • Cool type I:

- New era for high speed ballscrew - achieving extra high Dm-N value (up to 200,000) and high positioning accuracy.
- Cool type I and a hollow shaft design.
- High speed machine tools and machining center.

#### • Design Principle:

The cool type series feature using forced cooling fluid to pass through the nut, which minimize heat generation and thermal expansion during ballscrew operation.

- Cool type I as shown in the Figure 9.1:

Flowing fluids are circulated in passages that inside the nut, and exchanging heat with the cooler as shown in the Figure 9.2 In cooperation with hollow shaft design, it makes high quality of thermal control and maintains high accuracy. That combination is the most suitable for high-speed machine tools.

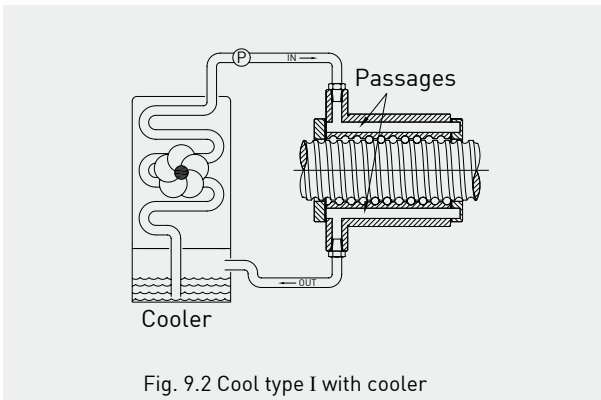
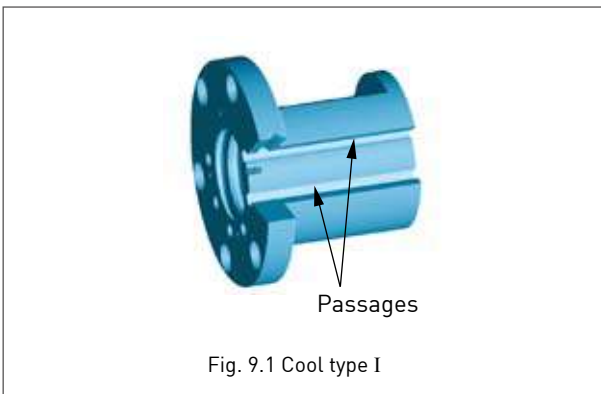

#### • Specification:

1. We recommend shaft diameter above  $\varnothing 32\text{mm}$  to cool type design.
2. Nut type: FSV, FSW, PFDW, OFSW, DFSV, FSH, FSI, etc.
3. Please contact HIWIN with other specification you need.
4. The cool type I, compared with the standard specifications, will make a minor external dimension change of the nut, please contact HIWIN.

#### • Specification number:

Example: R50 - 30C1 - OFSWC1 - 1180 - 1539 - 0.008



C1: HIWIN cool type ballscrew for type I

#### • Performance Comparison:

For high-speed machine tools, hollow shaft design only is not enough against heat generation and thermal expansion, because nut itself is a heat source, as shown in Figure 9.3.

#### Test condition :

specification :  $\varnothing 50$ , lead 30 mm  
 speed : 2500 rpm ( 75 m/min),  
 back and forth feed continuously  
 acceleration : 9.8 m/sec<sup>2</sup>  
 stroke : 1180 mm  
 preload : 205 kgf  
 moving weight : 300 kgf  
 cooling rate : oil 2.5 liter/min  
 inlet temperature : 16°C  
 room temperature : 25°C

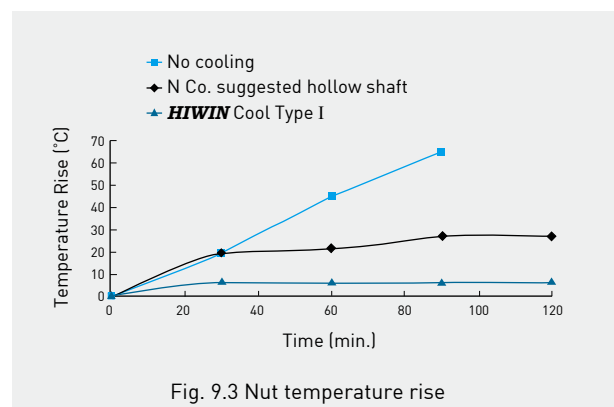
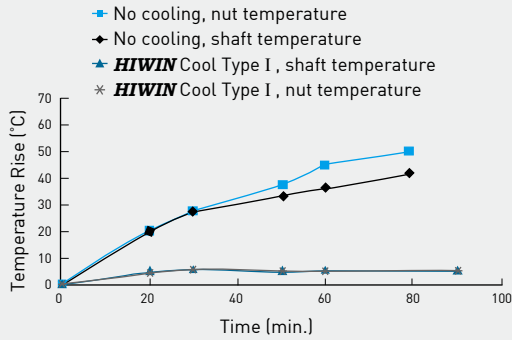

Fig. 9.3 Nut temperature rise

**Cool type I Performance (1)**

Specification: Ø50, lead 30 mm  
Dm-N value: 150,000  
Acceleration: 9.8 m/sec<sup>2</sup>



Cool type I : Temperature rise of ballscrew

**Cool type I Performance (2)**

Specification: Ø50, lead 30 mm  
Dm-N value: 200,000  
Acceleration: 9.8 m/sec<sup>2</sup>

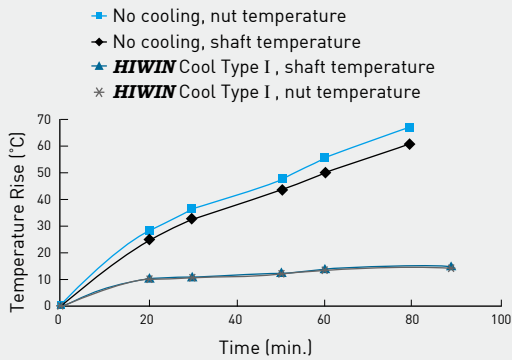

Cool type I : Temperature rise of ballscrew

**• Features:**

- 1. Optimized design for high reliability:**  
Use of computer simulation and FEM analysis, the cool type ballscrew features well thermal protection and high reliability.
- 2. Promote higher speed rotation and extra high Dm-N value (up to 200,000):**  
Cool type ballscrew will eliminate high-speed rotation aftereffect, i. e., thermal problem, and promote higher speed rotation.
- 3. Prevent thermal distortion:**  
Optimized heat transfer design to minimize heat generation and prevent thermal distortion.
- 4. Strengthen durability:**  
When operating repeatedly, friction between balls cause heat generation. That may be made balls oxidized or decarburized, and shortened the service life. Cool type ballscrew will strengthen durability under a cooling environment.
- 5. Extended lubricant life cycle:**  
When using lubrication, minimum heat generation further inhibits deterioration in the quality of lubrication and extends the lubricant life cycle.
- 6. Keep temperature uniform and reduce warm-up time:**  
When high-speed operation, nut and shaft cooling effect indeed keep feed-system temperature constant and reduce warm-up time.
- 7. Higher feeding accuracy:**  
Cooling effect of cool type ballscrew will stabilize against thermal expansion and equalize feeding accuracy.

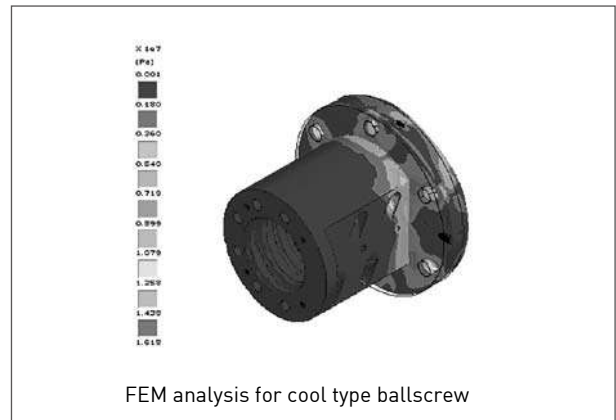



9.5.2 High Load Ballscrew - Cool Type II



Germany Patent No. 20119457.0  
Taiwan Patent No. 193878

• **Cool type II:**

- New era for ballscrew applied in electric - driven injection machine, presses, power units, and other replaceable hydraulic drives.
- Electric-driven injection machine, presses, power units and other replaceable hydraulic drives.

• **Design Principle:**

The cool type series feature using forced cooling fluid to pass through the nut, which minimize heat generation and thermal expansion during ballscrew operation.

• **Cool type II as shown in the Figure 9.4:**

Flowing fluids are circulated through a space, which inside the nut, and exchanging heat with the cooler as shown in the Figure 9.5. It is the most suitable for electric-driven injection machine, presses, and power units. The cool type II, compared with the standard specifications, will make a minor external dimension change of the nut. Please contact HIWIN .

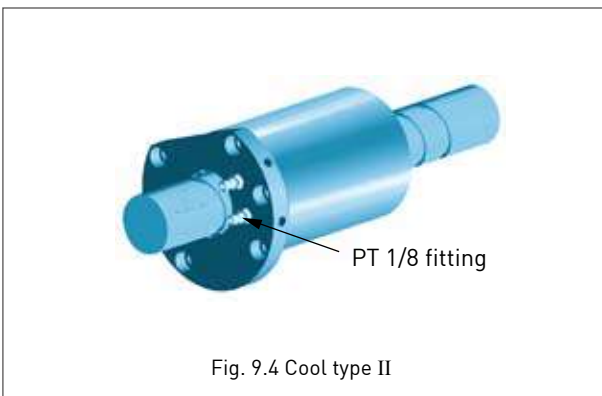

Fig. 9.4 Cool type II

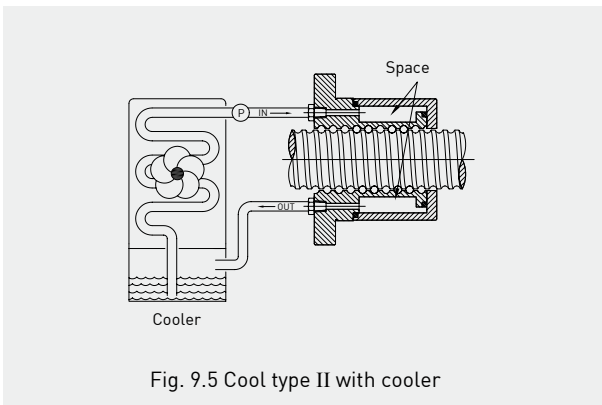

Fig. 9.5 Cool type II with cooler

• **Specification:**

1. We recommend shaft diameter above Ø32mm to cool type design.
2. Nut type: FSV, FSW, PFDW, OFSW, DFSV, FSH, FSI, etc.
3. Please contact HIWIN with other specification you need.
4. The cool type II, compared with the standard specifications, will make a minor external dimension change of the nut, please contact HIWIN.

• **Specification number:**

Example: R63 - 16B3 - RSWC2 - 400 - 600- 0.05

↓  
C2 : HIWIN cool type ballscrew for type II

• **Performance Comparison:**

**Test condition :**

- specification : Ø50, lead 30 mm
- speed : 1500 rpm ( 45 m/min),  
back and forth feed continuously
- acceleration : 4.9 m/sec<sup>2</sup>
- stroke : 300 mm
- preload : 205 kgf
- moving weight : 300 kgf
- cooling rate : oil 2.5 liter/min
- inlet temperature : 16°C
- room temperature : 25°C

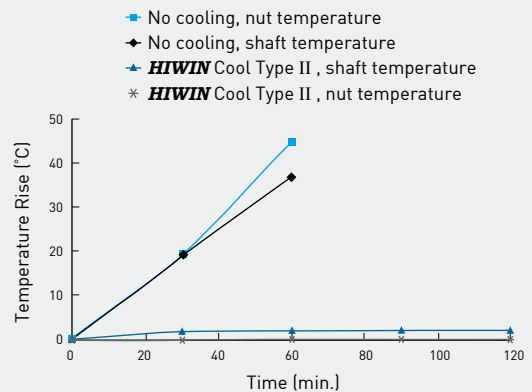

Fig. 9.6 Cool type II : Temperature rise of ballscrew

• **Features:**

1. **Optimized design for high reliability:**  
Use of computer simulation and FEM analysis, the cool type ballscrew features well thermal protection and high reliability.
2. **Promote higher speed rotation and extra high Dm-N value (up to 200,000):**  
Cool type ballscrew will eliminate high-speed rotation aftereffect, i. e., thermal problem, and promote higher speed rotation.
3. **Prevent thermal distortion:**  
Optimized heat transfer design to minimize heat generation and prevent thermal distortion.
4. **Strengthen durability:**  
When operating repeatedly, friction between balls cause heat generation. That may be made balls oxidized or decarburized, and shortened the service life. Cool type ballscrew will strengthen durability under a cooling environment.

5. **Extended lubricant life cycle:**

When using lubrication, minimum heat generation further inhibits deterioration in the quality of lubrication and extends the lubricant life cycle.

6. **Higher feeding accuracy:**

Cooling effect of cool type ballscrew will stabilize against thermal expansion and equalize feeding accuracy.

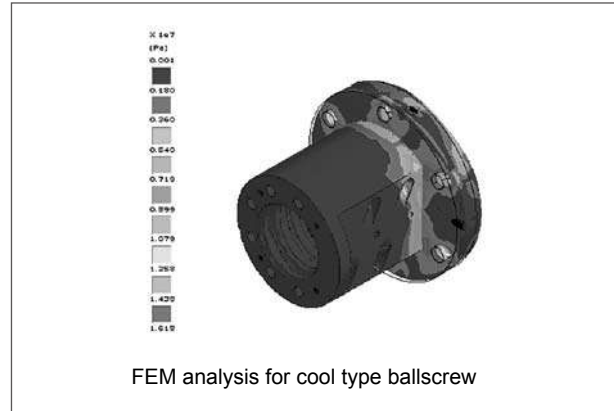

**Average Life Cycle for Injection Machine Ballscrew**

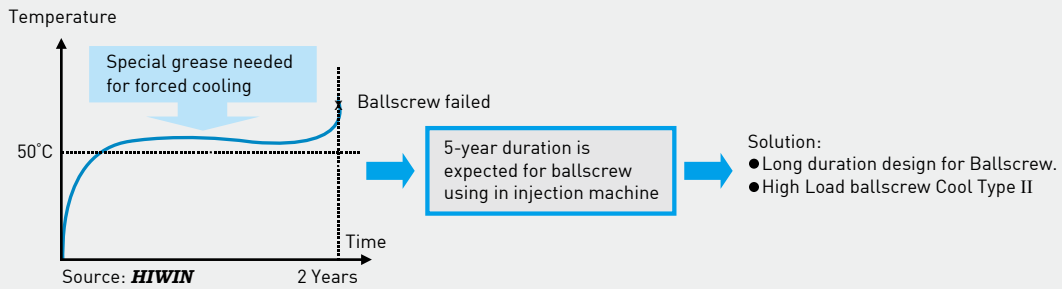

Fig 9.7 Life cycle for ballscrew using in general injection machine

# A Ballscrew Failure Analysis

## A1 Preface

In recent years, more and more ballscrews are installed in various machines to meet the requirements of higher accuracy and better performance. Ballscrews become one of the most widely used power transmission components. In CNC machines, ballscrews help improve their positioning accuracy and elongate their service life. Ballscrews are also increasingly used to replace ACME screws in manually operated machines.

A ballscrew is normally preloaded to minimize the backlash of machine movement. Even a high precision ballscrew will not provide good accuracy and long service life if it is not installed properly.

This article discusses primary ballscrew problems and their precautions. Some measuring procedures are also discussed to help users locate the cause of an abnormal backlash.

## A2 The Cause and Precautions of Ballscrew Problems

Three major categories of ballscrew problems and their precautions are discussed as follows.

### A2-1 Too much play

#### 1. No preload or insufficient preload :

The ball nut will rotate and move downward by its own weight when a non-preloaded ballscrew is held vertically with the screw spindle constrained. A significant backlash may exist in a non-preloaded ballscrew unit. Therefore non-preload ballscrews are only used in the machinery, where low operation resistance but not positioning accuracy is the major concerned.

HIWIN can determine the correct amount of preload based on different applications. We can also preset the amount of preload before shipment. Be sure to clearly specify the operation condition of your application when you order a ballscrew unit.

#### 2. Too much torsional displacement :

(1) Incorrect heat treatment, hardened layer too thin, non-homogeneous hardness distribution, or material too soft:

Standard hardness of steel balls, ball nuts, and screw spindles are HRC 62-66, 58-62, and 58-62, respectively.

(2) Incorrect design-L/D ratio too high, etc:

The lower the L/D (length/diameter) ratio, the more rigid the spindle is. L/D ratio should be limited to under 60.

(The accuracy grade related to this L/D range is shown in Table 4.10) There will be a significant deflection (torsional displacement )

if the L/D ratio is too high. The ballscrew installation shown in Fig A-1

is supported at one end only. This kind of "non-rigid" design should be avoided if possible.

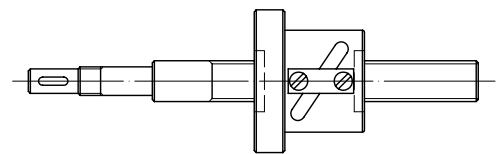

Fig. A-1 The installation of ballscrews.

#### 3. Inappropriate bearing selection :

Angular ball bearings should be used in ballscrew installation. A ball bearing with high pressure angle specially designed for ballscrew installation is even a better choice. A regular deep groove ball bearing will generate a significant amount of axial play when axially loaded. It should not be used in this application.

#### 4. Inappropriate bearing installation :

(1) If the bearing is not attached to the screw spindle properly, it would cause axial play under load. This problem may be caused by the bearing journal of the screw spindle being too long or the non-threaded part of the screw spindle being too short.

- (2) The perpendicularity between the bearing seating face and the thread axis of the bearing locknut on the ballscrew, or the parallelism between the opposite faces of the locknut is out of tolerance causing the bearing to tilt. The thread for bearing lock nut and the seating face of a bearing in the ballscrew journal should be machined in one setting to ensure the perpendicularity. It is even better if they can be ground.
- (3) Two lock nuts and a spring washer should be used in the bearing installation to prevent them from getting loose in operation.

**5. The ball nut housing or the bearing housing is not rigid enough :**

The ball-nut-mounted housing or the bearing-mounted housing may deflect under components' weight or machining load if it is not rigid enough. The test illustrated in Fig A-4 (d) can be used to check the rigidity of the ball-nut-mounted housing. Similar test can be used to check the rigidity of the bearing-mounted housing.

**6. The ball nut housing or the bearing housing is not mounted properly :**

- (1) Components may become loose due to vibration or lack of locating pin(s). Solid pins instead of spring pins should be used for locating purpose.
- (2) Ball-nut-seated screws are not seated firmly because the screws are too long or the thread holes on housing are too short.
- (3) Ball-nut-seated screws become loose due to vibration and lack of a spring washer.

**7. Parallelism or flatness of the housing surface is out of tolerance :**

In a machine assembly, a shim bar is frequently located between the housing location surface and the machine body for adjustment purpose. The clearance of table movement may vary at different locations if the parallelism or flatness of any matching component is out of tolerance no matter they are ground or scraped.

**8. The motor and the ballscrew spindle are not assembled properly :**

- (1) There will be a relative rotation between the motor shaft and the ballscrew spindle if the connecting coupling is not installed firmly or the coupling itself is not rigid enough.
- (2) Driving gears are not engaged properly or driving mechanism is not rigid. A timing belt should be used to prevent slipping if the ballscrew is to be driven by a belt.
- (3) Key is loose in the groove. Any inappropriate match among the hub, key, and key seat may cause these components to generate backlash.

## **A2-2 Unsmooth operation**

**1. Defects from ballscrew manufacturing :**

- (1) The track surface of the ballscrew spindle or the ball nut is too rough.
- (2) The roundness of the bearing balls, the ball nut or the ballscrew spindle is out of tolerance.
- (3) The lead or the pitch circle diameter of the ball nut / the spindle is out of tolerance.
- (4) The return tube is not attached to the ball nut appropriately.
- (5) Uneven bearing ball size or hardness. The above problems should not be found in the manufacturers of top quality.

**2. Foreign objects enter the ball path :**

- (1) Packing material is trapped in the ball path. Various materials and anti-rust paper are normally used to pack ballscrew units for shipment. It is possible to have these foreign materials or other objects trapped in the ball path if proper procedures are not done while installing or aligning the ballscrew unit. This may cause the bearing balls to slide instead of rolling or even cause the ball nut to jam up completely.
- (2) Machined chips get in the ball track. The chips or dust generated during machining processes may be trapped in the bearing ball track if wiper kits are not used to keep them away from the surface of the ballscrew unit. This may cause unsmooth operation, deteriorate accuracy and reduce service life.

### 3. Over-travel :

Over-travel can damage the return tube and cause it to collapse or even break. When this happens, the bearing balls will not circulate smoothly. They may break and damage the groove on the ball nut or the ballscrew spindle under severe circumstances. Over-travel may happen during set-up or as the result of a limit switch failure or a machine collision. To prevent further damage, an over-traveled ballscrew should be checked or repaired by the manufacturer before it goes back to service.

### 4. Damaged return tube:

The return tube may collapse and cause the same problems as mentioned above if it is hit heavily during installation.

### 5. Misalignment:

Radial load exists if the center line of the ball nut's housing and the screw spindle's bearing support housing are not aligned properly. The ballscrew unit may bend if this misalignment is too big. An abnormal wear may still happen even if the misalignment is not significant enough to cause a noticeable bending. The accuracy of a ballscrew unit will deteriorate rapidly if it is misaligned. The higher the preload is set in the nut, the more demanding the alignment accuracy is required in the ballscrew.

### 6. The ball nut is not mounted properly on the nut housing:

Eccentric load exists when the mounted ball nut is tilted or misaligned. If this is the case, the motor current may fluctuate during rotation.

### 7. Ballscrew unit is damaged during transportation

## A2-3 Fracture

### 1. Broken bearing ball :

Cr-Mo steel is the most commonly used material for bearing balls. It takes about 1,400kg (3,080LB) to 1,600kg (3,520LB) to break a steel ball of 3.175 mm (1/8 in) diameter. The temperature of an under-lubricated or non-lubricated ballscrew raises substantially during operation. This temperature raise could make the bearing balls brittle or break which cause damage to the grooves of the ball nut or the ballscrew spindle consequently.

Therefore, lubricant replenishment should be considered during the design process. If an automatic lubricating system is not available, a periodical grease replenishment should be scheduled as part of maintenance program.

### 2. Collapsed or broken return tube :

Over-travel of the ball nut or an impact on the return tube could cause the return tube to collapse or break. This may block the path of bearing balls and cause them to slide instead of rolling and break eventually.

### 3. Ballscrew spindle end breaks :

- (1) Inappropriate design: Sharp corners on the ballscrew spindle should be avoided to reduce local stress concentration. (Fig. A2) shows some of the appropriate screw end designs.
- (2) Bend of screw spindle journal: The seating surface of the bearing of the ballscrew and the thread axis of the bearing's lock nut are not perpendicular to each other or the opposite sides of the lock nut are not parallel to each other. This will cause the end of screw spindle to bend and eventually break. The amount of deflection at the end of the ballscrew spindle (Fig A-3) before and after the bearing's lock nut being tightened should not exceed 0.01 mm (0.0004 in).
- (3) Radial force or fluctuating stress: Misalignment in the ballscrew installation creates abnormal fluctuating shear stress and causes the ballscrew to fail prematurely.

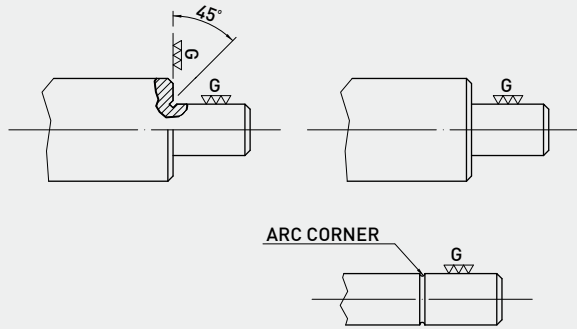

Fig A-2 The design of ballscrew spindle end

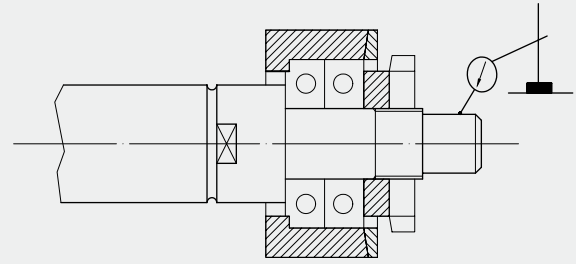

Fig A-3 The Deflection of Ballscrew Spindle

### A3 Locating the Cause of an Abnormal Backlash

The following measurement procedures can be performed to locate the cause of an abnormal backlash in the ballscrew installation.

1. Glue a gauge ball in the center hole at one end of the screw spindle. Use the flat plate of a dial indicator to check the axial movement of this gauge ball in axial direction while rotating the screw spindle (Fig A-4(a)). The movement should not exceed 0.003mm (0.00012 in), if the bearing hub, the ball nut, and the ball nut housing are all installed properly.
2. Use a dial indicator to check the relative movement between the bearing housing and the bearing seat while rotating the ballscrew (Fig A-4(b)). Any dial indicator reading other than zero indicates that either the bearing hub is not rigid enough or it is not installed properly.
3. Check the relative movement between the machine table and the ball nut housing (Fig A-4(c)).
4. Check the relative movement between the ball nut housing and the ball nut flange (Fig A-4(d)).

Contact the ballscrew manufacturer if an unsatisfactory backlash still exists while all the above checks are ok. The preload or the rigidity of the ballscrew may have to be increased.

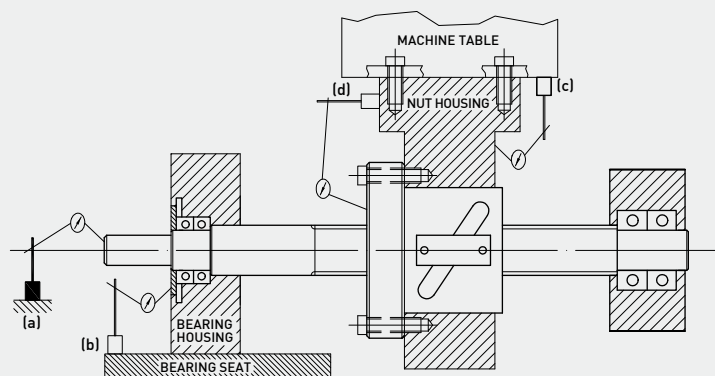

Fig. A-4 Locating the Cause of an Abnormal Backlash

# B Standard Housing Dimension Tolerance

Unit:  $\mu\text{m}=0.001\text{mm}$

Dimensional range (mm)		Dimensional range (mm)											Dimensional range (mm)																				
Over	Incl.	E10	E11	E			F			G			H			Js		J		K		M		N		P		R		Over	Incl.		
3	6	+68 +20	+95 +20	+18 +10	+22 +10	+28 +10	+28 +10	+4 +4	+16 +4	+12 +4	+18 +0	+30 +0	+48 +0	$\pm 4$	$\pm 6$	+5 -3	+6 -6	+3 -9	+2 -6	+6 -6	+2 -6	+5 -9	-1 -12	0 -12	-4 -16	-8 -20	-7 -17	-11 -23	-12 -20	-11 -23	3	6	
6	10	+83 +25	+115 +25	+22 +13	+28 +13	+35 +13	+35 +13	+14 +5	+20 +5	+9 +5	+15 +0	+22 +0	+36 +0	$\pm 4.5$	$\pm 7.5$	+5 -4	+8 -7	+5 -10	+2 -7	+5 -10	+2 -7	-3 -12	0 -15	-4 -19	-4 -16	-9 -24	-12 -21	-16 -28	-13 -25	-16 -28	6	10	
10	14	+102 +32	+142 +32	+27 +16	+34 +16	+43 +16	+43 +16	+17 +6	+24 +6	+8 +0	+11 +0	+18 +0	+27 +0	+43 +0	$\pm 5.5$	$\pm 9$	+6 -5	+10 -8	+6 -12	+2 -9	+6 -12	+2 -9	-4 -15	0 -18	-5 -20	-5 -23	-11 -29	-15 -26	-16 -24	-11 -24	-16 -24	10	14
14	18	+124 +40	+170 +40	+33 +20	+41 +20	+53 +20	+53 +20	+20 +7	+29 +7	+9 +7	+13 +0	+21 +0	+33 +0	+52 +0	$\pm 6.5$	$\pm 10.5$	+8 -5	+12 -9	+6 -15	+2 -11	+6 -15	+2 -11	-4 -17	0 -21	-11 -24	-7 -28	-14 -35	-18 -31	-24 -37	-24 -41	-24 -41	14	18
18	24	+150 +50	+210 +50	+41 +25	+50 +25	+64 +25	+64 +25	+25 +9	+34 +9	+11 +0	+16 +0	+25 +0	+39 +0	+62 +0	$\pm 8$	$\pm 12.5$	+10 -6	+14 -11	+7 -13	+3 -13	+7 -13	+3 -13	-4 -20	0 -25	-8 -28	-8 -33	-17 -42	-21 -37	-25 -45	-25 -50	-25 -50	18	24
24	30	+180 +60	+250 +60	+49 +30	+60 +30	+76 +30	+76 +30	+29 +10	+40 +10	+13 +10	+19 +0	+30 +0	+46 +0	+74 +0	$\pm 9.5$	$\pm 15$	+13 -6	+18 -12	+4 -15	+4 -15	+4 -15	+4 -15	-5 -24	0 -30	-14 -33	-14 -39	-21 -51	-26 -45	-26 -51	-26 -51	-26 -51	24	30
30	40	+212 +72	+292 +72	+58 +36	+71 +36	+90 +36	+90 +36	+34 +12	+47 +12	+15 +0	+22 +0	+35 +0	+54 +0	+87 +0	$\pm 11$	$\pm 17.5$	+16 -6	+22 -13	+4 -18	+4 -18	+4 -18	+4 -18	-6 -35	0 -40	-16 -38	-16 -45	-24 -59	-30 -52	-30 -52	-30 -52	-30 -52	30	40
40	50	+245 +85	+335 +85	+68 +43	+83 +43	+106 +43	+106 +43	+39 +14	+54 +14	+18 +0	+25 +0	+40 +0	+63 +0	+100 +0	$\pm 12.5$	$\pm 20$	+18 -7	+26 -14	+4 -21	+4 -21	+4 -21	+4 -21	-8 -33	0 -40	-20 -45	-20 -52	-28 -68	-36 -61	-36 -61	-36 -61	-36 -61	40	50
50	65	+285 +100	+390 +100	+89 +50	+96 +50	+122 +50	+122 +50	+44 +15	+61 +15	+20 +0	+29 +0	+46 +0	+72 +0	+115 +0	$\pm 14.5$	$\pm 23$	+22 -7	+30 -16	+5 -24	+5 -24	+5 -24	+5 -24	-8 -37	0 -40	-22 -51	-22 -60	-33 -79	-41 -70	-41 -70	-41 -70	-41 -70	50	65
65	80	+390 +100	+500 +100	+100 +50	+110 +50	+140 +50	+140 +50	+50 +20	+70 +20	+30 +0	+40 +0	+60 +0	+90 +0	+120 +0	$\pm 15$	$\pm 25$	+25 -10	+35 -20	+5 -20	+5 -20	+5 -20	+5 -20	-10 -30	-20 -40	-30 -50	-30 -60	-40 -80	-45 -85	-45 -85	-45 -85	-45 -85	65	80
80	100	+490 +120	+650 +120	+120 +60	+130 +60	+170 +60	+170 +60	+60 +30	+80 +30	+40 +0	+50 +0	+70 +0	+100 +0	+130 +0	$\pm 17.5$	$\pm 30$	+30 -15	+40 -20	+10 -30	+10 -30	+10 -30	+10 -30	-20 -50	-30 -60	-40 -70	-40 -80	-50 -100	-55 -110	-55 -110	-55 -110	-55 -110	80	100
100	120	+590 +140	+800 +140	+140 +70	+150 +70	+200 +70	+200 +70	+70 +40	+90 +40	+50 +0	+60 +0	+80 +0	+110 +0	+140 +0	$\pm 20$	$\pm 35$	+40 -20	+50 -30	+20 -40	+20 -40	+20 -40	+20 -40	-30 -60	-40 -70	-50 -80	-50 -90	-60 -120	-65 -125	-65 -125	-65 -125	-65 -125	100	120
120	140	+690 +160	+950 +160	+160 +80	+170 +80	+230 +80	+230 +80	+80 +50	+100 +50	+60 +0	+70 +0	+90 +0	+120 +0	+150 +0	$\pm 25$	$\pm 45$	+50 -30	+60 -40	+30 -50	+30 -50	+30 -50	+30 -50	-40 -80	-50 -90	-60 -100	-60 -110	-70 -140	-75 -145	-75 -145	-75 -145	-75 -145	120	140
140	160	+790 +180	+1100 +180	+180 +90	+190 +90	+260 +90	+260 +90	+90 +60	+120 +60	+70 +0	+80 +0	+100 +0	+130 +0	+160 +0	$\pm 30$	$\pm 55$	+60 -40	+70 -50	+40 -60	+40 -60	+40 -60	+40 -60	-50 -90	-60 -100	-70 -110	-70 -120	-80 -160	-85 -165	-85 -165	-85 -165	-85 -165	140	160
160	180	+890 +200	+1250 +200	+190 +100	+200 +100	+280 +100	+280 +100	+100 +70	+130 +70	+80 +0	+90 +0	+110 +0	+140 +0	+170 +0	$\pm 35$	$\pm 65$	+70 -50	+80 -60	+50 -70	+50 -70	+50 -70	+50 -70	-60 -100	-70 -110	-80 -120	-80 -130	-90 -180	-95 -185	-95 -185	-95 -185	-95 -185	160	180
180	200	+990 +225	+1400 +225	+200 +110	+210 +110	+300 +110	+300 +110	+110 +80	+140 +80	+90 +0	+100 +0	+120 +0	+150 +0	+185 +0	$\pm 40$	$\pm 75$	+80 -60	+90 -70	+60 -80	+60 -80	+60 -80	+60 -80	-70 -110	-80 -120	-90 -130	-90 -140	-100 -200	-105 -205	-105 -205	-105 -205	-105 -205	180	200
200	225	+1090 +250	+1550 +250	+210 +120	+220 +120	+320 +120	+320 +120	+120 +90	+150 +90	+100 +0	+110 +0	+130 +0	+160 +0	+200 +0	$\pm 45$	$\pm 85$	+90 -70	+100 -80	+70 -90	+70 -90	+70 -90	+70 -90	-80 -120	-90 -130	-100 -140	-100 -150	-110 -210	-115 -215	-115 -215	-115 -215	-115 -215	200	225
225	250	+1190 +275	+1650 +275	+220 +130	+230 +130	+340 +130	+340 +130	+130 +100	+160 +100	+110 +0	+120 +0	+140 +0	+170 +0	+210 +0	$\pm 50$	$\pm 95$	+100 -80	+110 -90	+80 -100	+80 -100	+80 -100	+80 -100	-90 -130	-100 -140	-110 -150	-110 -160	-120 -220	-125 -225	-125 -225	-125 -225	-125 -225	225	250

# C Standard Spindle Dimension Tolerance

Unit:  $\mu\text{m}=0.001\text{mm}$

Dimensional range (mm)	Dimensional range (mm)																
	Over	Incl.	a	c	d	e	f	g	h	j	k	m	n	p	r	Over	Incl.
3	6	-270	-70	-30	-20	-10	-10	-4	-4	0	0	0	0	0	+23	+27	6
6	10	-450	-190	-38	-28	-15	-18	-9	-12	-8	-12	-18	-30	-48	+15	+15	10
10	14	-280	-80	-40	-25	-13	-13	-5	-5	0	0	0	0	0	+28	+34	10
14	18	-500	-230	-49	-34	-19	-22	-11	-14	-6	-9	-15	-22	-36	+19	+19	14
18	24	-290	-95	-50	-32	-16	-16	-6	-6	0	0	0	0	0	+34	+41	14
24	30	-560	-275	-61	-43	-20	-27	-14	-17	-8	-11	-18	-27	-43	+23	+23	18
30	40	-300	-110	-65	-40	-20	-20	-7	-7	0	0	0	0	0	+41	+49	24
40	50	-630	-320	-78	-53	-29	-33	-16	-20	-9	-13	-21	-33	-52	+28	+28	30
40	50	-310	-120	-80	-50	-25	-25	-9	-9	0	0	0	0	0	+50	+59	40
50	65	-700	-370	-96	-66	-36	-41	-20	-25	-11	-16	-25	-39	-62	+34	+34	50
50	65	-320	-130	-100	-70	-38	-40	-16	-20	-13	-19	-30	-46	-74	+60	+60	65
65	80	-340	-140	-110	-79	-43	-49	-23	-29	-13	-19	-30	-46	-74	+41	+41	65
80	100	-800	-440	-119	-79	-43	-49	-23	-29	-13	-19	-30	-46	-74	+62	+62	80
80	100	-360	-170	-120	-72	-36	-36	-12	-12	0	0	0	0	0	+43	+43	80
100	120	-820	-450	-120	-72	-36	-36	-12	-12	0	0	0	0	0	+73	+73	100
100	120	-380	-170	-120	-72	-36	-36	-12	-12	0	0	0	0	0	+51	+51	100
120	140	-920	-520	-120	-72	-36	-36	-12	-12	0	0	0	0	0	+76	+76	120
120	140	-410	-180	-142	-94	-51	-58	-27	-34	-15	-22	-35	-54	-87	+54	+54	120
140	160	-950	-530	-140	-94	-51	-58	-27	-34	-15	-22	-35	-54	-87	+88	+103	140
140	160	-460	-200	-145	-85	-43	-45	-14	-14	0	0	0	0	0	+63	+63	140
160	180	-1090	-600	-170	-110	-61	-68	-32	-39	-18	-25	-40	-63	-100	+68	+68	160
160	180	-520	-210	-170	-110	-61	-68	-32	-39	-18	-25	-40	-63	-100	+90	+105	160
160	180	-1150	-610	-170	-110	-61	-68	-32	-39	-18	-25	-40	-63	-100	+65	+65	160
180	180	-580	-230	-170	-110	-61	-68	-32	-39	-18	-25	-40	-63	-100	+93	+108	180
180	180	-1210	-630	-170	-110	-61	-68	-32	-39	-18	-25	-40	-63	-100	+68	+68	180



# D HIWIN Ballscrew Data Inquiry (A)

Company \_\_\_\_\_ Date \_\_\_\_\_  
 Address \_\_\_\_\_  
 Telephone \_\_\_\_\_ Fax. \_\_\_\_\_  
 Machine Type \_\_\_\_\_ Application \_\_\_\_\_  
 Attached Drawing Yes \_\_\_\_\_ (Drawing No. \_\_\_\_\_ ) No. \_\_\_\_\_  
 Please fill or check following items.

## 1. Load Condition

(a) Working Axial Load

Max. \_\_\_\_\_ kgf , at \_\_\_\_\_ rpm for \_\_\_\_\_ % of operation time

Normal. \_\_\_\_\_ kgf , at \_\_\_\_\_ rpm for \_\_\_\_\_ % of operation time

Min. \_\_\_\_\_ kgf , at \_\_\_\_\_ rpm for \_\_\_\_\_ % of operation time

(Total of operation time ratio should be 100%)

(b) Max. Axial Static Load \_\_\_\_\_ kgf

(c) Deviated Load, if any (Please avoid this load condition, if possible)

Radial Load \_\_\_\_\_ kgf Moment Load \_\_\_\_\_ kgf-cm

## 2. Operation Conditions

(a) Stroke \_\_\_\_\_ mm , Motor power used \_\_\_\_\_ kw

(b) Life Expectancy \_\_\_\_\_ x10<sup>6</sup> revs, \_\_\_\_\_ km, \_\_\_\_\_ hr

(c) Rotation Shaft \_\_\_\_\_ Nut \_\_\_\_\_

(d) Mounting Method \_\_\_\_\_ Mounting Span \_\_\_\_\_ mm

(e) Shock/Vibration: Smooth \_\_\_\_\_ Normal \_\_\_\_\_ Vibration \_\_\_\_\_

## 3. Main Dimensions

(a) Screw Shaft O.D. \_\_\_\_\_ mm Turning Direction: R \_\_\_\_\_ L \_\_\_\_\_

(b) Lead \_\_\_\_\_ mm (Pitch \_\_\_\_\_ mm) No. of Starts \_\_\_\_\_

(c) Total Length \_\_\_\_\_ mm Effective Threaded Length \_\_\_\_\_ mm

(d) Nut Type \_\_\_\_\_ Seal \_\_\_\_\_

(e) Support Bearing: Ball \_\_\_\_\_ Roller \_\_\_\_\_

## 4. Lead Accuracy, Axial Clearance, Preload and Stiffness

(a) Target Point of Accumulated Lead Tp: \_\_\_\_\_ mm

(b) Accuracy Grade \_\_\_\_\_ (Lead Deviation: \_\_\_\_\_ mm/300mm)

(c) Axial play \_\_\_\_\_ mm max.

(d) Preload \_\_\_\_\_ kgf (or Drag Torque \_\_\_\_\_ kgf-cm)

(e) Nut Stiffness Kn \_\_\_\_\_ kgf/ $\mu$ m

## 5. Other Conditions

(a) Lubrication: Grease \_\_\_\_\_ Oil \_\_\_\_\_

(b) Ambient Temperature \_\_\_\_\_  °C  °F

(c) Special Conditions \_\_\_\_\_

# E

## HIWIN Ballscrew Request Form (B)

### Request for quotation

Customer Name: \_\_\_\_\_ Date: \_\_\_\_\_  
 Address: \_\_\_\_\_ Phone: \_\_\_\_\_  
 \_\_\_\_\_ Country: \_\_\_\_\_  
 Desired Delivery Date: \_\_\_\_\_ Delivery Point: \_\_\_\_\_  
 Type of Ball Screw: (1) \_\_\_\_\_ Quantity: \_\_\_\_\_  
 (2) \_\_\_\_\_ Quantity: \_\_\_\_\_

### Required Specifications:

- (1)  Single Start  Double Start  Triple Start  Four Start
  - (2) Direction of Turn:  Right  Left
  - (3) Shaft Diameter: \_\_\_\_\_
  - (4) Lead: \_\_\_\_\_
  - (5) Circuit: \_\_\_\_\_
  - (6) Nut Type: \_\_\_\_\_
  - (7)  Internal  External  Endcap
  - (8) Thread Length: \_\_\_\_\_
  - (9) Overall Length: \_\_\_\_\_
  - (10) Accuracy Grade: \_\_\_\_\_  
 (Lead Deviation: \_\_\_\_\_ mm/300mm)
  - (11) Speed: \_\_\_\_\_ rpm
  - (12)  Rolled  Ground
- \* Please refer to HIWIN catalog P.36 for nut information.

Customer Special Requirement

● Please answer the following questions.

Your kind answers would be very helpful in preparing quotation promptly.

- (a) In what kind of application is this ballscrew used ?
- (b) Is this ballscrew used for the X, Y, or Z axis? Vertically or horizontally ?
- (c) How many ballscrews are needed for each machine and what is the annual requirement ?
- (d) If this is not a new project, whose ballscrews are you using currently ?

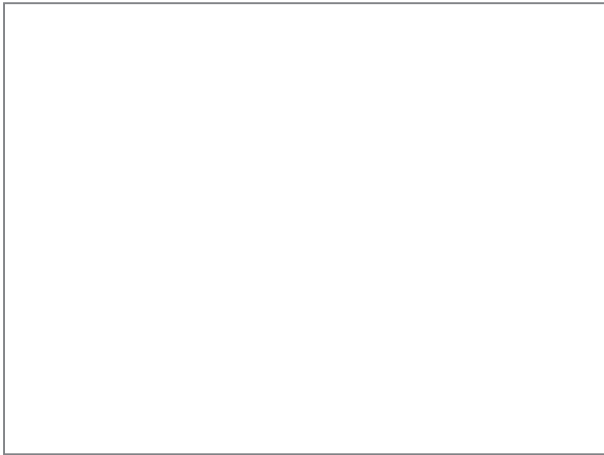

## HIWIN TECHNOLOGIES CORP.

No. 46, 37th Road,  
Taichung Industrial Park  
Taichung 40768, TAIWAN  
Tel: +886-4-23594510  
Fax: +886-4-23594420  
www.hiwin.com.tw  
business@mail.hiwin.com.tw

## HIWIN USA

•CHICAGO  
1400 Madeline Lane  
Elgin, IL 60124, U.S.A.  
Tel : +1-847-8272270  
Fax: +1-847-8272291  
www.hiwin.com  
info@hiwin.com

## •SILICON VALLEY

Tel : +1-510-4380871  
Fax: +1-510-4380873

## HIWIN JAPAN

•KOBE  
3F. Sannomiya-Chuo Bldg.  
4-2-20 Goko-Dori, Chuo-Ku  
KOBE 651-0087, JAPAN  
Tel: +81-78-2625413  
Fax: +81-78-2625686  
www.hiwin.co.jp  
info@hiwin.co.jp

## HIWIN GmbH

Brücklesbünd 2, D-77654  
Offenburg, GERMANY  
Tel : +49-781-93278-0  
Fax: +49-781-93278-90  
www.hiwin.de  
www.hiwin.eu  
info@hiwin.de

## HIWIN SCHWEIZ

Schachenstrasse 80  
CH-8645 Jona,  
SWITZERLAND  
Tel : +41-55-2250025  
Fax: +41-55-2250020  
www.hiwin.ch  
info@hiwin.ch

## HIWIN S.R.O.

Kastanova 34  
CZ 62000 Brno,  
CZECH REPUBLIC  
Tel : +420-548-528238  
Fax: +420-548-220233  
www.hiwin.cz  
info@hiwin.cz

## HIWIN FRANCE

24 ZI N 1 EST-BP 78  
F-61302 L'Aigle Cedex  
Tel : +33(0)233341115  
Fax: +33(0)233347379  
www.hiwin.fr  
info@hiwin.fr

## Mega-Fabs Motion Systems, Ltd.

13 Hayetzira St. Industrial Park,  
P.O.Box 540, Yokneam 20692, Israel  
Tel : +972-4-9891050  
Fax: +972-4-9891080  
www.mega-fabs.com  
mega-f@mega-f.co.il