

Using Material of High Quality

CPS CABLECHAIN[®]

MINI-Type / Sliding-Type

RoHS

RoHS Directive 2002/95/EC
(유해물질 사용제한지침)

Raw materials for CPS Cablechain are 100% RoHS
and have passed the test by designated test methods.
In addition, CPS products have been produced
according to the directive that Europe requires.

CPS Cablechain의 사용재료는 유럽시장이에 시험을 통과
한 100%의 무해성으로, 유럽에서 규정한 유해물질 사용
제한 지침에 따라 생산되고 있습니다.



CPS CABLECHAIN[®]

Are made of polyamide6 with glass fiber, bearing up
against low temperature and any shocks.

The chains are using single-pin type so that chains
hardly separate from each link, using for a long time with
speed.

Using Material of High Quality

• Instructions for the installation of cable

1 생산일자 표시(Marking production Date)



-케이블체인의 외관에 생산일자를 기록해서 제품의 생산시점을 알수있게 하여 소비자의 품질관리에 편리하도록 고안.

The CPS cable chain shows the production date on the outside of each link on the side band.

2 조립 및 분해가 매우 쉽게 제작(Designed to assemble and disassemble each link simply)



-특별고안된 중심핀(Pivot Pin)을 사용하여 조립, 분해 공정을 최소화하여 링크설치 및 보수시 작업공정시간이 단축 되도록 고안.

The CPS cable chains are designed with a single pivot pin, which reduces the time for both installation & repair.

3 저분진(Low-mote design)



-분진을 최소화하기 위해 마찰면이 링크레스 방식으로 개발되었음.

The CPS cable chain is especially designed to be link less with no frictional parts to minimise.

4 저소음(Low-noise design)



-소음을 최소화 하기위해 링크레스 방식으로 개발되었음.

The CPS cable chain is especially designed as link-less type with no friction parts to decrease the noise.

5 케이블체인 전품목 나일론후레임 사용 (Nylon frames for all type of cable chains)



-케이블체인에 알루미늄 봉을 사용함으로써 나타나는 케이블피복 손상을 완전 예방할 수 있으며 작동시 이탈되는 문제, 보수가 불편한점 등을 해소하기 위해 나일론 후레임을 사용함으로써 설치, 보수가 용이하고 알루미늄봉의 탈착문제도 해결할 뿐만 아니라 볼트의 마모 및 풀림현상을 방지할 수 있다.

Using Nylon frames is more convenient than aluminum rod frames. Using nylon frames eliminates the chance of rods becoming detached from the side frame, also reduces setting up time and protects against abrasion & disintegrated appearance of a bolt.

6 체인 내부공간 확대 (Expansion of interior space)

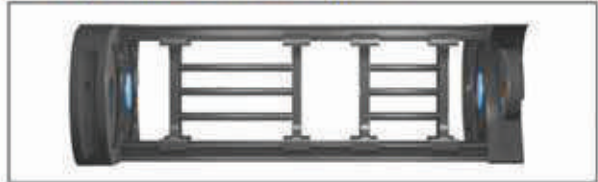

-체인의 내부높이를 크게 제작하여 Self-supporting 길이를 더 길게 사용될 수 있도록 제작하였으며 내부공간의 여유 및 폭을 확대하였음.

The CPS cable chains are designed to expand inner height in order to use longer self supporting length.

7 1핀 연결방식 (One pivot pin connection)

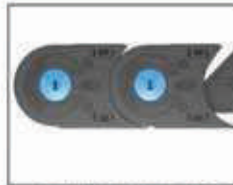

-링크연결방식을 3핀방식의 단점인 체인에 하중을 가했을시 마모로 인해 처지는 현상이 발생하여 체인이 파손되고 내부케이블에 손상을 받는 현상을 1핀방식으로 교체하여 곡률반경을 형성하는 링크를 한 방향으로 지지할 수 있도록 함으로써 결합성을 높일뿐만 아니라

강한 힘에도 견딜 수 있고 처지는 현상을 완전히 예방할 수 있는 제품을 개발함.

Link connecting style has been changed three pin type to one pin type. In case of three pin type, the cable chains were hung down and got a damage both the cable chains and cables inside when the chains overloaded. Since one pin type takes each link's course to same direction, that makes chains are raising the cohesion and it can bear a strong shock from the outside as well as overcome hanging down. Also this type of pin is easily assembled and disassembled with a simple tool.

8 링크결합 방식 (Poke Pin style for Link connecting)



-기존의 케이블체인은 대부분 링크연결방식(Half in out, 2중결합)이나, CPS케이블체인은 Poke Pin방식(3중결합)으로 왕복운동으로 인하여 좌우로 비틀렸을 경우 케이블체인에 링크 이탈현상이 발생되지 않으며 빠른속도에도 견딜수있어서 수명이 오래가는 장점이 있음.

Link connecting style(half in out) is widely used. However, CPS cable chain selects Poke Pin connecting style, since there is no come off each link when get twisted. By this reason, CPS cable chain keep up its life time longer than other brand chains and have a reputation for the quality from many engineers in Hyundai Motors, Kia Motors and Daewoo Motors.

Using Material of High Quality

• Instructions for the installation of cable

9 슬라이드타입 체인-스키드 분해,조립간단 (Slide type- skid).



-슬라이드제품에 사용되는 스키드를 드라이버 하나로 조립, 분해가 가능하게 개발하여 수리시간을 1/10배로 단축시켰으며 또한 스키드바닥면에 요철방식을 주어 마찰계수를 줄임.

CPS developed new type of skid for slide type cable chains. This skid can be assembled with a screwdriver very simply, so that can reduce time for repair as well as reduce the coefficient of friction, giving a unevenness method to the bottom of skid.

10 일체형 브라켓 (End Bracket- One united body style).



-체인의 많은 작동으로 인해 볼트가 풀리는 문제점이 발생하여 브라켓이 이탈되는 현상이 자주 발생하여서 이를 개선한 일체형 브라켓을 사용함으로써 체인과 연결 사용시 볼트를 이용해서 브라켓을 연결하는 것보다 견고하고 안정적으로 작동되게 개발되었다. 또한 브라켓을 체인에 고정하지 않고 끼워 놓는 스타일은 체인이동시 체인과 브라켓이 이탈하는 문제점이 발생되고 있으나 CPS일체형브라켓만이 이런 문제점을 완전히 해결하였다.

CPS end breakets designed one united body style, so it's more stable and stronger than connecting with bolt. Sometimes, customers use the end bracket which is inserted, not fixed with the cable chain. In this case, it can be found the bracket come off from the side band. Only CPS end bracket solve these all problems.

11 Separator의 다양화 실현 (Various kind of Separators).

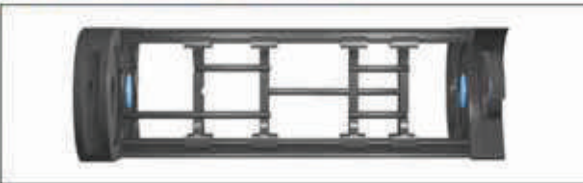

-케이블, 호스의 체인내부 설치시 2단 ~8단형으로 자유자재로 분리될수 있는 Separator를 최소 3칸에서 9칸까지 자유롭게 설치할수 있게 제작함으로써 내부케이블 또는 호스간의 상호간섭을 줄여 사용에 안전성을 구현하였다.

In order to install multipule cables, hoses with different diameter inside of the chain, seperators can be used to create variatble sized compartments to accomadate your particular cable, hose requirements.

12 스토퍼 적용 (Stoper).



-체인내부에 설치되는 디바이더의 위치를 조정하고 고정하는 역할로 케이블의 크기에 따른 디바이더의 위치조정시 후레임에 필요한 수량만큼 결합하여 사용할수 있다.

This item control the position of divider and fixing the location, it can be applied to the frame accordingly by the width.

13 Easy 브라켓 (Easy End Bracket).

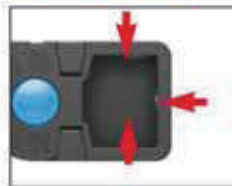

-CPS의 Easy브라켓은 위쪽,아래쪽,앞쪽 등 다양한 방향으로 고정할 수 있도록 제작되어 기존브라켓의 방향이 맞지 않았을때 발생될수 있는 문제점을 완벽하게 해결하였다.

The Easy Bracket of CPS can be fixed on all directions such as up, down & side.

14 Tiewrap 브라켓 (Tiewrap end bracket).

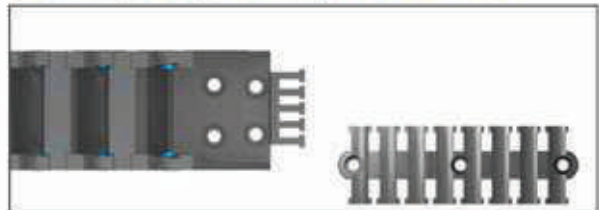

-브라켓의 이동부위와 고정부위에 케이블, 호스를 고정하기 위해 개발된 타이랩은 소형제품에는 브라켓과 결합되어 있고 큰제품에는 분리되어(케이블외경의 20~30배 후방에 고정)있다. 이 제품에는 케이블, 호스의 손상을 방지하고 각 케이블마다 가지런히 배열하여 고정할 수 있으며 체인 내부에서 케이블, 호스가 엉키는 현상을 방지할 수 있다.

Tiewrap type end bracket developed in order to fix the cables, hoses on the bracket of each moving point and fixing point. Tiewrap is combined with end bracket for small size cable chain. In case of big size cable chain, the tiewrap is separated from its end bracket, since the cables or hoses have to be fixed into a distance of about 20~30x outer diameter of cable backward. This method well as prevents cables inside of chain get tangled.

Using Material of High Quality

Chain Request for selecting sorts (체인사양 선정방법)

➔ Selecting criterion for cable chain (케이블체인 선정기준)

1. STROKE(total traveling distance of the equipment): 장비의 총 이동거리

Judge whether chain for selecting droops or not.

선정될 체인이 이동거리에서 처지는지의 여부를 판단한다.

2. Bending Radius(곡률반경) R

Rotation diameter of chain must be bigger than the biggest one of cables or hoses to be in the cable chain.

케이블체인에 들어갈 전선이나 호스의 제일 큰 회전반경보다 체인의 회전반경이 더 커야한다. 회전반경이 작을 시 굴곡에 대한 반발과 마찰이 생겨 전선이나 케이블에 손상을 준다.

곡률반경 구하는 값은 체인에 입선될 케이블혹은 호스중 직경이 가장큰것의 8~20배로 계산한다.

R min > 8~10 × Cable outer diameter

케이블(전선)사용시 : 직경의 8~10배

R min > 15~20 × Hose outer diameter

호스 사용시 : 직경의 15~20배

3. Internal size of chain (체인의 내부사이즈)

Select sorts of chain by checking inserted cable q'ty and diameter.

Select the internal size of chain after selecting 1,2

체인의 입선되는 전선의 가닥수와 지름을 체크하여 사양을 선정한다.

위의 1번, 2번 항이 선정된 후에 체인의 내부사이즈를 선정한다.

4. The length of chain (체인길이)

Must select the length of chain by checking the starting point of chain when traveling.

체인이 이동되는 시작포인트를 체크하여 길이를 산정해야 한다.

➔ Calculation of the length for chain (케이블체인 길이 산정 방법)

$$L = LS/2 + LP \quad (LP = \pi \times R + 4P)$$

L : The length of chain (체인의 길이)

LS/2: The half of total stroke (총 Stroke의 절반)

LS: Total stroke, total traveling distance of the equipment (총 Stroke, 총 장비이동거리)

LP: Loop length (체인의 곡률길이)

P: Length of each pitch (체인의 1링크길이)

π : 3.14

R: Bending radius of chain (체인의 곡률반경)

➔ Calculation of the height of installation for chain (케이블체인 설치높이(H) 산정 방법)

$$H = 2R + B$$

H: Length of the upper end & lower end for chain when forming round (Round 형성시 체인 상부끝과 하부끝의 총 길이)

R: Bending radius of chain (체인 곡률반경) B: The height for outer width for chain (체인의 외폭높이)

체인설치시 적정 높이: H + @ @: 체인사양에 따라 변동 (ex. CPS068N, CPS077N은 +40mm)

Proper height of installing chain: H + @ @: It depends on the sort of chain(ex. CPS068N,077N =+40mm)

➔ Calculation of the bending radius for cable chain (설치된 케이블체인 곡률반경 산정 방법)

$$R = (H - B)/2$$

Firstly checking the total height of chain, and then subtract the height of outer height from it, Finally divide it by 2.

체인의 전체높이를 체크한 뒤 체인 외폭높이를 뺀후 2로 나눈 값이 체인의 곡률반경값이다.

Using Material of High Quality

Tiewrap System

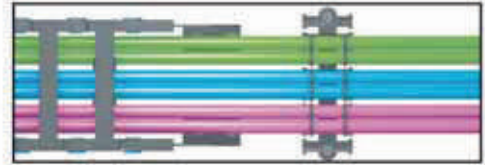

Tiewrap System (케이블 고정 시스템)

The cables and hoses should be fixed a backward from 30mm X maximum diameter of cable or hose in moving point so as to block up cutting the cables or hoses when move cable chain.

Tiewrap system is a valuable tool for fixing the cables or hoses which installed in the cable chain.

케이블 또는 호스는 브라켓의 Moving point 부분에서 케이블 직경의 30배 후방에 설치함으로써 체인의 움직임으로 인해 체인내의 케이블이나 호스가 팽팽히 당겨져 단선되는 경우를 방지할 수 있다.

CPS의 Tiewrap은 케이블체인의 브라켓 부분과 근접해서 사용할 수 있는 편리한 구성품으로 015, 020, 030, 033, 036, 050 타입의 체인의 경우에는 타이랩이 부착된 브라켓을 사용할 수 있으며 068, 077, 095, 120 타입의 체인은 브라켓과 별도의 고정용 타이랩을 사용한다.

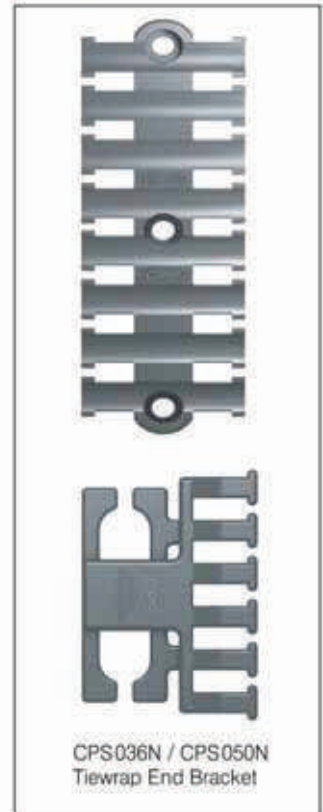
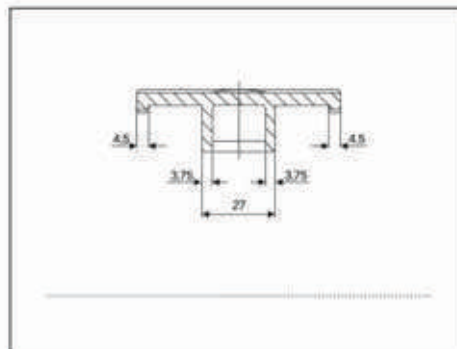
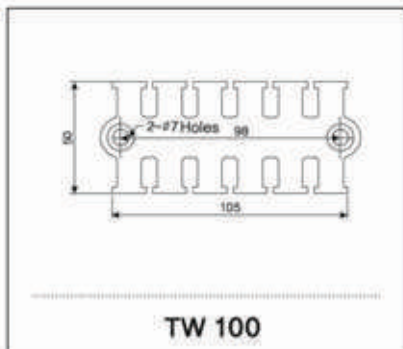
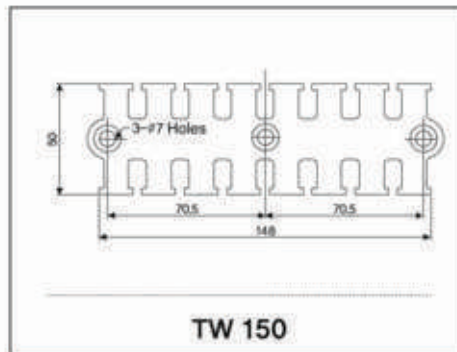
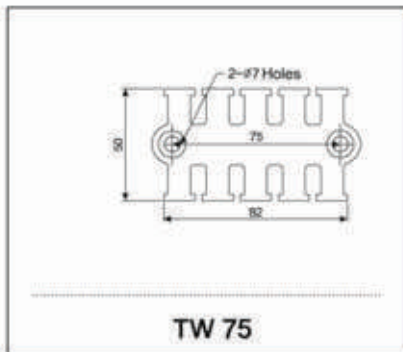
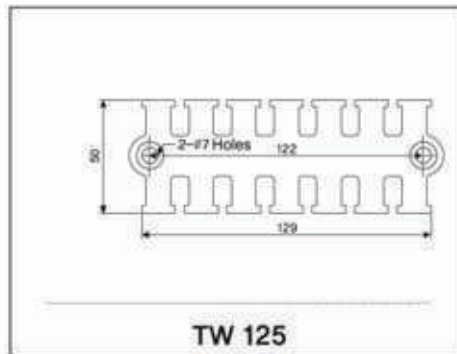
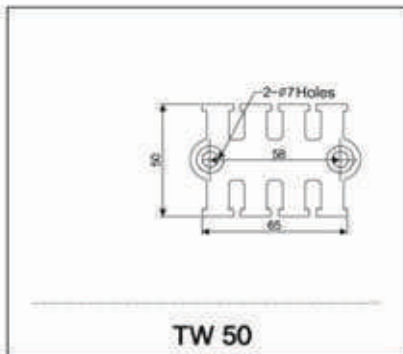

Using Material of High Quality

Stoper System

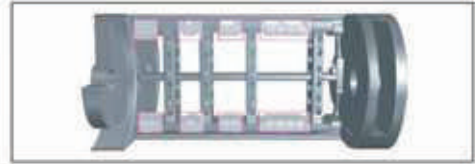

Stoper System (디바이더 고정 시스템)

Stoper fixing the location of divider which is settled in side of cable chain and control the position of divider by the inserted cable's size and quantity.

The items are classified as ST-M1, ST-M2, ST-S1, ST-S2 and please refer following drawings.

스토퍼는 체인내부에 설치되는 디바이더의 위치를 조정하고 고정하는 역할을 한다.

체인에 입선되는 케이블의 크기와 수량에 따른 디바이더의 위치조정 시 사용하며, 후레임에 필요한 수량만큼 스토퍼를 결합하여 디바이더의 위치를 고정시켜 디바이더의 풀림현상에 따른 케이블과의 마찰을 방지하는 역할을 한다.

세부사양으로는 ST-M1, ST-M2와 ST-S1, ST-S2로 구분하여 사용하며 세부사양에 따른 적용가능 체인은 아래를 참조한다.

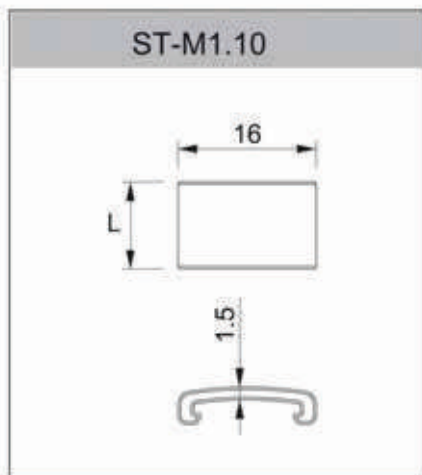

ST-M1.10: CPS 036N

ST-M2.10: CPS 050N

(L: 5, 10, 15, 20)

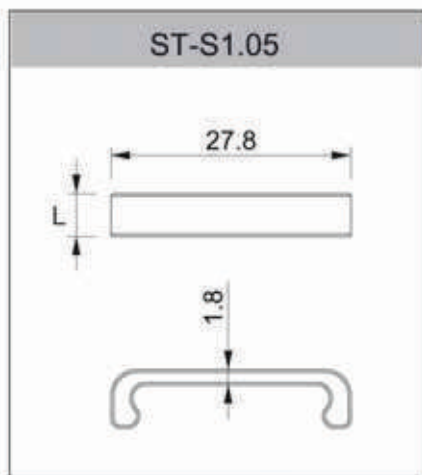
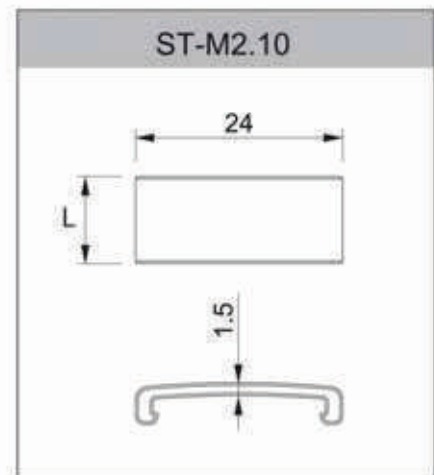

ST-S1.05: CPS 068,077

ST-S2.05: CPS 095,120

(L: 5, 10, 15, 20)

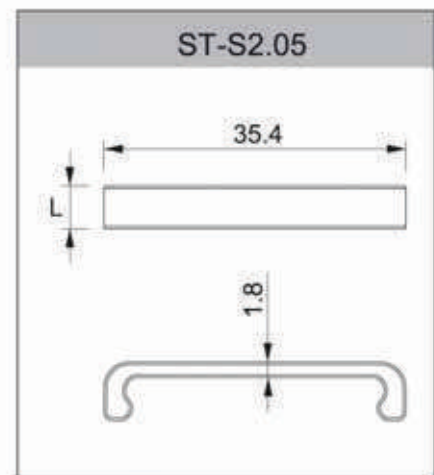

Using Material of High Quality

CPS Cable Chain MINI-Type	Pitch	Bending Radius R 	Weight kg/m	Speed m/sec	Temperature °C	Clearance 				Frame style	Divider possible with frame
						A	B	C	D		
CPS015.06	15	18,28,38	0.100	10	-30 ~ +130	12.6	13	6	10		
CPS015.10	15		0.106			16.6	13	10	10		
CPS015.15	15		0.111			21.6	13	15	10		
CPS015.20	15		0.115			26.6	13	20	10		
CPS020.15	20	28,38,48	0.24	10	-30 ~ +130	24	20	15	14.5		
CPS020.20	20		0.26			29	20	20	14.5		
CPS020.30	20		0.28			39	20	30	14.5		
CPS020.40	20		0.31			49	20	40	14.5		
CPS030.15	30	38,48, 75, 100	0.38	10	-30 ~ +130	29	26	15	19		
CPS030.25	30		0.40			39	26	25	19		
CPS030.35	30		0.42			49	26	35	19		
CPS030.50	30		0.44			64	26	50	19		
CPS033.27	33	35,45,75, 100,120	0.55	10	-30 ~ +130	45	31	27	23		
CPS033.37	33		0.59			55	31	37	23		
CPS033.47	33		0.61			65	31	47	23		
CPS033.67	33		0.68			85	31	67	23		
CPS033.77	33		0.70			95	31	77	23		
Medium-Type	Pitch	Bending Radius R	Weight	Speed	Temperature	Clearance				Frame style	Divider possible with frame
CPS036.035	36	70,90,120,150	1.21	10	-30 ~ +130	59	38	35	27		
CPS036.055	36		1.29			79	38	55	27		
CPS036.075	36		1.39			99	38	75	27		
CPS036.100	36		1.50			124	38	100	27		
CPS050.050	50	100,125,150,200	1.98	10	-30 ~ +130	78	52	50	38		
CPS050.075	50		2.22			103	52	75	38		
CPS050.100	50		2.44			128	52	100	38		
CPS050.125	50		2.59			153	52	125	38		
CPS050.150	50		2.93			178	52	150	38		
CPS036N.035	36	50,70,90, 120,150	1.18	10	-30 ~ +130	59	38	35	28		
CPS036N.055	36		1.21			79	38	55	28		
CPS036N.075	36		1.29			99	38	75	28		
CPS036N.100	36		1.40			124	38	100	28		
CPS036N.125	36		1.47			149	38	125	28		
CPS050N.050	50	75,100,125, 150,200	1.86	10	-30 ~ +130	78	52	50	40		
CPS050N.075	50		1.98			103	52	75	40		
CPS050N.100	50		2.10			128	52	100	40		
CPS050N.110	50		2.16			138	52	110	40		
CPS050N.125	50		2.28			153	52	125	40		
CPS050N.150	50		2.36			178	52	150	40		
CPS050N.175	50		2.50			203	52	175	40		
CPS050N.200	50		2.58			228	52	200	40		

Using Material of High Quality

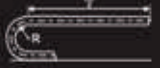
CPS Cable Chain System – Type	Pitch	Bending Radius R 	Weight kg/m	Speed m/sec	Temperature °C	Clearance 				Frame style	Divider possible with frame
						A	B	C	D		
CPS068N	68	75,100,150,200,250,300	3.57	10	-30 ~ +130	80-430	60	50-400	40		
CPS077N	77	100,120,140,200,250,300	3.72			80-430	70	50-400	50		
CPS095N	95	135,150,200,230,280,400	5.29			115-440	82	75-400	54		
CPS120N	120	180,200,250,300,350,400,500	5.68			115-440	108	75-400	80		
Medium – Type	Pitch	Bending Radius R	Weight	Speed	Temperature	Clearance				Frame style	Divider possible with frame
CPS036S.035	36	70,90,120,150	1.25	10	-30 ~ +130	67	41	35	28		
CPS036S.055	36		87			41	55	28			
CPS036S.075	36		107			41	75	28			
CPS036S.100	36		132			41	100	28			
CPS068S	68	100,150,200,250,300	3.89	10	-30 ~ +130	96-446	65	50-400	40		
CPS077S	77	120,140,200,250,300	4.11			96-446	75	50-400	50		
CPS095S	95	135,150,200,230,280,400	5.81			129-454	89	75-400	54		
CPS120S	120	180,200,250,300,350,400,500	6.26			129-454	115	75-400	80		
Enclose – Type	Pitch	Bending Radius R	Weight	Speed	Temperature	Clearance				Frame style	Divider possible with frame
CPS036E.035	36	70,90,120,150	1.23	10	-30 ~ +130	59	38	35	27		
CPS036E.055	36		79			38	55	27			
CPS036E.075	36		99			38	75	27			
CPS036E.100	36		124			38	100	27			
CPS050E.050	50	100,125,150,200	2.07	10	-30 ~ +130	78	52	50	30.5		
CPS050E.075	50		103			52	75	30.5			
CPS050E.100	50		128			52	100	30.5			
CPS050E.150	50		178			52	150	30.5			

COMPANY Sabin Chain
 CPS CABLECHAIN
 Revolving Chain
 Helix Chain
 ROBO-KIT
 CPSFLEX
 CPSFIX

Using Material of High Quality

MINI Type

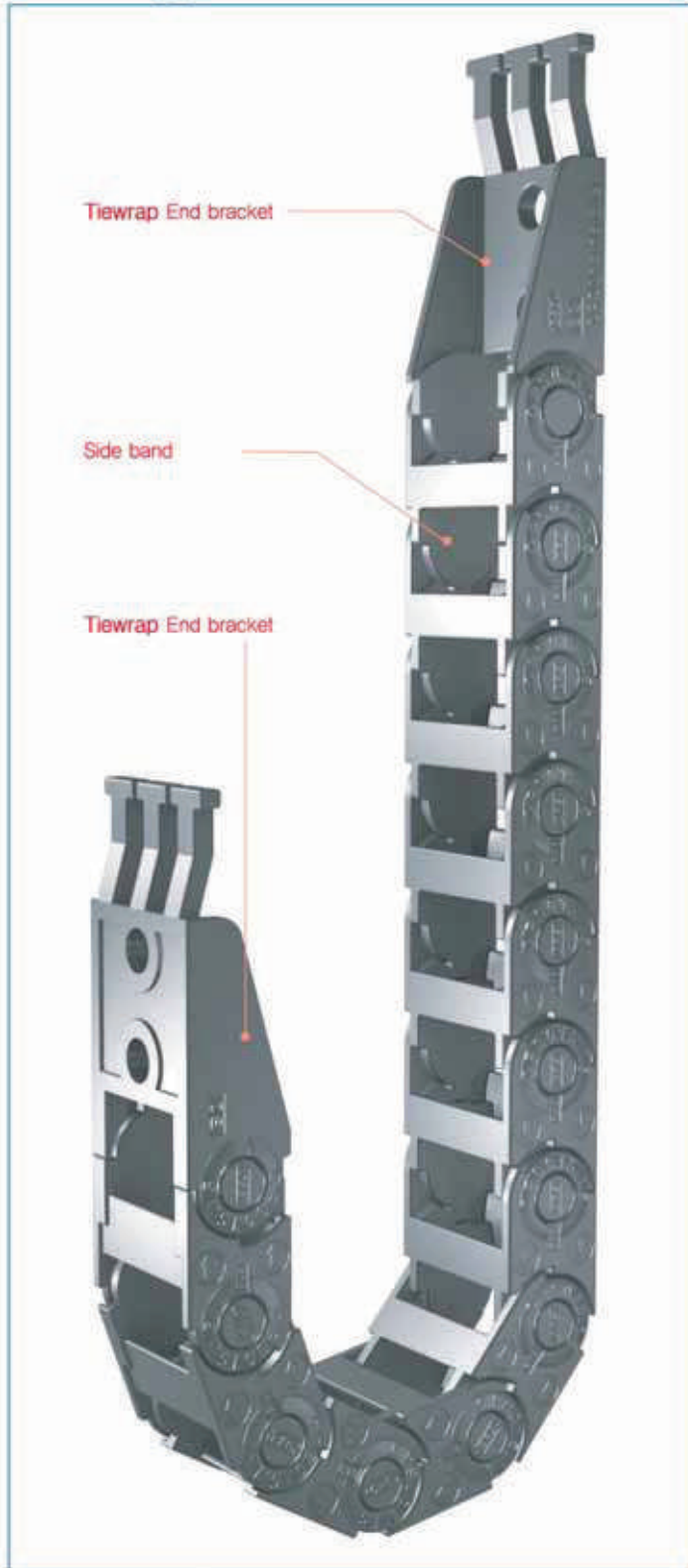

CPS 015 Type

1 Chain material

CPS—polyamide with glass fiber reinforced, UL94—HB

2 Low Noise : 40 dB (DIN EN 61672-1)

3 Speed : 10m/sec

4 Temperature : -30°C ~ +130°C

5 Other installation Length

Vertical curve above= max 0.8m

Vertical curve below= max 3.0m

Side Mounted, Unsupported= max 0.2m

6 Applications : Printing Machine, Feeder unit Count machine.

7 Load diagrams

self-supporting length

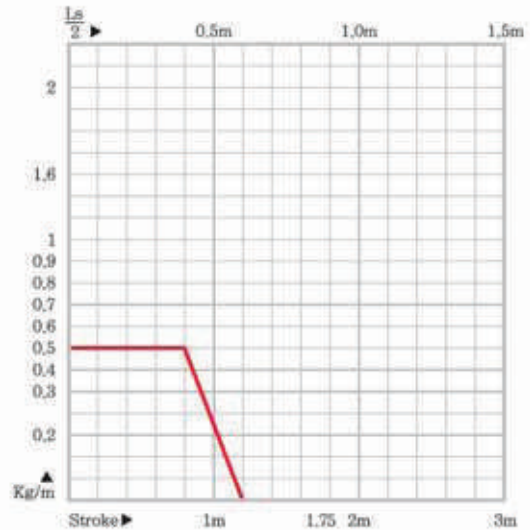

8 Calculation of the chain length

$$L = \frac{L_s}{2} + L_p$$

CPS 015

Using Material of High Quality

Layout of the CPS cable chain

- Ls : stroke
- Lp : loop length
- Lf : loop projection
- Hs : safe space

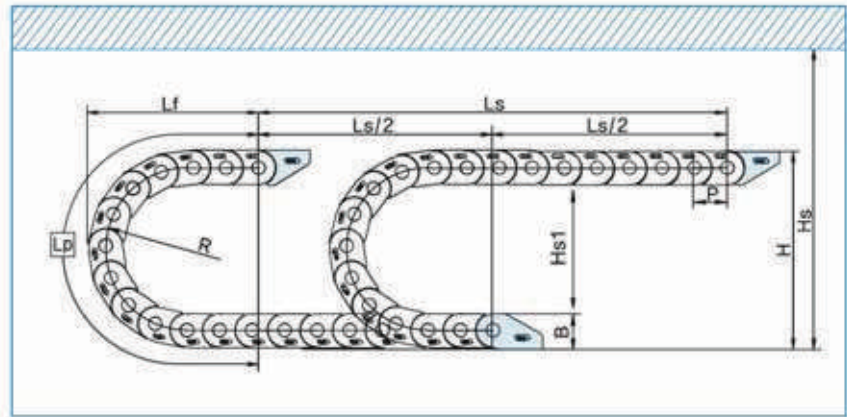

Type CPS015

Pitch P: 15mm
 Height B : 13mm
 Height H : 2R+B
 $H_s \geq H+10\text{mm}$
 $H_{s1} \leq -10\text{mm}$

(dimensions in mm)

Bending radius R	18	28	38
Lp	117	148	180
Lf	55	65	75
H	49	69	89

Ordering

CPS 015. 10. R28 / B₂ - 1,000L : 10ST

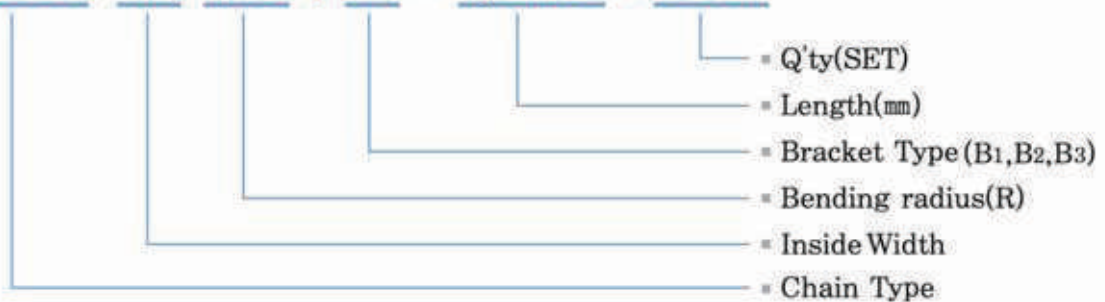

Bracket Type

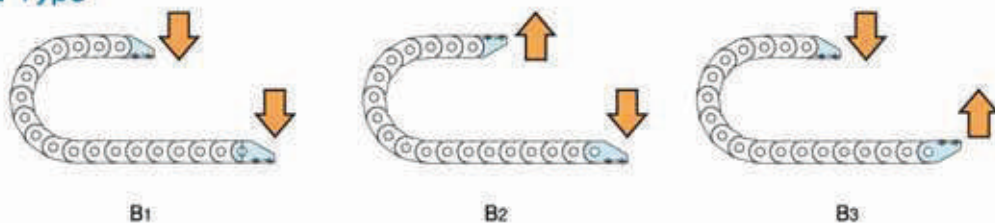

Using Material of High Quality

CPS 015

Chain cross section

• Type CPS 015.06

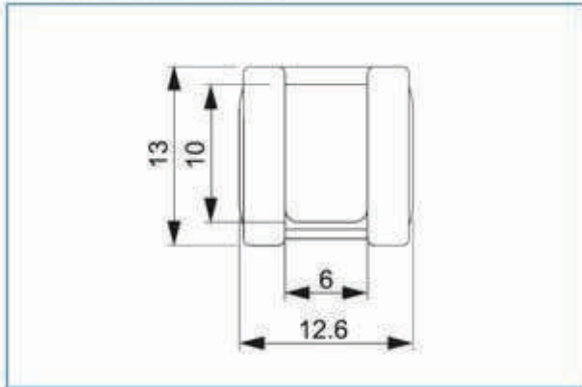

• Type CPS 015.10

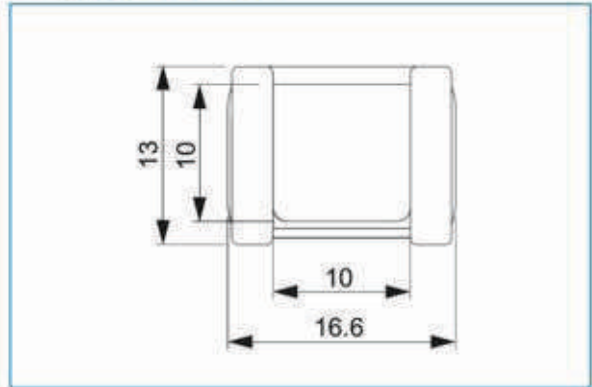

• Type CPS 015.15

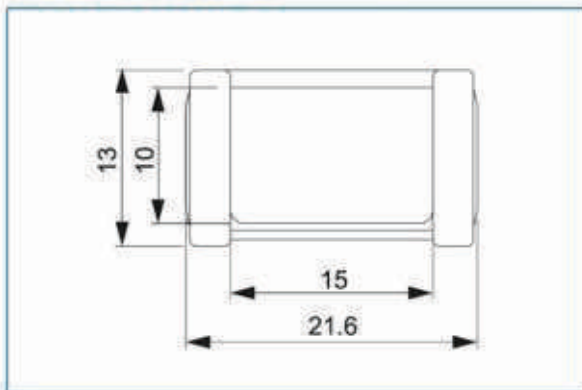

• Type CPS 015.20

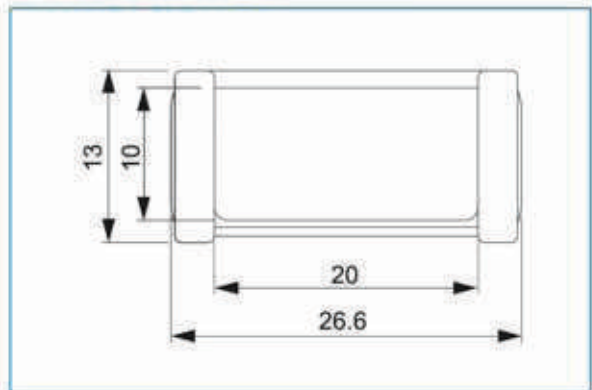

Chain Radius, Weight

Chain Type	Bending Radius(R)	Weight in kg/m
CPS 015.06	18, 28, 38	0.100
CPS 015.10		0.106
CPS 015.15		0.111
CPS 015.20		0.115

CPS 015

Using Material of High Quality

End Bracket (Tiewrap Type)

● CPS 015.06 Fixing point

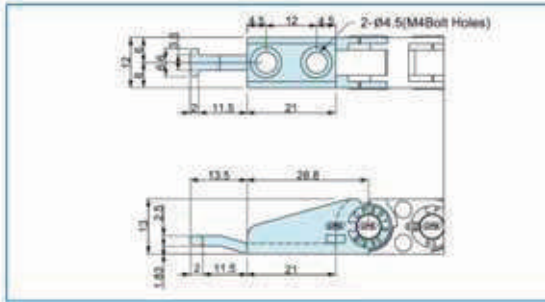

● CPS 015.06 Moving point

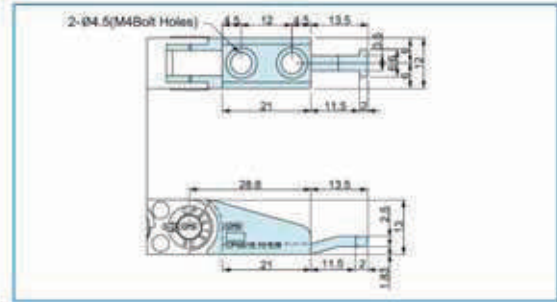

● CPS 015.10 Fixing point

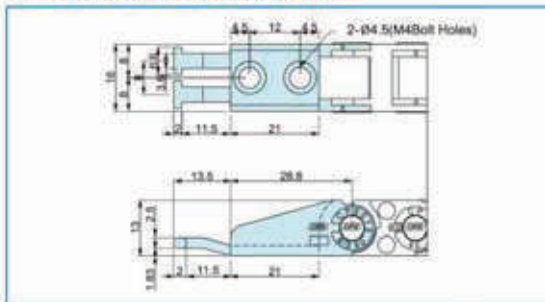

● CPS 015.10 Moving point

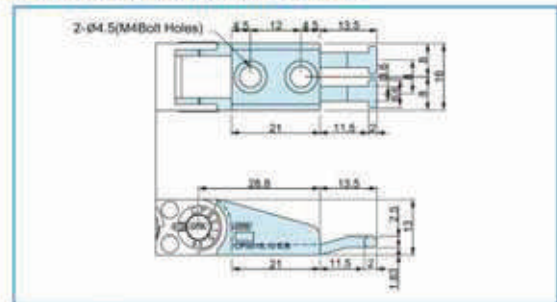

● CPS 015.15 Fixing point

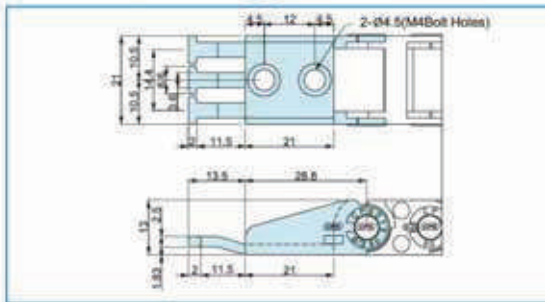

● CPS 015.15 Moving point

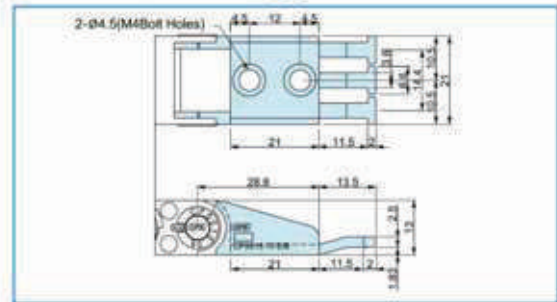

● CPS 015.20 Fixing point

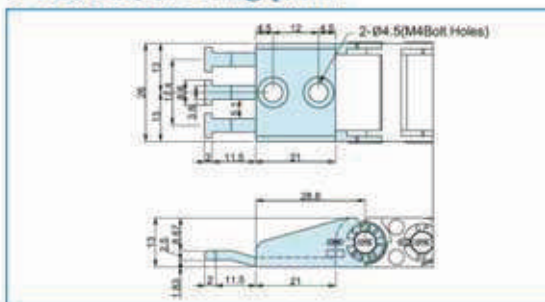

● CPS 015.20 Moving point

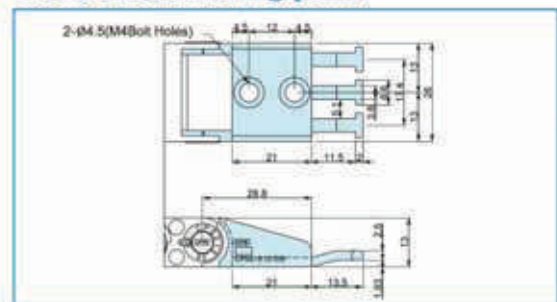

COMPANY Sabin Chain CPS CABLECHAIN Revolving Chain Helix Chain ROBO-KIT CPSFLEX CPSFIX

Using Material of High Quality

MINI Type



CPS 020 Type

1 Chain material

CPS-polyamide with glass fiber reinforced, UL94-HB

2 Low Noise : 40 dB (DIN EN 61672-1)

3 Speed : 10m/sec

4 Temperature : -30°C ~ +130°C

5 Other installation Length

Vertical curve above= max. 1.0m

Vertical curve below= max. 5.0m

Side Mounted, Unsupported= max. 0.5m

6 Applications : Printing Machine, Feeder unit Count machine.

7 Load diagrams self-supporting length

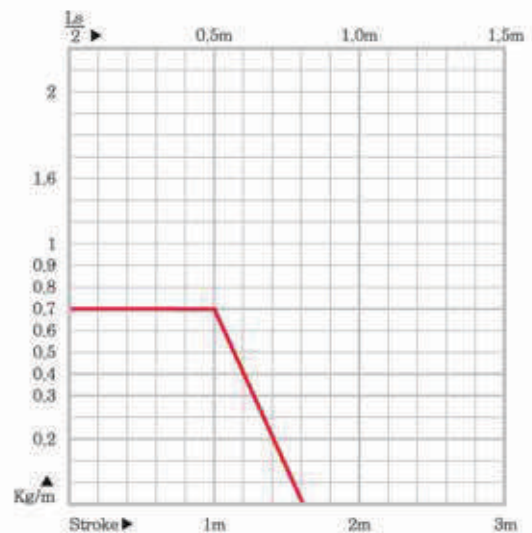

8 Calculation of the chain length

$$L = \frac{Ls}{2} + Lp$$

Using Material of High Quality

CPS 020

Layout of the CPS cable chain

- Ls : stroke
- Lp : loop length
- Lf : loop projection
- Hs : safe space

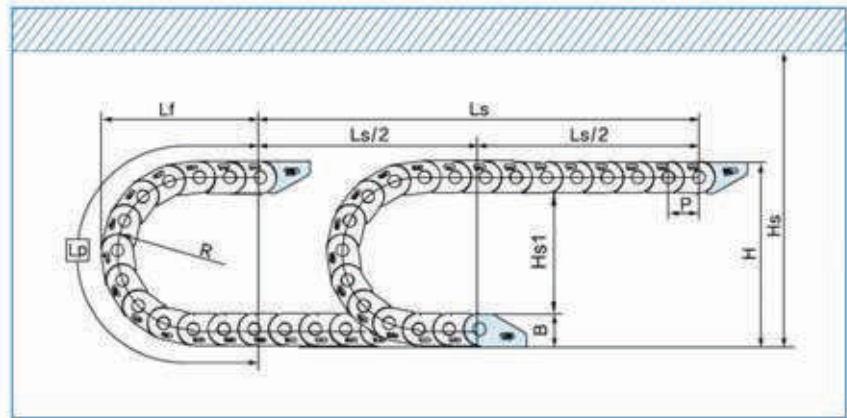

Type CPS020

Pitch P : 20mm
 Height B : 20mm
 Height H : 2R + B
 $Hs \geq H + 15mm$
 $Hs1 \leq -15mm$

(dimensions in mm)

Bending radius R	28	38	48
Lp	170	200	230
Lf	78	88	98
H	76	96	116

Ordering

CPS020. 30. R28 / B₂ - 1,000L : 10ST

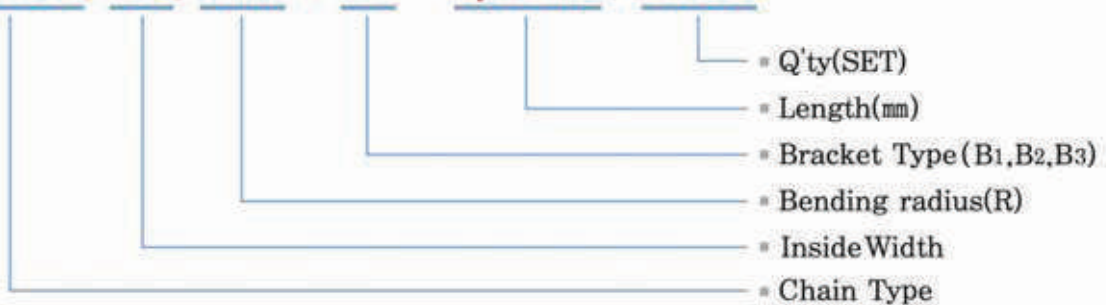

Bracket Type

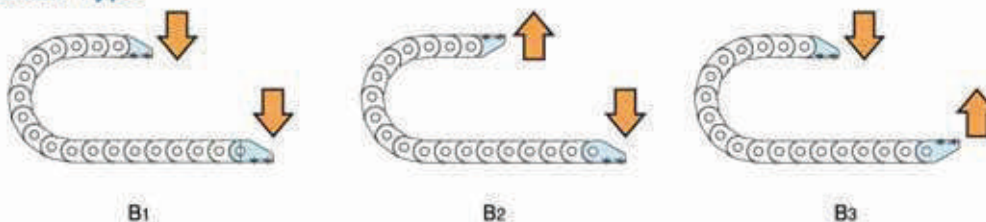

Using Material of High Quality

CPS 020

Chain cross section

• Type CPS020.15

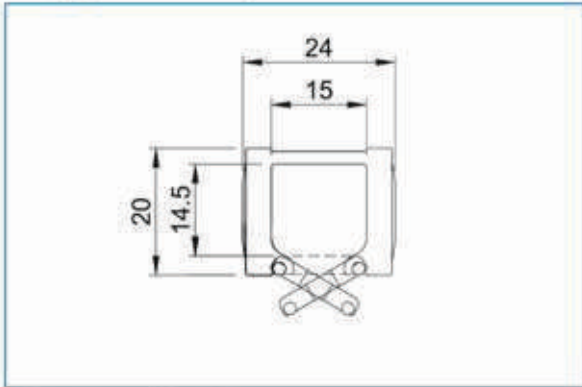

Down open hinge frame

• Type CPS 020.20

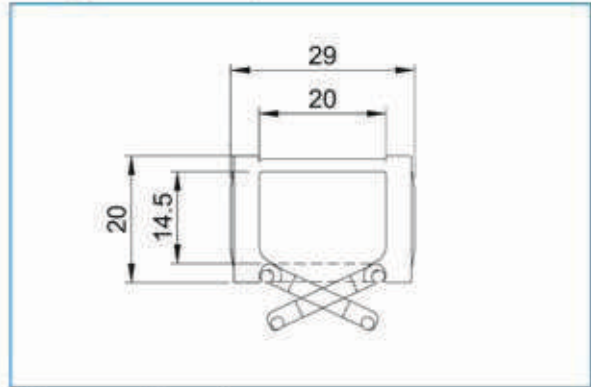

Down open hinge frame

• Type CPS020.30

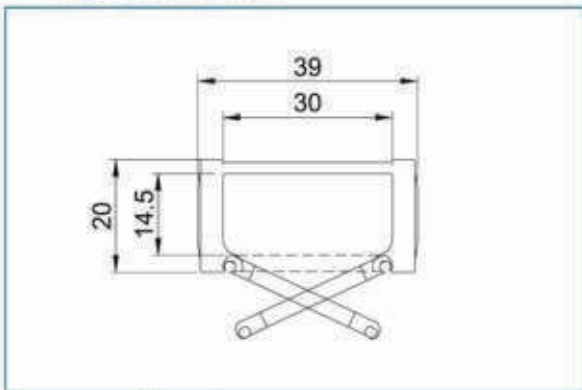

Down open hinge frame

• Type CPS 020.40

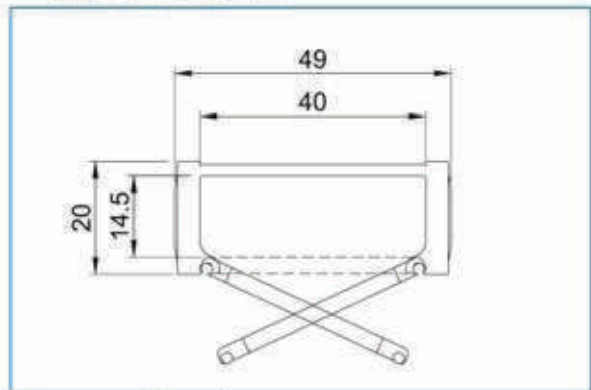

Down open hinge frame

Chain Radius, Weight

Chain Type	Bending Radius(R)	Weight in kg/m
CPS 020.15	28, 38, 48	0.245
CPS 020.20		0.260
CPS 020.30		0.285
CPS 020.40		0.310

Using Material of High Quality

CPS 020

End Bracket (Tiewrap Type)

● CPS 020.15 Fixing point

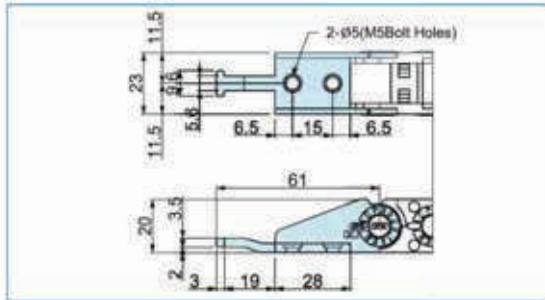

● CPS 020.15 Moving point

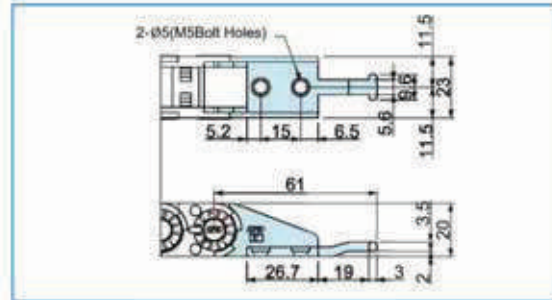

● CPS 020.20 Fixing point

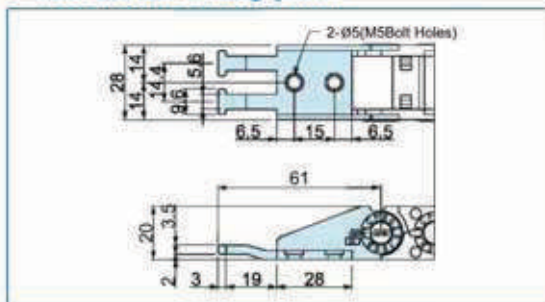

● CPS 020.20 Moving point

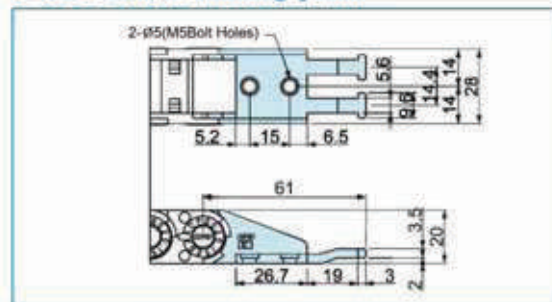

● CPS 020.30 Fixing point

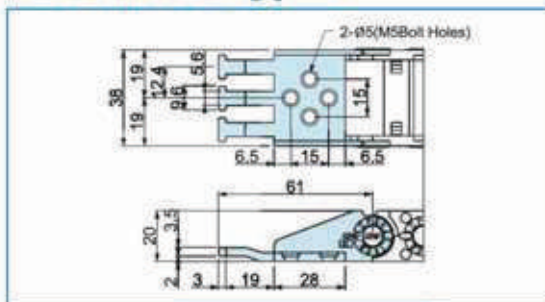

● CPS 020.30 Moving point

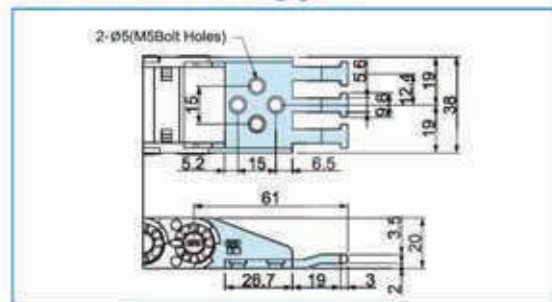

● CPS 020.40 Fixing point

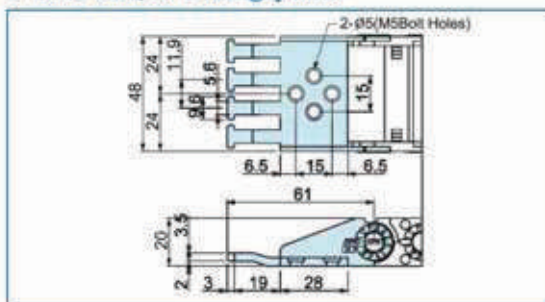

● CPS 020.40 Moving point

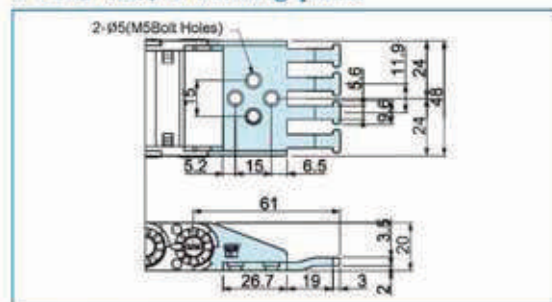

Using Material of High Quality

MINI Type

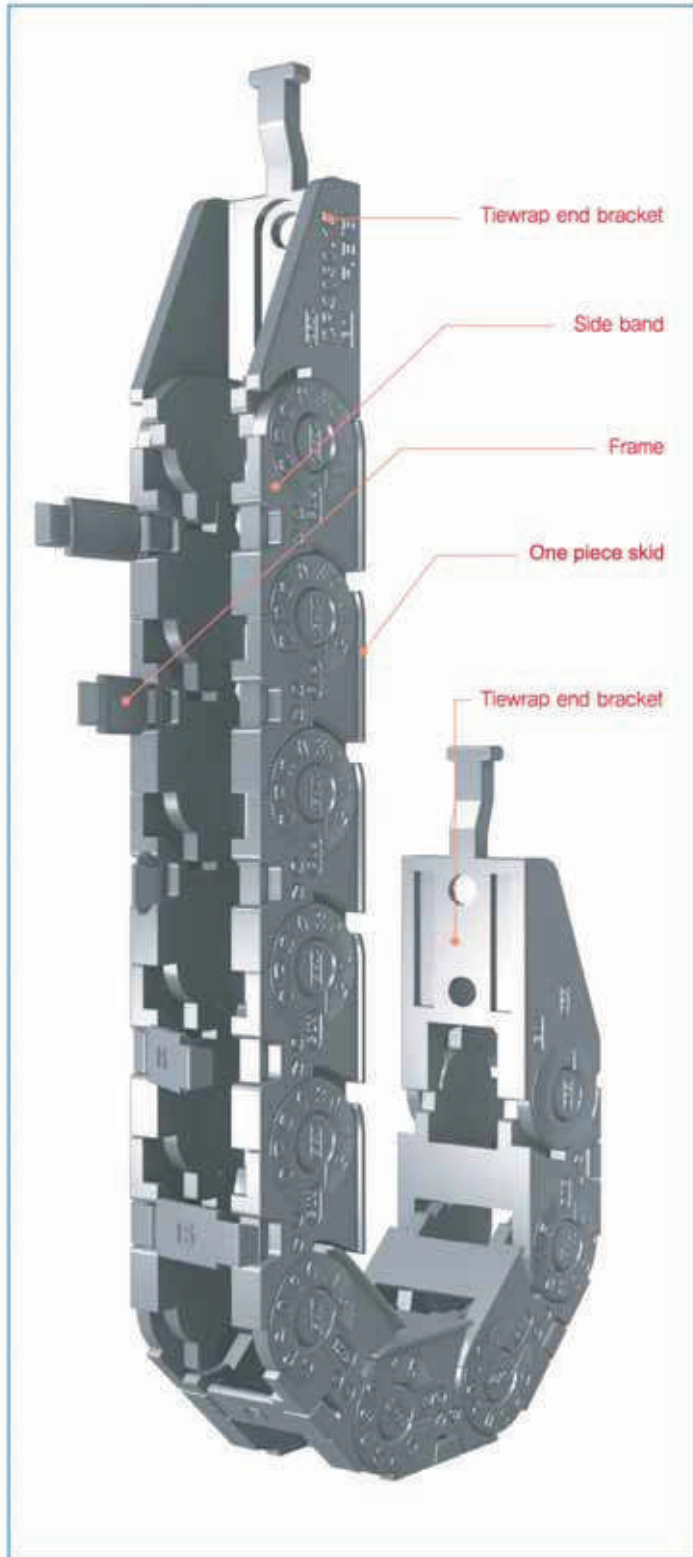

CPS 030 Type

1 Chain material

CPS—polyamide with glass fiber reinforced, UL94—HB

2 Low Noise : 40 dB (DIN EN 61672-1)

3 Speed : 10m/sec

4 Temperature : -30°C ~ +130°C

5 Other installation Length

Vertical curve above= max 1.5m

Vertical curve below= max 10m

Side Mounted, Unsupported= max 0.6m

6 Applications :

Gantry robot, Machining center,
Textile machine, Welding machine,
Feeder unit, Assembly loader,
Wood work machine, Fabric machine.

7 Load diagrams

self-supporting length

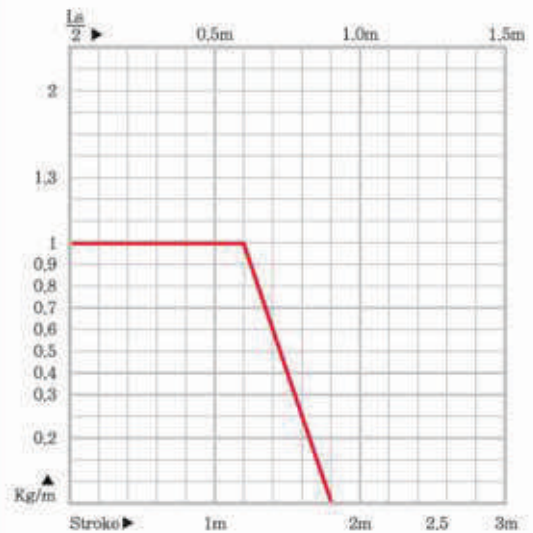

8 Calculation of the chain length

$$L = \frac{Ls}{2} + Lp$$

CPS 030

Using Material of High Quality

Layout of the CPS cable chain

- Ls : stroke
- Lp : loop length
- Lf : loop projection
- Hs : safe space

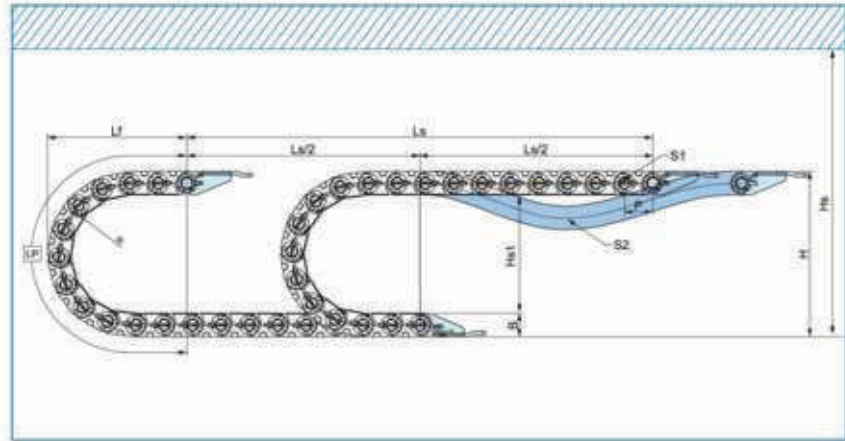

Type CPS 030

Pitch P : 30mm
 Height B : 26mm
 Height H : 2R+B
 Hs ≥ H+30mm
 Hs1 ≤ -30mm

(dimensions in mm)

Bending radius R	38	48	75	100
Lp	240	271	356	434
Lf	110	119	148	173
H	101	121	175	225

Ordering

CPS 030. 37. R75 / B₂ T - 900L : 10ST

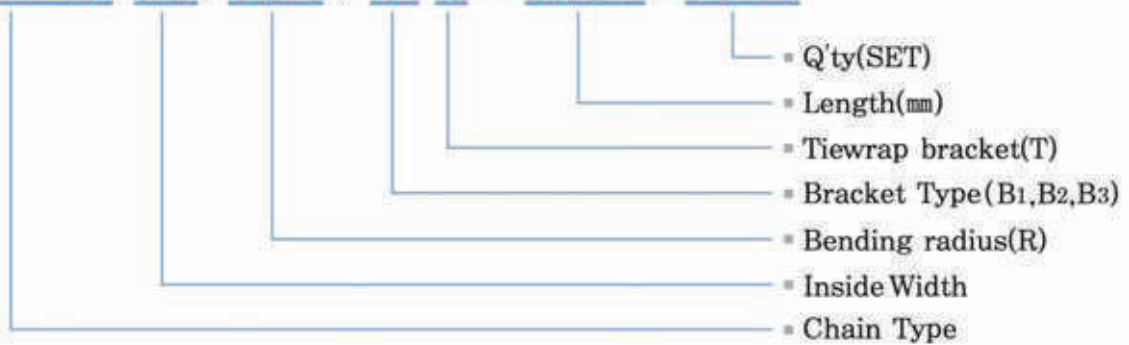

Bracket Type

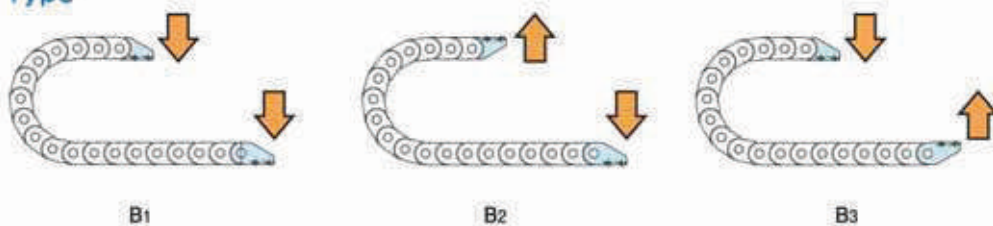

Using Material of High Quality

CPS 030

Chain cross section

• Type CPS030.15

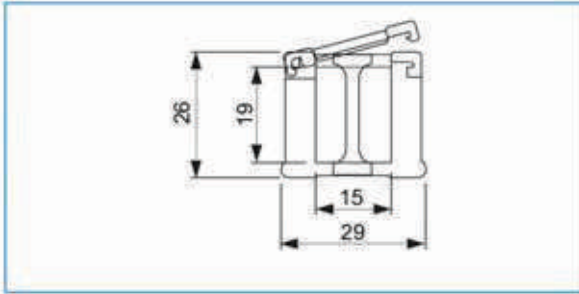

• Type CPS030.25

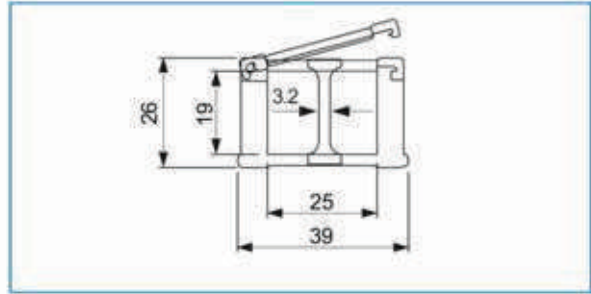

• Type CPS030.35

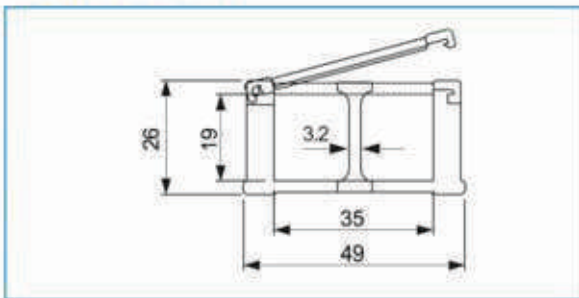

• Type CPS030.50

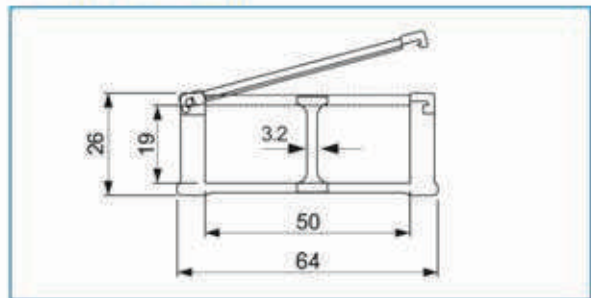

Chain Radius, Weight

Chain Type	Bending Radius(R)	Weight in kg/m
CPS 030.15	38, 48, 75, 100	0.38
CPS 030.25		0.40
CPS 030.35		0.42
CPS 030.50		0.44

Dividers & Separators

Installing dividers & separators enables cables to divide from each other and also prevent them tangling together.

체인내부에 디바이더와 세퍼레이터를 설치하여 입선되는 케이블을 서로 분리시키는 역할을 하며 케이블의 영입현상을 방지한다.

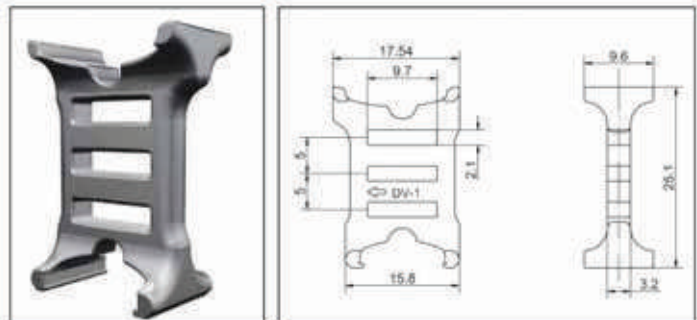

CPS 030

Using Material of High Quality

End Bracket (Tiewrap Type)

● CPS 030.15 Fixing point

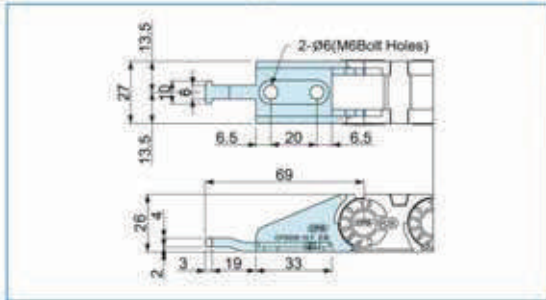

● CPS 030.15 Moving point

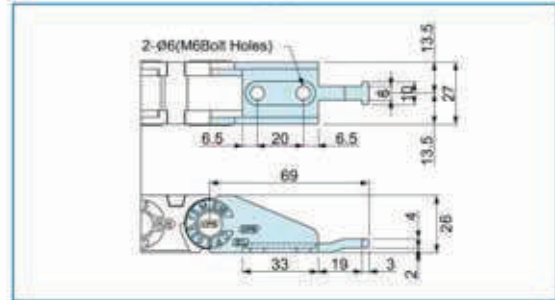

● CPS 030.25 Fixing point

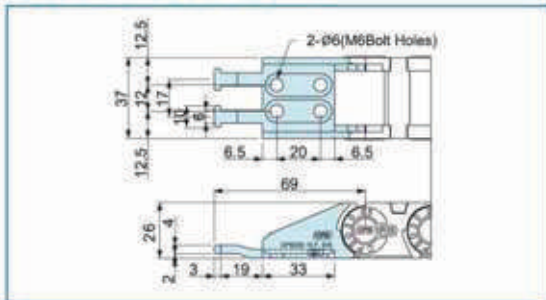

● CPS 030.25 Moving point

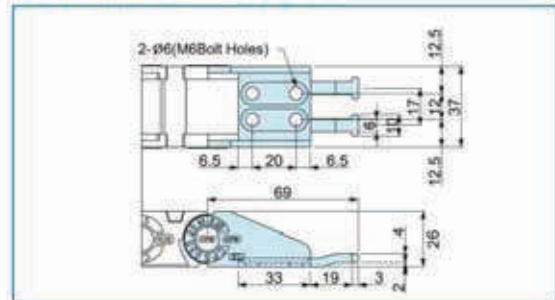

● CPS 030.35 Fixing point

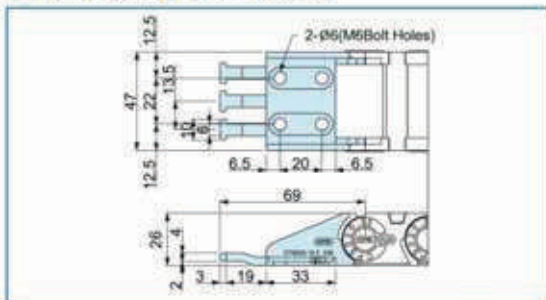

● CPS 030.35 Moving point

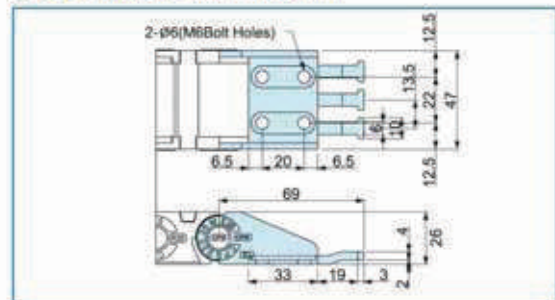

● CPS 030.50 Fixing point

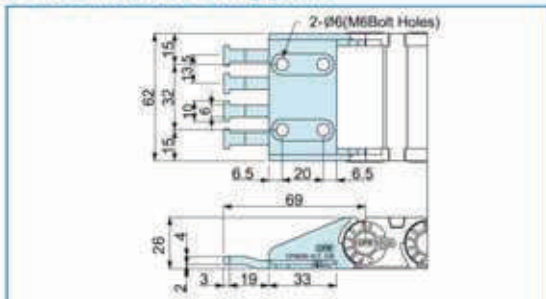

● CPS 030.50 Moving point

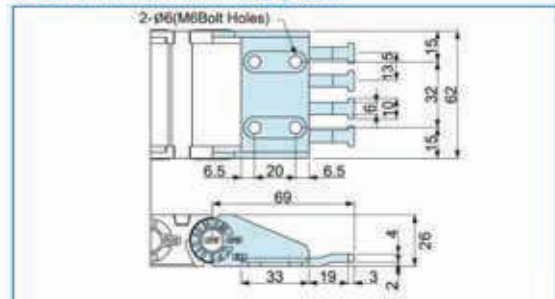

Using Material of High Quality

MINI Type

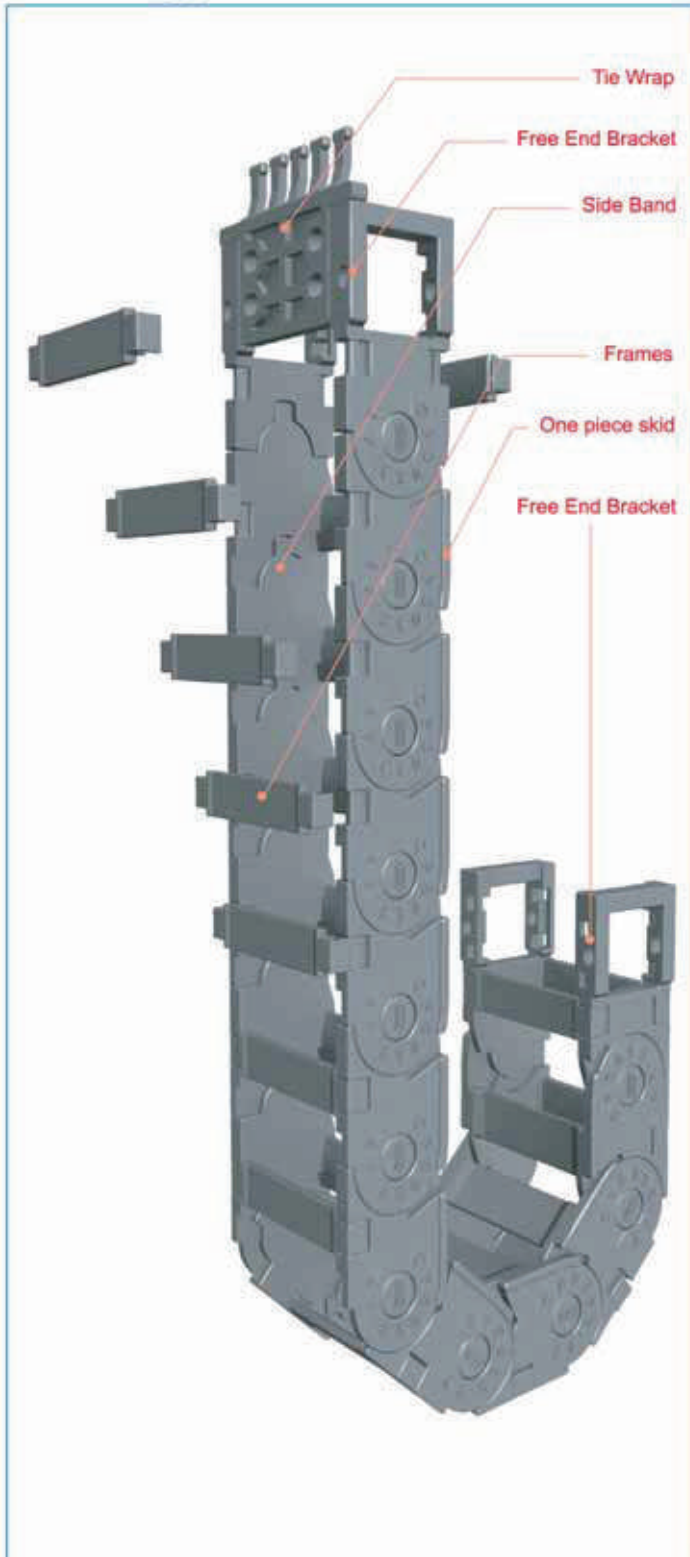

CPS 033 Type

1 Chain material

CPS-polyamide with glass fiber reinforced, UL94-HB

2 Low Noise : 40 dB (DIN EN 61672-1)

3 Speed : 10m/sec

4 Temperature : -30°C ~ +130°C

5 Other installation Length

Vertical curve above= max 1.5m

Vertical curve below= max 10m

Side Mounted, Unsupported= max 0.6m

6 Applications : Gantry robot, Machining center, Textile machine, Welding machine, Feeder unit, Assembly loader, Wood work machine, Fabric machine.

7 Load diagrams self-supporting length

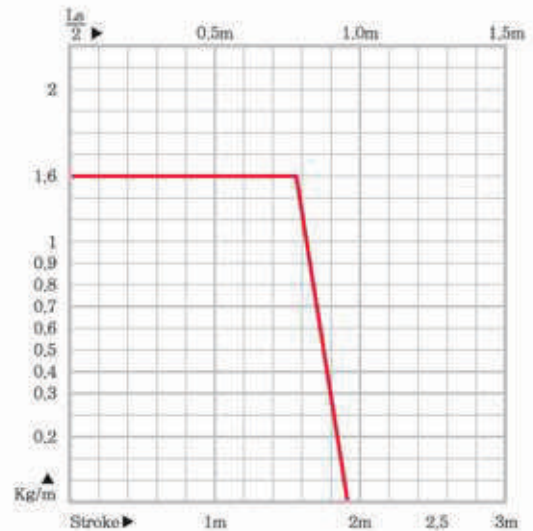

8 Calculation of the chain length

$$L = \frac{L_s}{2} + L_p$$

Using Material of High Quality

CPS 033

Layout of the CPS cable chain

- Ls : stroke
- Lp : loop length
- Lf : loop projection
- Hs : safe space

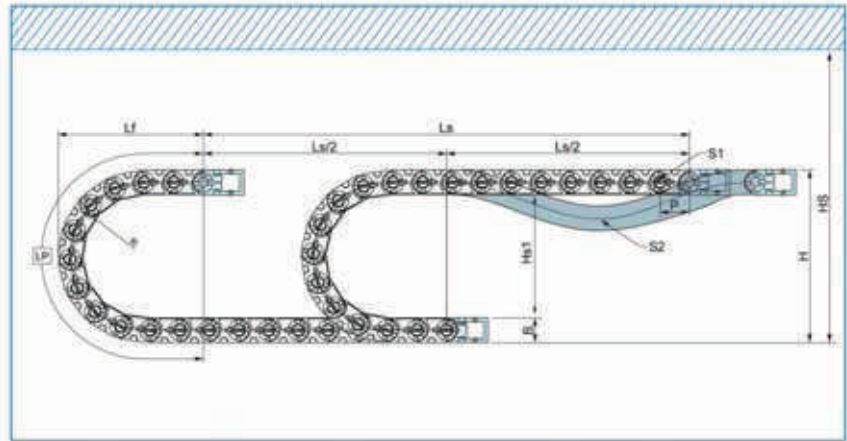

Type CPS 033

Pitch P : 33mm
 Height B : 31mm
 Height H : 2R+B
 $Hs \geq H+30mm$
 $Hs1 \leq -30mm$

(dimensions in mm)

Bending radius R	35	45	75	100	120
Lp	242	274	368	446	509
Lf	117	127	157	182	202
H	101	121	181	231	271

Ordering

CPS 033. 37. R75 / E - 900L : 10ST



Bracket Type

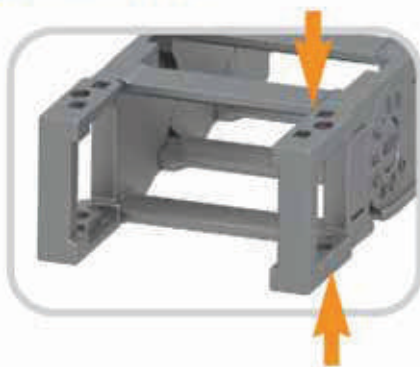

EEB (Easy End Bracket)



The fixing end part of cable chain which improve the efficiency of mounting condition by unify the exist easy end bracket and normal end bracket.

체인을 고정하는 끝부분으로 기존 Easy Bracket 과 Normal Bracket을 하나로 통합한 방식으로 취부의 효율성을 높임.

* Above products are patent registered item which can be protected by industrial property right. 상기제품은 특허등록 제품으로 산업재산권의 보호를 받는 제품입니다.

Using Material of High Quality

CPS 033

Chain cross section

● Type CPS 033.27

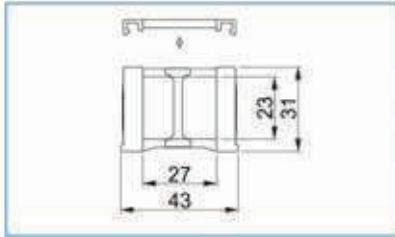

● Type CPS 033.37



● Type CPS 033.47

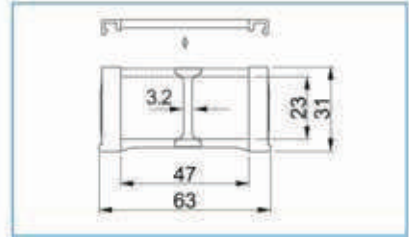

● Type CPS 033.67

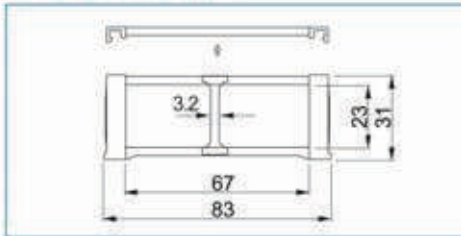

● Type CPS 033.77

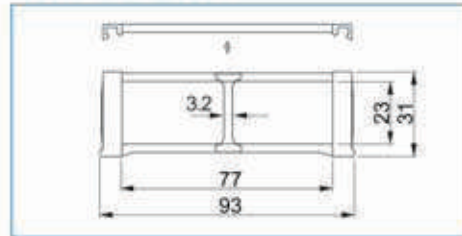

End Bracket - Easy Type

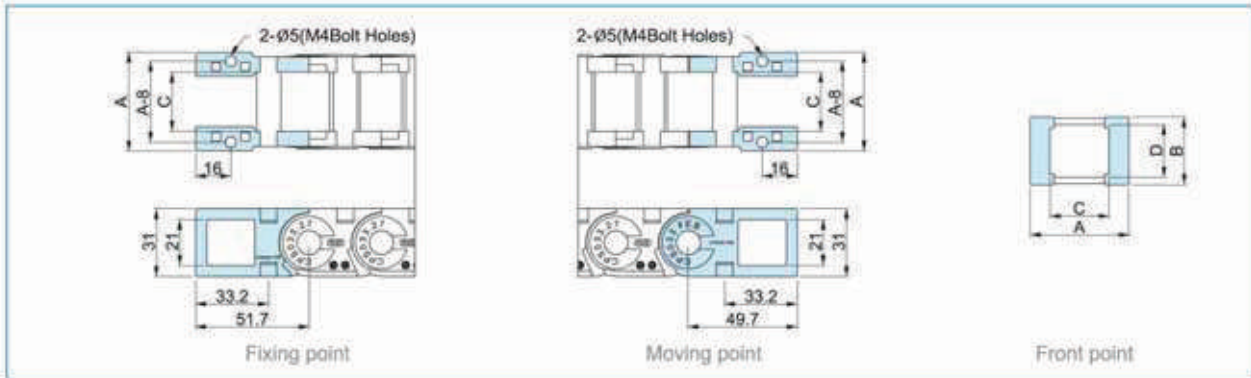

Chain Type	A	B	C	D	Hole Type
CPS033.27	45	31	27	23	M4 Holes
CPS033.37	55		37		
CPS033.47	65		47		
CPS033.67	85		67		
CPS033.77	95		77		

Using Material of High Quality

CPS 033

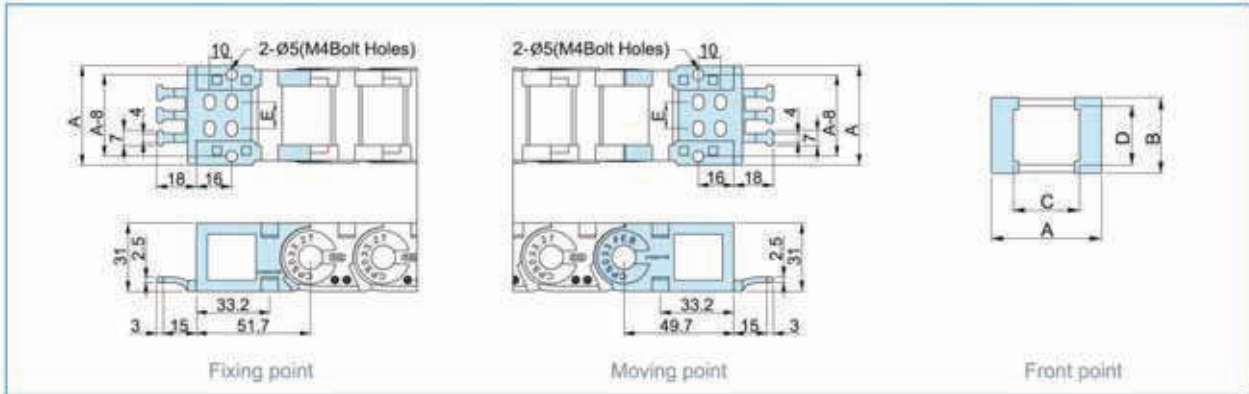
End Bracket -Free End Bracket (Tie wrap connection)

Chain Type	A	B	C	D	E	Hole Type
CPS033.27	45	31	27	23	12	M4 Holes
CPS033.37	55		37		22	
CPS033.47	65		47		32	
CPS033.67	85		67		52	
CPS033.77	95		77		62	

Tie Wrap

Tie wrap prevents cut off problem of the cable by the twisting and pulling movement.
 Tiewrap은 케이블체인의 브라켓을 기준으로 설치함으로써 체인의 움직임으로 인해 체인내의 케이블이 나 호스가 당겨져 단선되는 경우를 방지할 수 있다.

The tie wrap of this Sabin Chain has two types, separated with bracket type and attached with bracket type.
 Sabin Chain의 Tiewrap은 브라켓부분과 근접해서 사용할 수 있는 사양 과 브라켓에 결합해서 사용할 수 있는 사양 으로 구분되어 사용할 수 있다.

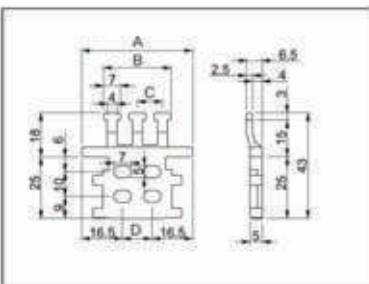

	27	37	47	67	77
A	45.0	55.0	65.0	85	95
B	27.5	41.0	47.9	67.9	77.9
C	10.2	8.5	10.4	10	8.8
D	12.0	22.0	32.0	52	62